

THERMAL PRINTER

model

Smart / Witty 2000k

OPERATIVE MANUAL



Italora S.p.A. Largo Guastalla 7 - 20082 Binasco - (Milano)
Tel: ++39.02.90092074 - Fax: ++39.02.9055461

web: <http://www.italora.it/>
e-mail: <mailto:sales@italora.it>

GENERAL INDEX

PICTURES INDEX	4
CH. 1 – TECHNICAL DATA	5
Technical Specifications	5
1.3 Frontal and rear sight	6
1.4 Side sight.....	7
1.5 Incoming inspection.....	7
1.6 Start up with pushed PRINT button	8
1.7 Printing media description	8
1.8 Labels replacement	8
1.8.1 Label roll replacement	8
1.8.2 Dispensing mode.....	8
1.8.3 Strip form mode.....	9
1.8.4 Rewinding mode.....	9
1.9 Serial Interface	10
1.9.1 Connecting printer to 9 pins PC serial port.....	10
1.9.2 Connecting printer to 25 pins PC serial port.....	10
CH. 2: STANDARD PROGRAMMING MODE	11
2.1 F1 key: Programmed Data Storing	12
2.2 F2 key: settings of Euro change and active PLU number.....	12
2.3 F3 key: PLU (merceologic) mode	13
2.4 F4 key: Internal clock setting (Date and Hour)	13
2.5 F5 key: automatic conversion NATIONAL MONEY→EURO (€).....	14
2.6 F6 key: Remote Terminal mode	15
2.7 MENU key: general working parameters	16
2.7.1 Serial port Baud Rate	17
2.7.2 Serial port Parity	17
2.7.3 Serial port DATA Bit	17
2.7.4 Serial port STOP Bit.....	18
2.7.5 Media type	18
2.7.6 Label taken photosensor	19
2.7.7 Preprinted labels	19
2.7.8 Label alignment: Y Gap.....	20
2.7.9 Voltage drop Monitoring	21
2.7.10 Macro-Interpreter Mode.....	22
2.7.11 National characters set.....	22
2.7.12 Serial RTS control line level	23
2.7.13 Input 'Pick & Place' signal	23
2.7.14 End of Print signal	24
2.8 Printinting Intensity modifying.....	25
2.8.1 Manual modifying (UP / DOWN arrow keys)	25
2.8.2 Software Modifying.....	25
2.9 Security Password modifying (SHIFT + MENU keys).....	26
2.10 Memory RESET (BKSP + ENTER keys)	27
2.11 Displaying printed meters (ENTER + DOWN ARROW keys)	28
CH. 3: "PLU" MODE.....	29
3.1 Four PLU types description	29
3.1.1 STAND ALONE PLU	30
3.1.2 STANDARD WEIGHT PLU	30
3.1.3 SLAVE WEIGHT PLU	31
3.1.4 BCD WEIGHT PLU	31
3.2 Label layouts for "Products" (PLU)	32
3.2.1 Fixed Tests.....	32
3.2.2 Variable texts.....	32
3.2.3 Ingredients list	33

3.3	Label layouts for “Partial” and “General” Totals	33
3.4	Label layouts for “Grand Total”	33
3.5	Keys and functions in PLU mode.....	34
3.6	PLU operations.....	36
3.6.1	Swap Manual / Automatic mode (SHIFT key)	36
3.6.2	PLU selection	36
3.6.3	Printing of a “Stand Alone” PLU (ENTER key)	37
3.6.4	Change of 5 product names (F1 key)	37
3.6.5	Change of Unit Price (F2 key)	38
3.6.6	Change of Dates: Packing, Seasoning and Best Before (F3 key).....	38
3.6.7	PLU Variable fields setting (F4 key)	41
3.6.8	Barcode settings.....	42
3.6.9	Adding new texts into Database	44
3.6.10	Ingredient field modifying	45
3.6.11	Copying an existing PLU into a new one (F5 key).....	46
3.7	Totals management.....	47
3.7.1	Partial Total	47
3.7.2	General Total.....	47
3.7.3	Grand Total	47
3.7.4	Manual Totals erasing (F6 key)	48
3.7.5	Printing of Total labels (F6 key).....	48
3.7.6	Settings of Grand Total label parameters.....	49
3.8	Changing label Layout (BKSP + UP / DOWN keys).....	52
3.8	PLU Options: MENU key	53
3.8.1	Decimal digits of Net Weight into product labels (only BCD).....	53
3.8.2	Decimal digits of Tare into product labels (only BCD)	53
3.8.3	Decimal digits of Price/Amount into product labels (only BCD).....	54
3.8.4	Decimal digits of Net Weight into total labels	54
3.8.5	Type of input serial record.....	54
3.8.6	Length or Terminator Character of incoming serial record	55
3.8.7	Full Serial Protected Protocol.....	55
3.8.8	Manual setting of Incremental Counter.....	56
3.8.9	Printing Lot settings: upper number of printable labels	56
3.8.10	Printing Lot settings: ON / OFF	56
3.8.11	Printing of Partial Total when end of lot is reached: ON / OFF	57
CH. 4:	ETIK PROGRAM BASIC SETTINGS	58
4.1	Selection of archive file.....	58
4.2	Scale parameters programming window	59
4.3	Creating an Ingredients database.....	62
4.4	Creating a Products database (PLU table)	63
CH. 5:	STORING DATA INTO PRINTER	65
5.1	Verifying printer–PC serial connection.....	65
5.2	Using an internal PLU label	66
5.3	Transmission and storing of data to printer	66
CH. 6:	MAINTENANCE	67
6.1	Printhead cleaning.....	67
6.2	Cleaning of Rubber feeding roll	67
6.3	Cleaning of photosensors.....	67
6.4	Cleaning of Metallic and plastic parts	67
6.5	Cleaning of adhesive traces or parts of labels.....	67
CH. 7:	FREQUENTLY ASKED PROBLEMS	68
7.1	There’s no labels feeding	68
7.2	Wrong label alignment.....	68
7.3	Paper slides to right side	68
7.4	Printing defects.....	68

7.5	Blanks label emitted	68
7.6	Printing trimmer not correct	68
7.7	Labels are not peeled off	69

PICTURES INDEX

Pic. 1	Frontal Sight.....	6
Pic. 2	Rear Sight	6
Pic. 3	Side sight	7
Pic. 4	Option to rewind printed labels.....	9
Pic. 5	Serial connector	10
Pic. 6	ETIK: Archive selection	58
Pic. 7	ETIK: Scale programming window	59
Pic. 8	ETIK: Ingredients Database	62
Pic. 9	ETIK: PLU table	63
Pic. 10	ETIK: Verifying serial connection	65

CH. 1 – TECHNICAL DATA

These units offer a high quality printing with the possibility to store up to 26 label layouts into internal permanent memory. Printers can work in dispensing mode, in strip form mode or in rewinding mode.

Resident barcodes can be printed at high speed and eleven character fonts, expansible up to 8 times, cover a wide range of applications.

The inside label unwind holder offers an autonomy of 1750 labels (54 x 40 mm), the modular design of these printers offers an easy service as well for electronic boards as for mechanics maintenance.

TECHNICAL SPECIFICATIONS

Le stampanti di questa famiglia hanno ottenuto l'approvazione IMQ in accordo con la normativa europea EN 60950.

Printing Method:	Direct Thermal	Olaf	(fixed matrix)	32x48
Resolution:	8 dots/mm, 484 dots/line	New Century	(proportional)	45
Printing Width:	55 mm	Title	(fixed matrix)	88x88
Printing Speed:	up to 150 mm/s	Compact	(proportional)	19
Display:	Backlite LCD – 2 x 16 characters	Century	(proportional)	31
Keyboard:	24 keys (function + alphanumeric)	Arial	(proportional)	49
X/Y positioning of texts and bar codes		Bookman	(proportional)	63
Texts and bar codes printed in four orthogonal directions		Magnifications:	up to 8 (independently base and height)	
Lines, boxes, shadow and reverse printing		Characters Sizes:	0.62 x 0.66 mm minimum	
Graphic and logos:	bit image mode		99.00 x 105.30 mm maximum	
Bar Codes:	EAN8, EAN13, 2/5, 2/5 I, 3/9, 2/7, DUN-14/16, UPC-A, UPC-B, UPC-E, CODE 128, EAN 128	Microcontroller:	32 bit RISC	
Automatic Check Digit computation		Permanent Memory:	1 MB flash memory	
Wide/narrow ratio full programmable		Detectors:	End of paper and feeding synchronism	
Half, standard and double density		Print Media:	Labels, tags and continuous paper	
Height programmable		Label Sizes:		
Suppression of human readable characters		Width:	32 mm min., 62 mm max	
Batch printing:	up to 99.999.999 labels	Length:	6 mm min.	
Layouts:	26 programmable in internal FLASH		453 mm max	
Features:		Key: width:	2 mm min.	
Up to 10 protection levels for variable data printing		depth:	7 mm min. starting from inner edge	
4 up/down 16 digits alphanumeric counters		Roll Sizes:		
Real Time Clock		Width:	32 mm min., 62 mm max	
Black intensity adjustable via software		Outer Diameter:	130 mm max	
Print button for last label repeating		Core Diameter:	38 mm min.	
Thermal head temperature automatic control		Printer Dimensions:		
Data transfer interface		Height:	170 mm	
RS232 serial parameters:	Software programmable	Depth:	380 mm	
	Programmable by keyboard	Length:	178 mm	
Hand Shake Protocol:	SW – XON / XOFF	Weight:	10 Kg	
	HW – CTS / DTR	Power Requirements:		
Data Transmission:	ASCII format	Voltage:	220/240 Vac; 50-60 Hz	
Character Fonts:		on request:	110 Vac	
Standard	(fixed matrix) 7x5	Environment:		
Micro	(fixed matrix) 5x5	Operating temperature:	0°/ 40° C	
Big	(proportional) 32	Storage temperature:	-20°/60° C	
Draft	(fixed matrix) 8x13	Humidity:	10% - 95% non-condensing	
		Options:		
		Label taken sensor		
		Rewind unit		

1.3 FRONTAL AND REAR SIGHT

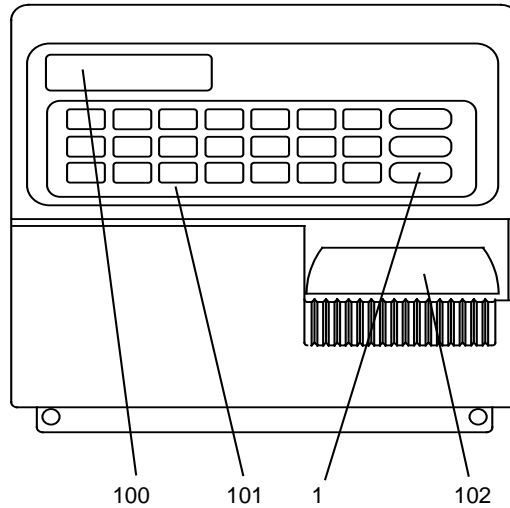

Pic. 1 Frontal Sight

- 1: Printing button
- 100: Display
- 101: Keyboard
- 102: Label output

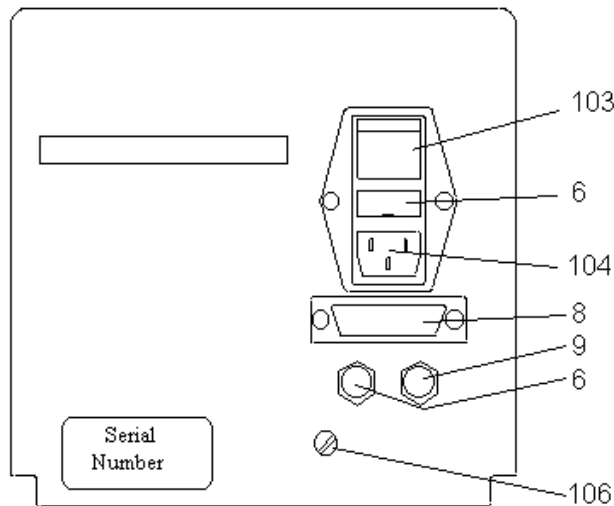

Pic. 2 Rear Sight

- 6: 1 fuse 1.6AT (logic)
- 6: 2 fuses 1.6AT (main)
- 8: RS232 serial connector
- 9: fuse 8AT (thermal head)
- 103: main switch
- 104: power cord plug

1.4 SIDE SIGHT

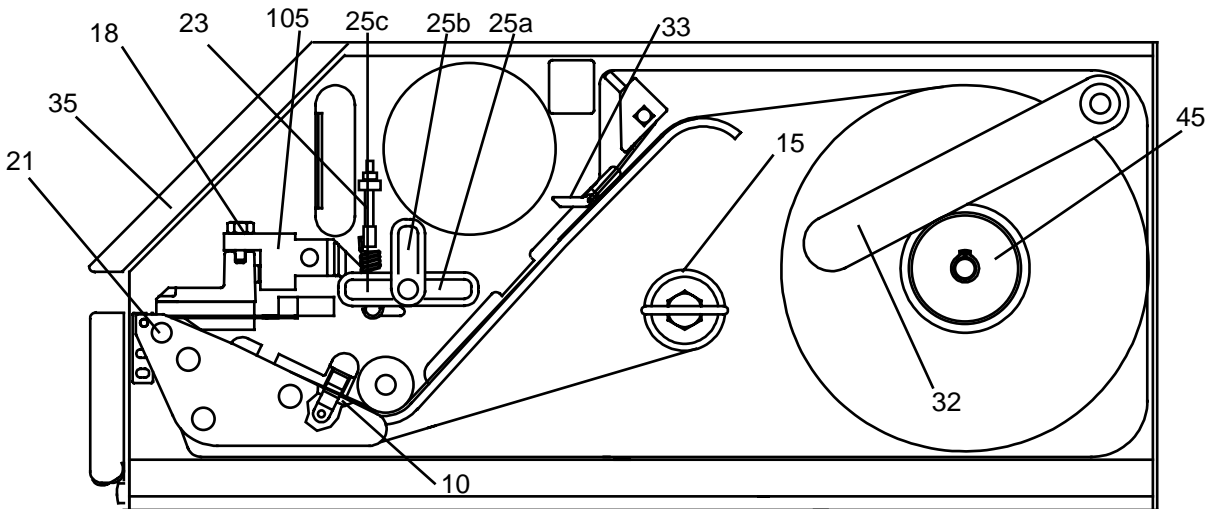

Pic. 3 Side sight

10	End of paper and label synchronisation photosensor	25b	Rest position
15	Rewinding shaft with adjusting clutch	25c	Cleaning position
18	Print head position fine adjustment	32	Label guide arm
21	Rubber feeding roll	33	Pressure clip
23	Print head assembly pressure spring	35	Front panel
25	Print head lock/unlock lever	45	Label unwind holder
25a	Working position	105	Print head assembly

1.5 INCOMING INSPECTION

- Open the main compartment
- Check the presence of the label roll
- Check the correct pinout of the serial I/O Cannon 25 pins female connector and connect the printer to the computer
- For further details see chapter “Connection to Host Computer”
- Check the voltage on the name plate next to the power receptacle
- Connect the power cable to a grounded power line
- Lift the printhead down by rotating the lever #25a
- Switch on the main switch on rear panel
- Display shows the message “Witty 2000 K / Ready”.
- Push the PRINT button, you will get a printing test with the firmware release information and further operating values
- Sending data from PC you will get a label printed
- Push the PRINT button to get the last label printed again; the printer keeps in memory the last label printed until next data arrive

NOTE: Printer retains the label length and the backing paper transparency in permanent memory.

In case of change of printing media see the following paragraph.

1.6 START UP WITH PUSHED PRINT BUTTON

The next procedure must be done each time you change printing media type.

- 1 Switch the printer off
- 2 Lift up the printing head by rotating lever #25b
- 3 Put the new label strip following Figure 3 indication
- 4 **(This point is necessary only for pre-printed labels)** Put manually the whitest part of label under paper photosensor #10
- 5 Check paper has been correctly positioned under the label photosensor #10
- 6 Lift down the printing head by rotating the lever #25a
- 7 Push PRINT button and turn on printer by keeping button pressed
- 8 Keep button pressed until two white labels have been completely put out
- 9 Release PRINT button when you see a label has been printed

1.7 PRINTING MEDIA DESCRIPTION

Paper specifications

White coated glossy printing paper

- weight: 65 ÷ 90 g/mq (ISO536)
- thickness: 0,075 ÷ 0,083 mm (ISO534)

Adhesive specifications

- peel adhesion(90° C): 430 N/m
- service temperature: -20° C ÷ + 70° C

Liner specifications

- BG 40 brown, supercalendered glassine
- weight: 65g/mq (ISO536)
- thickness: 0.057 mm (ISO534)
- transparency: 45%

Tags and continuous strip

- weight: 200 g/mq max

Labels and tags Dimensions

See paragraph 1.1

1.8 LABELS REPLACEMENT

1.8.1 LABEL ROLL REPLACEMENT

In case of changing of label format or printing media type, remember to follow the “Start up with pushed PRINT button” listed at paragraph #1.6

1.8.2 DISPENSING MODE

- Open side of printer
- Remove the empty label roll
- Lift up the guide arm #32
- Insert new label roll onto roller #45
- Bring the guide arm #32 down and push it tightly against the side of the label roll
- By rotating the lever #25b, lift the printing head #105 from the feed roller #21, setting the movement of labels and ribbon free
- Remove fork from shaft #15.
- Remove silicon support from rewinding shaft
- Remove the first labels from new roll, keeping free about 50 cm of silicon support
- Keep pressure clip #33 lifted up and slide silicon support to rewinding shaft #15
- Roll silicon support around shaft #15 and fasten it with the fork
- Turn the rewinder to stretch the paper
- Turn print head lever back to closed position #25a
- Check paper has been rightly positioned under the label photosensor #10
- Check pressure clip #33 has been positioned between centre and outer right side of the label
- Close side of printer

1.8.3 STRIP FORM MODE

- Open side of printer
- Remove the empty label roll
- Lift up the guide arm #32
- Insert new label roll onto roller #45
- Bring the guide arm #32 down and push it tightly against the side of the label roll
- By rotating the lever #25b, lift the printing head #105 from the feed roller #21, setting the movement of labels and ribbon free
- Keep pressure clip #33 lifted up and slide paper (or labels) following path between the feed roller #21 and the printing head #105
- Turn print head lever back to closed position #25a.
- Check paper has been rightly positioned under the label photosensor #10
- Check pressure clip #33 has been positioned between centre and outer right side of the label
- Close side of printer

1.8.4 REWINDING MODE

To rewind completely the printed labels the option P/N 80.162.0098 is necessary (see picture 4)

- 1 Open side of printer
- 2 Remove the empty label roll
- 3 Lift up the guide arm #32
- 4 Insert new label roll onto roller #45
- 5 Bring the guide arm #32 down and push it tightly against the side of the label roll
- 6 By rotating the lever #25b, lift the printing head #105 from the feed roller #21, setting the movement of labels and ribbon free
- 7 Keep pressure clip #33 lifted up and slide paper (or labels) following path between feed roller #21 and printing head #105. Put paper out of the printing head at least 50 cm
- 8 Roll the first part of strip of paper around shaft #15 and fasten it with the fork
- 9 Turn the rewriter to stretch the paper
- 10 Turn print head lever back to closed position #25a
- 11 Check paper has been rightly positioned under the label photosensor #10
- 12 Check pressure clip #33 has been positioned between centre and outer right side of the label
- 13 Close side of printer

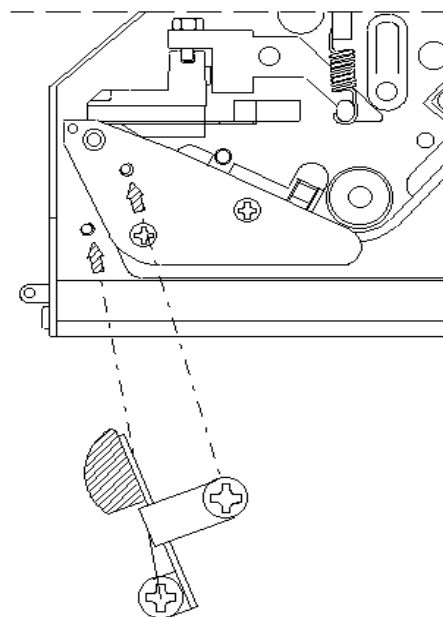

Pic. 4 Option to rewind printed labels

1.9 SERIAL INTERFACE

Witty 2000k printers have available serial interface type RS 232. The connector, type 25 pins DB female Cannon, is connected as shown into next picture.

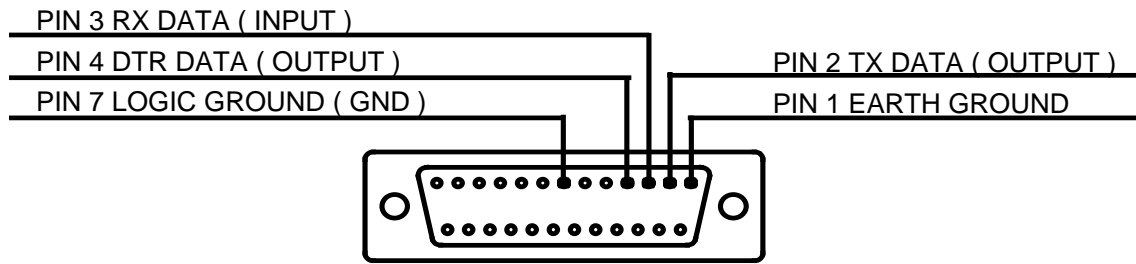

Pic. 5 Serial connector

1.9.1 CONNECTING PRINTER TO 9 PINS PC SERIAL PORT

25 pins Printer	9 pins PC	Sh. Circ. PC side
1 EARTH	N.C.	Hw DTR Protoc.: 1 – 4 – 6
2 TX	2	
3 RX	3	Sw XON-XOFF Protoc.: 7 – 8 1 – 4 – 6
4 DTR	8	
7 GND	5	

1.9.2 CONNECTING PRINTER TO 25 PINS PC SERIAL PORT

25 pins Printer	9 pins PC	Sh. Circ. PC side
1 EARTH	N.C.	Hw DTR Protoc.: 6 – 8 – 20
2 TX	3	
3 RX	2	Sw XON-XOFF Protoc.: 4 – 5 6 – 8 – 20
4 DTR	5	
7 GND	7	

CH. 2: STANDARD PROGRAMMING MODE

When printer is turned on, it is in **standard programming mode**; on display there is the message:

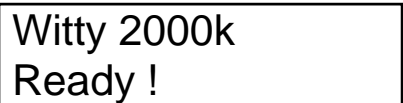

Witty 2000k
Ready !

Standard programming mode display

When printer is in this mode it's possible to download all informations needed. In particular:

- Layouts for labels
- Database for ingredients
- List of products (PLU)

For a complete overview about programming operations see chapter "Storing data into printer".

When printer works in standard mode, you can check all the general working parameters by pressing MENU key (see paragraph concerning MENU key).

2.1 F1 KEY: PROGRAMMED DATA STORING

During the standard mode, F1 key is used to store all programmed informations into printer permanent memory.

While printer is saving data, it shows next message on display:

```
Saving Memory...
>>>>
```

The second line, while saving goes on, will be completely filled with '>' characters.

The complete saving of memory takes about 8 seconds.

WARNING:

If during the data storing phase printer is turned off or there is a fall down of power line, it will be necessary to program again printer by ETIK.

2.2 F2 KEY: SETTINGS OF EURO CHANGE AND ACTIVE PLU NUMBER

During the standard mode, F2 key let you set the correct change for EURO money.

Pressing F2 key you'll see:

```
1 EURO = xxx.xxx
New > _
```

The current change value is displayed. You can set another value by inputing it with numeric keys. The decimal dot can be written keeping pressed the SHIFT key and pushing '3YZ.' key too. Press ENTER to validate new value, ESC to abort.

Next new display will appear:

```
Activate PLU n°:
xxx
```

Now it is possible to set a specific number of merceologic record (PLU).

Press ENTER to validate new record, ESC to abort.

New entered record will be automatically activated when you will enter the PLU mode.

If you have never programmed the merceologic database the default for this value is -1 (that means no PLU stored).

2.3 F3 KEY: PLU (MERCEOLOGIC) MODE

By pressing F3 key in standard mode you can enter the PLU mode (see chapter 3).
If no PLU record has been programmed by user, this section will be empty, F3 key will be of no effect and display won't change.

2.4 F4 KEY: INTERNAL CLOCK SETTING (DATE AND HOUR)

When printer is in standard mode and you press F4 key the next message will appear on display:

Date: dd/mm/yyyy
new: _ / _ /

In the first line the current date has displayed (in format Day/Month/Year).

You can use the numeric keys to insert new date. After last digit has been inserted, the mask will change automatically to the next one.

If you don't want to change date press ESC to continue.

New mask is:

Time: hh:mm:ss
new: _ : _ :00

and it is useful to change the hour internally stored into real time clock.
The first line shows current hour in the format Hours:Minutes:Seconds.

You can insert new values for hours and minutes with numeric keys.

If you don't want to change hour press ESC to continue.

After last digit of minutes (or ESC key) the display will come back to main menu of standard mode.

2.5 F5 KEY: AUTOMATIC CONVERSION NATIONAL MONEY → EURO (€)

When printer is working in standard programming mode you can press F5 key to enter procedure to convert internal money from National to Euro or vice versa.

Before transformation you will be able to insert the change value.

This procedure will transform all next quantities (referring to PLU informations):

- Unit Price of all stored PLU
- Partial Total
- General Total
- Grand Total

For each PLU record stored into printer, the link to layout to use will be updated.

Depending of which value is actually in use, you can see the next two messages (the first when it works in national money, the second when it works in EURO money)

Conversion:
POUNDS → EURO

Conversione:
EURO → POUNDS

Press ENTER to validate conversion, ESC to abort procedure and come back to main menu.

Label layouts available during National money work:

For products they are:	A - B - C - D - E - F - G - H - I - J
For Grand Total it is:	Y
For Partial and General total it is:	Z

Label layouts available during Euro money work:

For products they are:	K - L - M - N - O - P - Q - R - S - T
For Grand Total it is:	W
For Partial and General total it is:	X

Example:

If during National Money operations PLU n° 4 was linked to product layout D, after the conversion the same PLU will be linked to product layout N; moreover, the layouts for totals will be W and X.

2.6 F6 KEY: REMOTE TERMINAL MODE

When printer is working in standard programming mode you can press F6 key to enter Remote Terminal mode.

This mode let you use printer keyboard to send strings to an external device via serial port.

Each of 24 keys can be related to a string up to 5 characters long.

When printer is working in remote terminal mode, each time you press one key printer will send the corresponding string out to serial port.

To press F6 key will cause to come back to standard mode.

Strings can be programmed via software by the command:

?R0&KeyIndex,String , where

KeyIndex Index corresponding to key you want to program

String String to be related to key

Here there are all keys indexes:

KEY	INDEX	KEY	INDEX
MENU	0	UP ARROW	12
7	1	F3	13
8	2	F4	14
9	3	ENTER	15
BKSP	4	0	16
F1	5	1	17
F2	6	2	18
ESC	7	3	19
SHIFT	8	DOWN ARROW	20
4	9	F5	21
5	10	F6	22
6	11	PRINT	23

Example:

?R0&7,ESC

?R0&15,ENTER

With this example you associate key ESC to string “ESC” and key ENTER to string “ENTER”.

2.7 MENU KEY: GENERAL WORKING PARAMETERS

When printer is working in standard programming mode, if you press MENU key you'll be able to set all printer general working parameters. They are:

- Serial port BAUD RATE
- Serial port Parity
- Serial port Data bit number
- Serial port Stop bit number
- Media to use: Labels, Tags or Continuous Paper
- Label taken photosensor: On / Off
- Preprinted Labels: Yes / No
- Y Gap (at the end of printing in label mode)
- Transmission of character SUB (1A Hex = 26 Dec) at the first status request after power on
- Macro Interpreter: On / Off
- National character Set (USA, Italy, Sveden, Norway, France, German, UK)
- RTS control serial line level: Standard RS232 / Logically Inverted
- Optoisolated input signal for Print Consent (Pick & Place)
- Optoisolated output signal for Print End

WARNING:

All parameters must be confirmed with ENTER key or aborted with ESC key.

When you press ESC key you are going to abort only the last parameter you see on display: the previous already confirmed by ENTER are considered valid.

In the next pages you'll find the description of each of above parameters.

2.7.1 SERIAL PORT BAUD RATE

From main menu press MENU key to display next message:

Com – BAUD :
9600

You can modify this parameter by using UP and DOWN keys.

Available values are:

- 2400
- 4800
- 9600
- 19200
- 38400
- 57600

When you reach the correct value, press ENTER to validate it and go to the next parameter or ESC to abort and come back to main menu.

2.7.2 SERIAL PORT PARITY

Next message is for serial port parity:

Com – PARITY :
None

You can modify this parameter by using UP and DOWN keys.

Available values are:

- None
- Odd
- Even

When you reach the correct value, press ENTER to validate it and go to the next parameter or ESC to abort and come back to main menu.

2.7.3 SERIAL PORT DATA BIT

Next message is for serial port Data bit:

Com – DATA bits :
8 bit

You can modify this parameter by using UP and DOWN keys.

Available values are:

- 8 bit
- 7 bit

When you reach the correct value, press ENTER to validate it and go to the next parameter or ESC to abort and come back to main menu.

2.7.4 SERIAL PORT STOP BIT

Next message is for serial port Stop bit:

Com – STOP bits: 1 bit

You can modify this parameter by using UP and DOWN keys.

Available values are:

- 1 bit
- 2 bit

When you reach the correct value, press ENTER to validate it and go to the next parameter or ESC to abort and come back to main menu.

2.7.5 MEDIA TYPE

Next message is for Media type:

Paper mode : Continuous

You can modify this parameter by using UP and DOWN keys.

Available values are:

- Tags
- Continuous media
- Labels

When you reach the correct value, press ENTER to validate it and go to the next parameter or ESC to abort and come back to main menu.

2.7.6 LABEL TAKEN PHOTOSENSOR

Next message is for label taken photosensor.

If label taken photosensor is on, printer cannot eject any other label until the one under photosensor has been removed.

Label Taken:
Disabled

You can modify this parameter by using UP and DOWN keys.

Available values are:

- Enabled
- Disabled

When you reach the correct value, press ENTER to validate it and go to the next parameter or ESC to abort and come back to main menu.

WARNING: Label taken photosensor is not included into standard printer configuration, but it must be ordered as option.

2.7.7 PREPRINTED LABELS

Next message is for preprinted labels. We mean with these words a label which includes some coloured or black areas (words, drawings, etc...).

Preprinted label
Disabled

You can modify this parameter by using UP and DOWN keys.

Available values are:

- Enabled
- Disabled

When you reach the correct value, press ENTER to validate it and go to the next parameter or ESC to abort and come back to main menu.

WARNING: When this feature is on, follow instructions into paragraph “Start up with pushed PRINT button” to initialize printer correctly

2.7.8 LABEL ALIGNEMENT: Y GAP

Next parameter makes you able to regulate the Y alignment of label (in paper feed direction) when printer is working in label mode.

WARNING: Y GAP has no effect if printer is working in “Continuous paper” mode

The message you’ll see is the next one:

```
Y align. (dots):  
GAP: 0
```

You can modify this parameter by using UP and DOWN keys.

Available values are all in the range:

- - 255
- + 255

This parameter is expressed in dot unit. To input significative values you must consider the printing resolution of your printer model (Witty2000K model has a resolution equal to 8 dots/mm).

- The value 0 (zero) guarantees a correct position for dispensing labels.
- Negative values will cause label staying, after printing, more inside with respect to 0 value.
- Positive values will cause label staying, after printing, more outside with respect to 0 value.

To set correctly GAP parameter follow next steps:

- 1 Press MENU button on keyboard and check the media is different from Continuous paper
- 2 Press ENTER button till you reach message for GAP parameter. Set zero value and validate by pressing ENTER button
- 3 Come back to main menu by pressing ENTER button sometimes: printer will realigne
- 4 Press MENU button again and go till GAP message by pressing ENTER sometimes, then set requested value and validate by ENTER button
- 5 Come back to main menu by pressing ENTER button sometimes: printer will realigne
- 6 Repeat points 4 and 5 until you obtain the correct label alignment

The value set to GAP parameter will be kept into permanent memory even if printer will be turned off.

Each time you change the Y GAP parameter printer will execute a realignement of labels.

NOTE: See also the “Y offset adjust” parameter in ETIK program: you can find it into window “File – Printer setup...”

2.7.9 VOLTAGE DROP MONITORING

This parameter is useful to check, via serial port, if some voltage drop has happened. The message you'll see is the next one:

SUB at power on: Disabled

You can modify this parameter by using UP and DOWN keys. Available values are:

- Enabled
- Disabled

When you reach the correct value, press ENTER to validate it and go to the next parameter or ESC to abort and come back to main menu.

You can check the printer status via serial port by immediate command: **!0**
When printer receives this command it replies via serial port by sending one character codifying its status.

Following table summarizes the possible printer status answers:

Character 06 Hex	OnLine status (normal operativity)
Character 1A Hex	Power voltage has dropped down
Character 15 Hex	Syntax error into commands or parity error into serial communication. Press ESC button to resume normal operativity
Character 07 Hex	End of paper status. Press PRINT button to resume normal operativity after having changed label roll

After dropping of power voltage, only for the first time you check it, printer will reply (if above parameter is enabled) hexadecimal character 1A.

2.7.10 MACRO-INTERPRETER MODE

Next parameter is useful to enable or disable the Macro-Interpreter working mode. See the Programming manual for all details related to Macro mode.

The message you'll see is the next one:

MACRO status:
Disabled

You can modify this parameter by using UP and DOWN keys.

Available values are:

- Enabled
- Disabled

When you reach the correct value, press ENTER to validate it and go to the next parameter or ESC to abort and come back to main menu.

2.7.11 NATIONAL CHARACTERS SET

Next parameter is useful to choose the national set for ASCII characters to print. Please refer to programming manual for all needed details.

The message you'll see is the next one:

Character Set:
UK

You can modify this parameter by using UP and DOWN keys.

Available values are:

- UK
- Germany
- France
- Norway
- Sweden
- Italy
- U.S.A.

When you reach the correct value, press ENTER to validate it and go to the next parameter or ESC to abort and come back to main menu.

2.7.12 SERIAL RTS CONTROL LINE LEVEL

Next parameter is useful to set the working logic of serial control RTS signal. Two working modes are: standard RS232 or logically inverted.

The message you'll see is the next one:

RTS Busy Level
Standard

You can modify this parameter by using UP and DOWN keys. Available values are:

- RS232 Standard
- Logically inverted

When you reach the correct value, press ENTER to validate it and go to the next parameter or ESC to abort and come back to main menu.

2.7.13 INPUT 'PICK & PLACE' SIGNAL

Next parameter is useful to enable or disable the input 'Pick & Place' signal. When this signal is enabled, printing operations can be controlled by an external device.

Please refer to programming manual for all needed details.

The message you'll see is the next one:

P & P Signal
Disabled

You can modify this parameter by using UP and DOWN keys. Available values are:

- Enabled
- Disabled

When you reach the correct value, press ENTER to validate it and go to the next parameter or ESC to abort and come back to main menu.

WARNING: The connector for P&P signal (which will be mounted on frontal panel) is not included into printer standard configuration; it must be ordered as option

2.7.14 END OF PRINT SIGNAL

Next parameter is useful to control the working mode of output 'End of Print' signal.

Printer manages one output line which reports the status of printing operations to an external device. This signal can be activated in two different ways: during the whole printing operation or 250 msec. long starting from the end of printing.

Please refer to programming manual for all needed details.

The message you'll see is the next one:

End Print Signal
Disabled

You can modify this parameter by using UP and DOWN keys.

Available values are:

- Signal activated during whole printing operation
- Signal 250 milliseconds long starting from the end of printing operations
- Disabled

When you reach the correct value, press ENTER to validate it or ESC to abort and come back to main menu.

WARNING: The connector for End of Print signal (which will be mounted on frontal panel) is not included into printer standard configuration; it must be ordered as option

2.8 PRINTING INTENSITY MODIFYING

2.8.1 MANUAL MODIFYING (UP / DOWN ARROW KEYS)

When printer works in programming mode, that is it runs its main menu, it's possible to modify the printing intensity.

Printing intensity is expressed in percent and it can change into range 0% – 100%.

We cannot say there is an always good value for printing intensity; it is closely related to kinds of media (labels, ink ribbon, etc...) one is using and it must be found by making practical tests of printing.

Press UP arrow key to increase the printing intensity.
Press DOWN arrow key to decrease the printing intensity.

In both cases the message you'll see is the next one:

Witty 2000k
Head power: xx%

The shown percent (xx%) will change while you'll keep button pressed.
Last value set will be kept into permanent memory even if printer will be turned off.

2.8.2 SOFTWARE MODIFYING

If printer is connected to a PC, it's possible to control the printing intensity by software command `?77&Percent` which must be sent via serial port to printer.
Parameter *Percent* expresses the percent of intensity to use.

Esempio:
`?77&30` Questo comando imposta l'intensità di stampa al 30%

Please refer to Programming manual for further details.

WARNING: A too high printing intensity might reduce the lifetime of thermal print head.

2.9 SECURITY PASSWORD MODIFYING (SHIFT + MENU KEYS)

All printers have a three digits password. You'll be asked for it as security control before doing some particular erasing operations (see ahead).

All printers are factory initialized with password "000" (three zeros) but it can be changed by user.

When printer works in main program menu, keep SHIFT key pressed and press MENU key too, then release them both. You'll see next message on display:

```
Old Password
> ???
```

Type in the old password you want to change using numeric keys (asterisks will be displayed instead of real digits).

The message you'll see is the next one:

```
New Password
> ???
```

Now type in new password using numeric keys (asterisks will be displayed instead of real digits). After the third typed digit you'll see the next message:

```
Type it again
> ???
```

Now type in again new password to confirm it.

If all matches, just after the third typed digit the display will come back to main menu and new password will be stored; otherwise the operation will be aborted and the next message will be displayed before coming to main menu:

```
Type it again
Wrong !!
```

2.10 MEMORY RESET (BKSP + ENTER KEYS)

It is possible to erase all data stored into permanent memory.

This operation will erase from internal permanent memory all label layouts, all fixed tests and barcodes, all graphic images (logos) and all merceologic section.

To avoid the risk to erase unintentionally all data, before this operation starts you are asked for the protection password.

When printer works into main menu, keep pressed BKSP key and press ENTER key too, then release them both.

You'll see the next message:

```
Enter Password
>   ???
```

Input now the three digits password.

If password is correct the erasing will begin and you'll see next message:

```
General Reset:
Wait please...
```

If password is not correct you'll see next message for some second, then printer will come back to main menu:

```
Enter Password
Wrong !!
```

2.11 DISPLAYING PRINTED METERS (ENTER + DOWN ARROW KEYS)

When displays shows next message:

Witty 2000k Ready !

Keep pressed ENTER key and press also DOWN ARROW key.
On display you'll see informations about:

- Number of ejected labels
- Total ejected meters
- Total printed meters (with head heating)

At the end of informations display will come back to the main menu message.

CH. 3: “PLU” MODE

- Products (PLU): up to 500.
- Ingredients into DataBase: about 1500.
- Number of totals: 3 (Partial Total – General Total – Grand Total).
- Each PLU has up to 5 text fields for product description. Each description field can be up to 50 characters long.
- Each PLU can be of two different types: **weight** or **no weight**.
- PLU variable fields modifying by printer keyboard.
- 26 label layouts: names from A to Z.
- Data programmable by PC “Etik” program.

To enter into “PLU” mode press F3 key when printer is in main menu.

If any PLU has never been programmed, F3 key will have no effect.

To exit from PLU mode press ESC key and wait for end of memory saving: then you can turn off printer.

The PLU main menu is the next message:

PLU=0000 LAY='A' AUTO STAND ALONE

PLU=0000	Number of active PLU
LAY='A'	Layout associated to active PLU
AUTO (or MAN.)	Automatic or Manual mode
CORPO	Type of product (see below the possibilities)

3.1 FOUR PLU TYPES DESCRIPTION

PLUs can be divided into next four families:

- 1) STAND ALONE it doesn't need any field from scale
- 2) STD WEIGHT weight and tare from scale
- 3) SLAVE WEIGHT weight, tare, unit price and amount from scale
- 4) BCD WEIGHT customized kind of PLU

Let's see them more in detail.

3.1.1 STAND ALONE PLU

This kind of PLU is shown on printer display by message “STAND ALONE” and it doesn’t need any data field from external devices (such as scales, PLC or other weighing serial devices). Once you have selected number of PLU, you must press ENTER key to print a label.

Amount: it is composed using data from Amount field into PLU record.

Printing of a Stand Alone PLU

After having programmed correctly PLUs and label layouts by ETIK, press F3 to start PLU mode. Select, with numeric keys, which PLU you want to use and be sure display shows message “STAND ALONE”.

Now press ENTER key to print label.

After the first label has been printed you’ll be prompted for number of some other batch copy to do; these copies are included into totals calculation.

If you want to repeat last printed label without totalizing it you can press PRINT key.

3.1.2 STANDARD WEIGHT PLU

This kind of PLU is shown on printer display by message “STD WEIGHT”. It needs two fields from scale:

- Net Weight
- Tare

Amount: automatically calculated by printer as product between Net Weight (read from scale) and Unit Price (stored into PLU record).

Printing of a Standard Weight PLU

After having programmed correctly PLUs and label layouts by ETIK, press F3 to start PLU mode. Select, with numeric keys, which PLU you want to use and be sure display shows message “STD WEIGHT”.

Make a weighing to compose and print a label.

If printer is working in AUTOMATIC mode, the printing will be done as soon as scale has sent its data record.

If printer is working in MANUAL mode you’ll need to press PRINT key to have label printed.

If you want to repeat last printed label without totalizing it you can press PRINT key.

3.1.3 SLAVE WEIGHT PLU

This kind of PLU is shown on printer display by message "SLAVE WGHT". It needs four fields from scale:

- Net Weight
- Tare
- Unit Price
- Amount

Amount: in this case it is read directly from scale. Printer doesn't make any calculation, above variable fields are printed as they arrive from scale.

Printing of a Slave Weight PLU

After having programmed correctly PLUs and label layouts by ETIK, press F3 to start PLU mode. Select, with numeric keys, which PLU you want to use and be sure display shows message "SLAVE WGHT".

Make a weighing to compose and print a label.

If printer is working in AUTOMATIC mode, the printing will be done as soon as scale has sent its data record.

If printer is working in MANUAL mode you'll need to press PRINT key to have label printed.

If you want to repeat last printed label without totalizing it you can press PRINT key.

3.1.4 BCD WEIGHT PLU

This kind of PLU is shown on printer display by message "BCD WEIGHT". It must be used when the scale sends a 13 bytes long record in BCD format.

The fields read from scale are:

- Tare
- Net Weight
- Unit Price
- Amount

Amount: in this case it is read directly from scale. Printer doesn't make any calculation, above variable fields are printed as they arrive from scale.

Printing of a BCD Weight PLU

After having programmed correctly PLUs and label layouts by ETIK, press F3 to start PLU mode. Select, with numeric keys, which PLU you want to use and be sure display shows message "BCD WEIGHT".

Make a weighing to compose and print a label.

If printer is working in AUTOMATIC mode, the printing will be done as soon as scale has sent its data record.

If printer is working in MANUAL mode you'll need to press PRINT key to have label printed.

If you want to repeat last printed label without totalizing it you can press PRINT key.

3.2 LABEL LAYOUTS FOR “PRODUCTS” (PLU)

Each label layout can contain fixed and variable tests.

3.2.1 FIXED TESTS

Fixed tests stored into printer permanent memory can be up to 200 and each of them can be up to 50 characters long.

One fixed test is written when you are defining the label layout and it remains always the same for all label created using that layout.

You can see the layout used by each PLU on printer display: “LAY=‘...’”.

3.2.2 VARIABLE TEXTS

Variable text can be filled with different data each time.

All labels for products (it means for PLUs) must contain the following variable fields, with the listed order:

1. Product name n° 1
2. Product name n° 2
3. Product name n° 3
4. Net Weight
5. Tare
6. Unit Price
7. Packing date
8. Seasoning date
9. Best Before date
10. Amount in National money
11. Amount in Euro money (€)
12. Barcode. The barcode can be composed by a fixed part (strictly related to used product) and by a variable part (coming from Net Weight or Amount).
13. Product name n° 4
14. Product name n° 5
15. Printed labels incremental counter
16. Facultative fields read from external serial device

You can choose, for each PLU, which variable field must be printed and which must not.

This choice can be done directly in a programming phase from PC or modified manually later from printer keyboard.

Variable fields note

Variable fields listed above must always be present into product layouts, even if some of them aren't useful and must not be printed.

The lack of some variable field will cause, quite surely, an error during the composition of label.

You can drop into a corner of label all unuseful variable fields: they will be let empty if you have programmed correctly the PLU table.

3.2.3 INGREDIENTS LIST

Each PLU can have one ingredient field; the number of ingredients related to a PLU is limited only by label phisic dimensions.

You can choose ingredients (from the list stored into database) using ETIK program, but you will be able to modify them also manually by printer keyboard.

3.3 LABEL LAYOUTS FOR “PARTIAL” AND “GENERAL” TOTALS

Layouts X (in Euro money mode) and Z (in National money mode) are used by “Partial Total” and “General Total”: these two layouts cannot be used by PLUs.

All labels for Partial and General Total must contain the following variable fields, with the listed order:

1. Type of total (Partial or General)
2. Product name n° 1
3. Product name n° 2
4. Product name n° 3
5. PLU index
6. Total of printed labels
7. Total of Net Weight
8. Total of national money Amount
9. Barcode
10. Total of Euro money
11. Product name n° 4
12. Product name n° 5

3.4 LABEL LAYOUTS FOR “GRAND TOTAL”

Layouts W (in Euro money mode) and Y (in National money mode) are used by “Grand Total”: these two layouts cannot be used by PLUs.

All labels for Grand Total must contain the following variable fields, with the listed order:

1. Type of total
2. Total of printed labels
3. Total of Net Weight
4. Total of national money Amount
5. Barcode
6. Total of Euro money

3.5 KEYS AND FUNCTIONS IN PLU MODE

Shift	Swap between MANUAL / AUTOMATIC mode
ESC	Back to previous menu
0...9	Numeric selection of PLU to use
UP arrow	Activation of next PLU
DOWN arrow	Activation of previous PLU
Enter	For Stand Alone PLUs composition and printing of label
Menu	Setup of next working parameters: <ul style="list-style-type: none">- N° of decimal digit into Net Weight (only BCD PLUs)- N° of decimal digit into Tare (only BCD PLUs)- N° of decimal digit into Amount (only BCD PLUs)- N° of decimal digit into Total Weight- Scale Record type: <i>Fixed Length</i> or <i>Terminator character</i>- Record length / ASCII code of terminator character- Serial security protocol: On / Off- Starting value setting for printed labels incremental counter- Maximum printable lot setting- Maximum printable lot: On / Off
Print	Print again the last label ejected without totalizing
F1	PLU names modification
F2	Unit Price modification
F3	Packing, Seasoning and Best Before dates modification
F4	On / Off for all variable fields. It let you access a submenu to enable, disable or modify the next fields of PLU label: <ul style="list-style-type: none">• Product name n°: 1, 2, 3, 4 and 5• Net Weight• Tare• Unit Price• Incremental counter• Amount in National money and Euro• Barcode. You can set:<ol style="list-style-type: none">1. Type: EAN13, EAN8 or UPCA2. Fixed / Variable3. Variable data to be read from Weight or Amount4. Digits for fixed part of barcode5. Number of variable digits to use• Database new texts appendage• Active PLU's ingredients field modifying<ol style="list-style-type: none">1. Co-ordinate X2. Co-ordinate Y

3. Printing Direction
4. N° of characters in each line
5. N° of ingredients to be printed
6. Selection of ingredients by index

F5 Copy active PLU and append it as last of the list

F6 Totals management. It let you access a submenu to print or erase all totals. If now you press **F4** you can reach a further submenu to set all parameters of variable fields into Grand Total label:

- Type of total
- N° of printed labels
- Net Weight
- Amount in National money and in Euro
- Barcode. You can set:
 1. Type: EAN13, EAN8 or UPCA
 2. Fixed / Variable
 3. Variable data from Weight or Amount
 4. Fixed digit into barcode
 5. Number of variable digit to use

BKSP + UP arr. Link to next label Layout

BKSP + DOWN arr. Link to previous label Layout

3.6 PLU OPERATIONS

3.6.1 SWAP MANUAL / AUTOMATIC MODE (SHIFT KEY)

The selection Manual/Automatic let you choose the way of printing.

Manual: to have a label printed you must validate it by PRINT key.
Before each printing the message on display will be:

```
Label Composed:  
PRINT or ESC ?
```

Press PRINT key to print or ESC key to abort.

Automatic: printer prints automatically as soon as all variable fields have been composed.

The Manual / Automatic selection can be done from PLU main menu: each time you press SHIFT key you'll see the second line of display changing between "MAN." and "AUTO".

3.6.2 PLU SELECTION

Each PLU can be chosen and activated from PLU main menu.
The message on display will be:

```
PLU=0000 LAY='A'  
MAN. STD. WEIGHT
```

(PLU main menu)

There are 2 ways to select and activate PLU:

1. Using UP and DOWN arrow keys to increase or decrease (step 1) the number of PLU.
2. Writing manually the number of PLU using numeric keys and validating it by ENTER key. If number is greater than the last stored PLU you'll see the message:

```
WARNING !!  
PLU Out of Range
```

Press any key to go back to main PLU menu.
If you entered a valid PLU number you'll see the message:

```
Saving Memory...  
>>>>
```

The second line, while saving goes on, will be completely filled with '>' characters.

When saving has finished the display will go back to main PLU menu.

3.6.3 PRINTING OF A “STAND ALONE” PLU (ENTER KEY)

When the selected PLU is of “Stand Alone” kind, its printing can be obtained by pressing ENTER key on printer.

Depending on working mode of printer (Manual or Automatic) you could need to press PRINT key to validate the printing.

After first label has been printed you’ll see next message on display:

Copies to print:
> _

Now it’s possible to input the number of identical copies you want. Use numeric keys to compose number and press ENTER key to confirm value or ESC key to go back to main PLU menu without printing any label.

All copies here done will be added to totals count.

If incremental counter was enabled into label, it will be updated at each printed label.

3.6.4 CHANGE OF 5 PRODUCT NAMES (F1 KEY)

It is possible to change each of 5 product description texts manually by printer keyboard..

Into all next messages you can press ESC to escape and come back to main PLU menu.

When printer works in main PLU menu press F1 key to have next message displayed:

Change Text n° :
1, 2, 3, 4 or 5 ?

Now press key 1, 2, 3, 4 or 5 depending on what text you want to modify.

Next message will be displayed:

Choose: 1 = Index
2 = New Text

Now you have two ways to modify the selected product description:

First way: using a text read from database

Press the numeric key 1 to use a text read from database.

Next message will be displayed:

Choose Text n°:
> _

Now you can input the index of text you want to read from database.

Press ENTER to validate index. Printer will come back to main PLU menu.

Second way: new text manually written

Press the numeric key 2 to write manually new text.

Next message will be displayed:

New PRODUCT:
(24) _

Now you can write new text using alphanumeric keys.

If you press many times the same key before underscore goes ahead you will see displayed all letters and digits of that key.

SHIFT key is useful to swap between uppercase and lowercase letters.

BKSP key is useful to move and delete the letter or digit on the left of cursor. You can use this key to correct writing errors.

When you finish writing, let cursor go ahead and then press ENTER to validate new text.

New written text will be appended at the end of database and its index will be the one visualized into brackets.

After inserting, display will come back to main PLU menu.

3.6.5 CHANGE OF UNIT PRICE (F2 KEY)

You can modify Unit Price manually by printer keyboard.

When printer works in main PLU menu press F2 to see next message:

Price: 6.50
new: _

Now you have only to digit new price value and then press ENTER. Press ESC to abort modifying. (REMEMBER: Decimal points = SHIFT + '3' keys).

At the end of modifying printer will go back to main PLU menu.

WARNING: If selected PLU is "Stand Alone" type, Unit Price will be used as Amount

3.6.6 CHANGE OF DATES: PACKING, SEASONING AND BEST BEFORE (F3 KEY)

You can modify Packing, Seasoning and Best Before dates manually by printer keyboard.

Packing Date

From main PLU menu press F3 key to have next message:

Packing Date:
0=NO 1=AUT 2=MAN

Cursor will blink on digit 0, 1 or 2, depending on the current Packing date mode (referred to active PLU).

Cursor blinking on 0: Packing date is not printed.

Cursor blinking on 1: Packing date is printed in automatic mode using internal clock.

Cursor blinking on 2: Packing date was entered manually.

To go directly to next date skipping Packing date press ENTER.
To go back to main PLU menu press ESC.
To change Packing date current settings press '0', '1' or '2' keys.

- '0' key: Packing date won't be printed
- '1' key: Automatic date: internal clock date will be used
- '2' key: Manual date: you can input manually a date that will be used as Packing date. Pressing this key you'll see next message:

Packing Date:
new: _ / /

The date here entered will be used as Packing date **by all PLUs stored** (of course only where it is enabled). Seasoning and Best Before dates will be calculated starting from this manually entered date.

Press ESC key to go on without modifying Packing date.

Seasoning Date

The starting message is:

Seasoning:
0=NO 1=AUT 2=MAN

Cursor will blink on digit 0, 1 or 2, depending on the current Seasoning date mode (referred to active PLU).

- Cursor blinking on 0: Seasoning date won't be printed.
- Cursor blinking on 1: Seasoning date is printed in automatic mode: packing date will be added with programmed seasoning days to obtain Seasoning date.
- Cursor blinking on 2: Packing date was entered manually.

To go directly to next date skipping Seasoning date press ENTER.
To go back to main PLU menu press ESC.
To change Seasoning date current settings press '0', '1' or '2' keys.

- '0' key: Seasoning date won't be printed
- '1' key: Automatic date: you can input manually the seasoning days. Next message will be:

Seasoning:
0060 → _

The number displayed (in this case "0060") represents the seasoning days programmed for active PLU; you can input a new value to modify the previous one.

Once you have written the new number of days, press ENTER to validate it.

To go ahead without changing press ESC key.

- '2' key: Manual date: you can input manually a date that will be used as Seasoning date. Pressing this key you'll see next message:

Seasoning:
new: _ / /

The date here you insert will be used as Seasoning date and it will be valid for **all PLUs** stored.
To go ahead without changing the Seasoning date press ESC key.

Best Before date

The starting message is:

```
Best Before:
0=NO 1=AUT 2=MAN
```

Cursor will blink on digit 0, 1 or 2, depending on the current Best Before date mode (referred to active PLU).

Cursor blinking on 0: Best Before date won't be printed.

Cursor blinking on 1: Best Before date is printed in automatic mode: packing date will be added with programmed validity days to obtain Best Before date.

Cursor blinking on 2: Best Before date was entered manually.

To go directly to main PLU menu skipping Best Before date press ENTER or ESC keys.

To change Best Before date current settings press '0', '1' or '2' keys.

'0' key: Best Before date won't be printed

'1' key: Automatic date: you can input manually the validity days. Next message will be:

```
Best Before:
0010 → _
```

The number displayed (in this case "0010") represents the validity days programmed for active PLU; you can input a new value to modify the previous one.

Once you have written the new number of days, press ENTER to validate it.

To go ahead without changing press ESC key.

'2' key: Manual date: you can input manually a date that will be used as Best Before date. Pressing this key you'll see next message:

```
Best Before:
new: _ / _ / _
```

The date here you insert will be used as Best Before date and it will be valid for **all PLUs** stored.
To finish dates submenu without changing the Best Before date press ESC key.

3.6.7 PLU VARIABLE FIELDS SETTING (F4 KEY)

You can choose to print or not to print each variable field into PLU label.
When printer is working in main PLU menu press F4 to see next message:

Product Name 1: 0=NO 1=YES ESC

Cursor will blink on '0' or on '1' key.

Cursor blinking on 0: Field won't be printed

Cursor blinking on 1: Field will be printed

To go ahead without changing press ENTER key.

Press ESC to go back to main PLU menu.

If you want modify current settings:

- Press '0' key to disable printing of visualized field. To avoid unintentional fields erasing, you will be asked for a confirmation:

Product Name 1: Field OFF ?

Press ENTER to validate field disablement or ESC to let field be printed.

- Press '1' key to enable printing of visualized field.

This submenu makes you able to enable / disable all next listed fields:

- Product Name # 1
- Product Name # 2
- Product Name # 3
- Product Name # 4
- Product Name # 5
- Net Weight
- Tare
- Unit Price
- Printed labels incremental Counter
- Amount in National money
- Amount in Euro money

For all this fields you must repeat always the same above procedure.

After field "Amount in Euro money" you it will be time for Barcode field; it has many settings, so it is shown in detail into next paragraph.

3.6.8 BARCODE SETTINGS

If you press '1' or ENTER key at barcode message you'll see next message on display:

Type:	1=EAN13
2=EAN8	3=UPCA

Cursor will be blinking on current barcode type setting.

You can choose among three types: EAN13, EAN8, UPCA

Press '1' key for EAN13 type

Press '2' key for EAN8 type

Press '3' key for UPCA type

Type EAN13 can be fixed or composed. Two types EAN8 and UPCA can only be fixed.

** EAN13 selection **

If you press '1' key (type EAN13) you'll see next message:

Fixed Barcode ?
0=NO 1=YES ESC

Cursor will be blinking on current field setting.

Your possibilities are:

- '0' key: Barcode will be composed (that is, made by one fixed part and one variable part which can be read from Net Weight or from Amount)
- '1' key: Barcode will be fixed (that is, made by 12 digits stored into PLU record plus one check digit)
- ESC key: Back to main PLU menu

** Composed EAN13 **

If you press '0' key you select a composed barcode. You'll see next message:

Data from ?
1=Weight 2=Price

Cursor will be blinking on current field setting.

Your possibilities are:

- '1' key: Variable part of barcode will come from Net Weight
- '2' key: Variable part of barcode will come from Amount in National Money
- ESC key: Back to main PLU menu

If you press '1' or '2' key you'll go to set the fixed part of barcode.

The message will be:

Fixed Digit: XXXXXXXXXXXX

The second line of display (in our example “xxxxx...”) shows the current setting of this fixed barcode part for active PLU.

To modify them it’s enough to use numeric keys to input new digits.

Press ENTER to validate new digits or ESC to abort.

If you want to keep current digits press ENTER without writing any digit.

Next message makes you able to set the number of variable digits into barcode.

Message will be:

Variable Digits: 5 plus Check

Now, using UP or DOWN arrow keys, it’s possible to choose the desired setting.

You can choose between:

5 variable digits plus middle check

Barcode will be composed as shown below:



5 variable digits without middle check

Barcode will be composed as shown below:



6 variable digits plus middle check

Barcode will be composed as shown below:



6 variable digits without middle check

Barcode will be composed as shown below:



LEGEND:

- F Fixed digit
- V Variable digit
- K Control digit (check)

Press ENTER to validate your selection.

Press ESC to abort operation and go back to main PLU menu.

** EAN8 or UPCA selection **

If you choose an EAN8 or UPCA barcode, you pass directly to next setting: fixed digits.

You'll see next message:

Fixed Digit:
XXXXXXXXXXXX

In this case the second line of display (in our example “xxxxx...”) will show the fixed digits of barcode for active PLU.

To modify them you have to use the numeric keys and input those new.

If you chose an EAN8 you must input 7 digits.

If you chose a UPCA you must input 11 digits.

Press ENTER to validate digits or ESC to abort operation.

To keep current settings unaltered press ENTER without writing any digits.

3.6.9 ADDING NEW TEXTS INTO DATABASE

It's possible to modify manually database (by printer keyboard) and to append new texts.

All new texts will be put at the end of database and printer will assign them an automatic and progressive index.

You must proceed as below:

1. Starting from main PLU menu press F4.
2. Press ENTER some times till display will show next message:

Modify DATABASE?
0=NO 1=YES ** ESC

If you press key '1' you'll see:

New PRODUCT:
(22) _

Now you can input a new text using alphanumeric keys.

If you press many times the same key before cursor goes ahead you'll see all letters, numbers and graphic signs contained under that key.

SHIFT key is useful to swap between uppercase and lowercase letters.

BKSP key is useful to move and delete the letter or digit on the left of cursor. You can use this key to correct writing errors.

When you finish writing, let cursor go ahead and then press ENTER to validate new text.

New written text will be appended at the end of database and its index will be the one visualized into brackets.

ESC will abort the text input.

3.6.10 INGREDIENT FIELD MODIFYING

It's possible to modify manually (by printer keyboard) the Ingredient field of active PLU.

You must proceed as below:

1. Select PLU number which needs its ingredient field to be modified
2. From main PLU menu press F4
3. Press ENTER many times till display will show next message:

Mod. INGREDIENTS
0=NO 1=YES ** ESC

Keys '0' or ESC won't modify anything.

Key '1' will let you modify:

1. X Co-ordinate of ingredients field
2. Y Co-ordinate of ingredients field
3. Printing direction
4. N° of characters per line before automatic newline
5. N° of ingredients to print
6. Index of each ingredient

You'll see current setting of each parameter on display and you'll be able to input new values by printer keyboard.

All new data must be validated by ENTER.

3.6.11 COPYING AN EXISTING PLU INTO A NEW ONE (F5 KEY)

To add a new PLU into the list you can copy a PLU into a new one and then you can modify this last one.

First of all you have to detect and activate a PLU similar to the new one you want to add.

Then press F5 key to make a copy of selected PLU at the end of the list.

If all operations were good, printer will ask you to print ENTER key to activate newly created PLU.

Now you can do on new PLU all changes you need.

If there isn't memory enough to copy PLU, printer shows the next message:

<p>WARNING!! Out Of Memory</p>
--

In this case it is not possible copy any PLU because all memory is used. Press any key to go back to main PLU menu.

3.7 TOTALS MANAGEMENT

Printer is able to manage up to three totals for treated PLUs: **Partial Total, General Totale and Grand Total.**

For each total you can print:

- Number of printed labels
- Net weight
- National money Amount
- Euro money Amount
- Barcode

The barcode can be chosen between EAN13, EAN8, UPCA and it can contain information from weight or amount or be done by fixed digits.

3.7.1 PARTIAL TOTAL

Partial Total refers to active PLU and stores all operations done with it since you activated it.

If you change PLU when you have a nonzero Partial Total, this one is added to the General Total of that article.

Partial Total is cleared when:

- You change PLU
 - You print it
 - You select manually (by printer keyboard) to erase it
-

3.7.2 GENERAL TOTAL

There is a General Total for each product. It sums all operations done with that product since last General Total clearing.

General Total is cleared when:

- You select manually (by printer keyboard) to erase it
-

3.7.3 GRAND TOTAL

Grand Total sums all operations done with all PLUs since last Grand Total clearing.

Grand Total is cleared when:

- You select manually (by printer keyboard) to erase it

3.7.4 MANUAL TOTALS ERASING (F6 KEY)

Starting from main PLU menu, press F6 key to enter next submenu:

TOTALS: 1=Print 2=Erase

Now press '2' key on printer keyboard to see next message:

TOTALS: Delete Partial Total

Now use UP and DOWN arrow keys to select what total will be cleared.

Your choices are:

- Partial Total *only Partial Total will be erased*
- General Total *only General Total of active PLU will be erased*
- Grand Total *only Grand Total will be erased*
- All PLUs *all three Total types will be erased*

When, scrolling, you have reached the desired total, press ENTER to clear it.
ESC will abort erasing and come back to main PLU menu.

3.7.5 PRINTING OF TOTAL LABELS (F6 KEY)

Starting from main PLU menu, press F6 key to enter next submenu:

TOTALS: 1=Print 2=Erase

Now press '1' key on printer keyboard to see next message:

TOTALS: Print Partial Total

Now use UP and DOWN arrow keys to select what total will be printed.

Your choices are:

- Partial Total *Partial Total will be printed*
- General Total *General Total of active PLU will be printed*
- Grand Total *Grand Total will be printed*

When, scrolling, you have reached the desired total, press ENTER to print it.
ESC will abort printing and come back to main PLU menu.

3.7.6 SETTINGS OF GRAND TOTAL LABEL PARAMETERS

You can select manually, by printer keyboard, what fields to print from Grand Total label.
You can select next fields:

- Type of total (heading)
- Number of printed product labels (packets' number)
- Net Weight
- National money Amount
- Euro money Amount
- Barcode

Starting from main PLU menu, press F6 key to enter next submenu:

TOTALS:
1=Print 2=Erase

Now press F4 key on printer keyboard to see next message:

Heading
0=NO 1=YES ESC

Into all next messages cursor will blink on current active setting.

By this message you can choose if to print or not to print string "Grand Total" on label.
Available keys are: '0', '1', ENTER, ESC

Key 0: string "Grand Total" won't be printed
Key 1: string "Grand Total" will be printed
Key ENTER: you go directly to next submenu without changing this one
Key ESC: you come back to Totals menu

Next submenu is:

Packet's Number
0=NO 1=YES ESC

With it you can choose if to print or not to print the number of printed product labels.
Available keys are: '0', '1', ENTER, ESC

Key 0: field won't be printed
Key 1: field will be printed
Key ENTER: you go directly to next submenu without changing this one
Key ESC: you come back to Totals menu

Next submenu is:

Net Weight: 0=NO 1=YES ESC

With it you can choose if to print or not to print the total of Net Weight.
Available keys are: '0', '1', ENTER, ESC

Key 0: field won't be printed
Key 1: field will be printed
Key ENTER: you go directly to next submenu without changing this one
Key ESC: you come back to Totals menu

Next submenu is:

Total Pounds: 0=NO 1=YES ESC
--

With it you can choose if to print or not to print the total of national money Amount
Available keys are: '0', '1', ENTER, ESC

Key 0: field won't be printed
Key 1: field will be printed
Key ENTER: you go directly to next submenu without changing this one
Key ESC: you come back to Totals menu

Next submenu is:

Total Euros: 0=NO 1=YES ESC

With it you can choose if to print or not to print the total of Euro money Amount
Available keys are: '0', '1', ENTER, ESC

Key 0: field won't be printed
Key 1: field will be printed
Key ENTER: you go directly to next submenu without changing this one
Key ESC: you come back to Totals menu

Next submenu is:

Barcode: 0=NO 1=YES ESC

With it you can choose if to print or not to print the barcode.

From this point the sequence of submenus is completely equal to the one shown at paragraph 3.6.8; the only difference is that in this case all settings are referred to Grand Total label.

See paragraph 3.6.8 for further details.

Once finished all changes to fields of Grand Total label you'll go back to Totals menu.

3.8 CHANGING LABEL LAYOUT (BKSP + UP / DOWN KEYS)

Each PLU recalls a label layout.

There are 26 labels layouts and they named with the uppercase letters (A...Z).

You can see the name of layout linked to PLU when printer works in main PLU menu.

The display will message:

```
PLU=0035  LAY='B'  
AUTO STAND ALONE
```

In this example you see “ LAY='B' ”; it means that the layout recalled by PLU n° 35 is 'B'.

Different PLUs can recall and use the same layout.

You can modify manually the link between PLU and layout; this operation must be done when printer works in main PLU menu.

How to increase linked layout (BKSP + UP arrow key)

Printer must work into main PLU menu.

You can increase the linked layout of one unit at a time (for example from 'C' to 'D') by keeping pressed BKSP key and pressing once UP arrow key too; then release them all.

You'll see on display the new name of linked layout.

How to decrease linked layout (BKSP + DOWN arrow key)

Printer must work into main PLU menu.

You can decrease the linked layout of one unit at a time (for example from 'B' to 'A') by keeping pressed BKSP key and pressing once DOWN arrow key too; then release them all.

You'll see on display the new name of linked layout.

WARNING:

Printer doesn't make any control about the real presence of recalled layouts.

Before changing the link between PLU and recalled layout be sure you have correctly programmed (by ETIK) new layout.

3.8 PLU OPTIONS: MENU KEY

During works in PLU mode it's possible to set some parameters. They are:

- # of decimal digits of Net Weight field into product labels (for BCD PLU)
- # of decimal digits of Tare field into product labels (for BCD PLU)
- # of decimal digits of Unit Price and Amount fields into product labels (for BCD PLU)
- # of decimal digits of Net Weight field into totals labels
- Type of input serial record
- Length or Terminator character of serial record
- Full serial protected protocol settings
- Incremental counter settings
- Printing Lot settings: upper number of printable labels
- Printing Lot settings: ON / OFF
- Printing of Partial Total when end of Lot is reached: ON / OFF

Here below you can find each parameter in detail.

3.8.1 DECIMAL DIGITS OF NET WEIGHT INTO PRODUCT LABELS (ONLY BCD)

This parameter is available only if PLU has type "BCD Weight".

If there is no "BCD Weight" product go directly to paragraph 3.8.4

When printer works in main PLU menu press MENU key to see next message:

Decimal Digits Net Weight: 2

The displayed digit is the current setting for number of decimal digits into Net Weight of BCD incoming serial record.

Now with UP / DOWN arrow keys it's possible to change this parameter setting.

Press ENTER to validate change or ESC to abort.

3.8.2 DECIMAL DIGITS OF TARE INTO PRODUCT LABELS (ONLY BCD)

This parameter is available only if PLU has type "BCD Weight".

If you pressed ENTER key at point 3.8.1 you'll be prompted with next message:

Decimal Digits Tare: 3

The displayed digit is the current setting for number of decimal digits into Tare of BCD incoming serial record.

Now with UP / DOWN arrow keys it's possible to change this parameter setting.

Press ENTER to validate change or ESC to abort.

3.8.3 DECIMAL DIGITS OF PRICE/AMOUNT INTO PRODUCT LABELS (ONLY BCD)

This parameter is available only if PLU has type “BCD Weight”.

If you pressed ENTER key at point 3.8.2 you’ll be prompted with next message:

Decimal Digits
Price: 0

The displayed digit is the current setting for number of decimal digits into Price/Amount of BCD incoming serial record.

Now with UP / DOWN arrow keys it’s possible to change this parameter setting.

Press ENTER to validate change or ESC to abort.

3.8.4 DECIMAL DIGITS OF NET WEIGHT INTO TOTAL LABELS

This option is available for all kinds of PLU. If active PLU is a “BCD Weight” type you will see this message after having passed the three here above, otherwise it is the first one.

The message is:

Decimals in to-
tal weight: 3

The displayed digit is the current setting for number of decimal digits into Net Weight of total labels.

Now with UP / DOWN arrow keys it’s possible to change this parameter setting.

Press ENTER to validate change or ESC to abort.

3.8.5 TYPE OF INPUT SERIAL RECORD

This option is available for PLUs with type different from “BCD Weight” and it let you select how printer will recognize the incoming serial record.

You can choose between Fixed Length record or Terminator Character record.

If you have only “BCD Weight” PLUs you can pass immediately to paragraph 3.8.7.

The message is:

Record TYPE ?
FIXED Length

You can see on display the current setting for parameter.

Incoming scale records may be of two different types:

- Fixed length They are composed always by the same number of bytes
- Terminator character They are terminated always by the same character

Now with UP / DOWN arrow keys it’s possible to change this parameter setting.

Press ENTER to validate change or ESC to abort.

3.8.6 LENGTH OR TERMINATOR CHARACTER OF INCOMING SERIAL RECORD

This option is available for PLUs with type different from “BCD Weight”.

Depending on setting of previous parameter you’ll have two different messages.

If incoming serial record is “Fixed length” type, message will be:

Length N° of Bytes: 25

You can see on display the number of characters (bytes) composing the scale record.

Now with UP / DOWN arrow keys it’s possible to change this parameter setting.

Press ENTER to validate change or ESC to abort.

If incoming serial record is “Terminator Character” type, message will be:

Terminator ASCII: 13

You can see on display the ASCII code of record terminator character.

Now with UP / DOWN arrow keys it’s possible to change this parameter setting.

Press ENTER to validate change or ESC to abort.

3.8.7 FULL SERIAL PROTECTED PROTOCOL

This option is available for PLUs with type different from “BCD Weight”.

After having pressed ENTER key at the previous point, you’ll see next message:

Full Protocol Enabled

This option enables or disables the protected serial protocol; this feature eliminates the risk of errors on serial transmission. With this option enabled you can program, besides to the incoming record dimension, the ASCII codes of first and last characters into record.

When this option is enabled, one incoming record is valid only if it matches completely with all programmed parameters.

For example, if printer receives one record having first and last characters correct, but a wrong number of characters into, it passes over and doesn’t make any label printed.

Now with UP / DOWN arrow keys it’s possible to change this parameter setting.

Press ENTER to validate change or ESC to abort.

3.8.8 MANUAL SETTING OF INCREMENTAL COUNTER

This option is available for all types of PLUs.

After having pressed ENTER key at the previous point, you'll see next message:

Start COUNTING
from: 1

The displayed number shows the starting value for automatic counting of printed labels; each time you change active PLU new counting will start from this value.

Now with UP / DOWN arrow keys it's possible to change this parameter setting.

Press ENTER to validate change or ESC to abort.

3.8.9 PRINTING LOT SETTINGS: UPPER NUMBER OF PRINTABLE LABELS

This option is available for all types of PLUs.

After having pressed ENTER key at the previous point, you'll see next message:

Greater Lot
> 100

The displayed number shows the greater number of printable labels in a single lot.

The counting of lot printed labels is reset each time you change active PLU and it restarts from one.

When printer reaches this value (of course only if it is enabled) display will show a message which let operator decide if go on with the remaining printings or abort them.

Now with UP / DOWN arrow keys it's possible to change this parameter setting.

Press ENTER to validate change or ESC to abort.

3.8.10 PRINTING LOT SETTINGS: ON / OFF

This option is available for all types of PLUs.

After having pressed ENTER key at the previous point, you'll see next message:

Greater Lot
Disabled

With this option you can enable or disable the function of Greatest Printing Lot.

If you enable this option, settings at point 3.8.9 are valid.

Counting of each lot starts from 1 when active PLU changes.

Now with UP / DOWN arrow keys it's possible to change this parameter setting.

Press ENTER to validate change or ESC to abort.

3.8.11 PRINTING OF PARTIAL TOTAL WHEN END OF LOT IS REACHED: ON / OFF

This option is available for all types of PLUs.

After having pressed ENTER key at the previous point, you'll see next message:

<p>PART. at lot end Disabled</p>

With this option you can enable or disable the automatic printing of the Partial Total label when the end of Greater Lot is reached.

Counting of each lot starts from 1 when active PLU changes.

Now with UP / DOWN arrow keys it's possible to change this parameter setting.

Press ENTER to validate change or ESC to abort.

CH. 4: ETIK PROGRAM BASIC SETTINGS

Once you have finished the PC installation of ETIK program, follow next instructions.

4.1 SELECTION OF ARCHIVE FILE

First of all you must select which archive you want to use.

An archive is a file with extension “.KPD” and stored on PC hard disk; it may be intended as a temporary swap file which will contain all PLU programming data.

If you have more than one customer, each of them having an own PLU list, it’s enough to assign each customer to a different archive file to keep all PLU lists separated.

Click “*PLU – Files*”; next window will open:

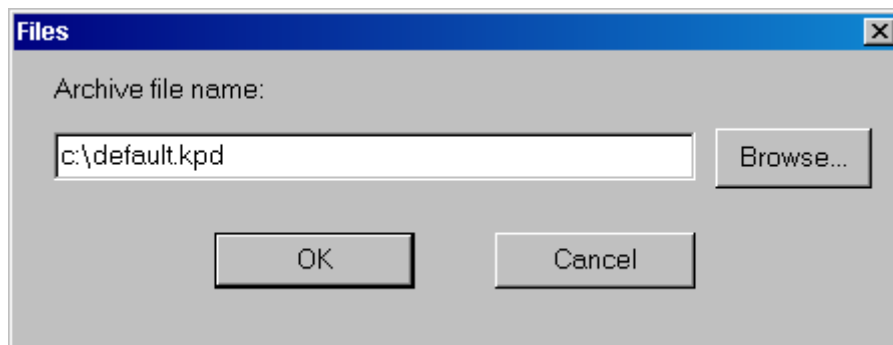

Pic. 6 ETIK: Archive selection

Write path and archive filename into text window or click on *Browse...* button to search hard disk for an existing archive file.

Once you have input the name click on *OK* button to open archive and exit window.

4.2 SCALE PARAMETERS PROGRAMMING WINDOW

Click on “*PLU – Scale setup*” to open next window:

Record types setup

Active device (click on list)

Scale 1 0 250 2 8 10 16 0 0 0 0

OK

Devices list

Scale 1
Scale 2
BCD13

Add

Delete

Serial protocol, protect mode

ASCII Start character: 123

ASCII Stop character: 125

Name Scale 1

Start/Stop pairs

	Start	Stop
Net weight	2	8
Tare	10	16

Additional Start/Stop pairs

Start/Stop pairs

Weight and price from scale

	Start	Stop
Unit price	0	0
Amount	0	0

End of transmission by: Length

Length or Termination: 25

Pic. 7 ETIK: Scale programming window

With this window you can create and set up a list of serial devices (for example scales). This feature will result very useful as each scale transmits data with its own serial protocol; by this window you'll be able to select, each time, the correct serial device you're going to use. Here below there is a detailed description for all windows fields.

Name

Here you must input the name to give to scale. This name will be listed into *Devices list* and it will be used to distinguish different models of scales.

WARNING:

If you prepare BCD record (13 characters long record in BCD format) here you must input the name “BCD13”.

Start/Stop pairs

This section let you program the decoding of fields **Net Weight** and **Tare** from incoming serial data record.

For both fields it is possible to program the Start and Stop position inside the serial record.

When you count the byte positions of fields, consider the first byte of record has index 0 (zero).

WARNING:

If you prepare BCD record (13 characters long record in BCD format) you can leave empty these four boxes.

Start/Stop pairs & Weight and Price from scale

This section let you program the decoding of fields **Unit Price** and **Amount** from incoming serial data record.

This section must be activated and compiled only if the calculation Weight/Price to get Amount is done by serial device. In this case printer will print data without making calculation on them.

For both fields it is possible to program the Start and Stop position inside the serial record.

When you count the byte positions of fields, consider the first byte of record has index 0 (zero).

WARNING:

If you prepare BCD record (13 characters long record in BCD format) you can leave empty these four boxes.

Additional Start/Stop pairs

This section let you program the decoding of other optional fields from incoming serial data record.

The correct syntax for this field is: ***Start / Stop , Start / Stop , ...***

The Start values refer to starting positions of fields inside incoming serial record; the Stop values refer to ending positions of fields inside incoming serial record.

WARNING:

If you prepare BCD record (13 characters long record in BCD format) you can leave empty this text box.

End of transmission by

This section let you choose if incoming serial record will have always the same length (Length) or if it will be always ended by the same character (Termination)

WARNING:

If you prepare BCD record (13 characters long record in BCD format) you must choose “Length” in this text box.

Length or Termination

This section let you program the byte expressed length (if the incoming serial record has a fixed length) or the ASCII code of terminator character (if the incoming serial record is always ended by the same character).

WARNING:

If you prepare BCD record (13 characters long record in BCD format) you must insert number "13" in this text box.

Serial Protocol, protected mode

This section let you program the ASCII code of first (Start) and last (Stop) character of incoming serial record.

When this section is enabled, printer gets valid only incoming data records starting and ending with here programmed characters.

It should be better to use this feature when printer recognizes the incoming serial record by its length; if so, printer will check the total quantity of received characters and it will let down all incoming serial records which don't match these characteristics.

In Picture #7, the record starting character has ASCII code 123 (it is the open double bracket '{'), instead the record ending character has ASCII code 125 (it is the closed double bracket '}'); the total length of record (included these two characters) is 25 characters. Incoming serial records which don't match all these characteristics are ignored and don't produce any printed label.

WARNING:

If you prepare BCD record (13 characters long record in BCD format) you must leave this section unused.

Selection of a device from list

To select a device from list you have just to click on its name.

Creating a new device

To create a new device and to append it at the end of the list you have to compile the above mentioned fields (where it's requested), then you have to click on *Add* button.

Modifying an existing device

First of all you must select it by clicking on its name. All its data will be visualized into text boxes. Now it's possible to change settings and values of every field; new values replace the old when you click on another device or on *OK* button to close window.

Deleting a device from list

Select device to eliminate by clicking on its name into the list, then click on *Delete* button to erase device and all its settings.

4.3 CREATING AN INGREDIENTS DATABASE

Click on “PLU – Ingredients”; the next window will open:

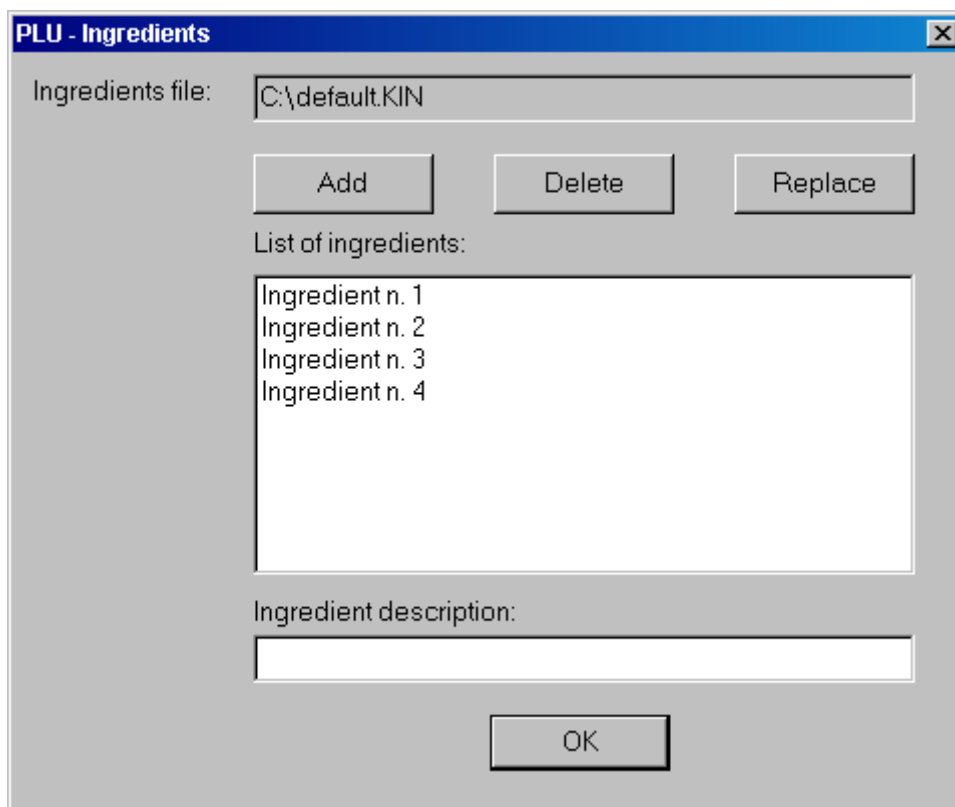

Pic. 8 ETIK: Ingredients Database

This section let you insert, modify or eliminate ingredients into database.

Add ingredients

Write ingredient text into field “Ingredient description” and click on *Add* button.

Modifying ingredients

To modify an ingredient yet present you have only to click on its name into “List of ingredients”, write its new text into field “Ingredient description” and click on *Replace* button.

Erasing ingredients

To erase an ingredient from database click on it and then on *Delete* button.

At the end of operations click on *OK* button to close window and quit.

4.4 CREATING A PRODUCTS DATABASE (PLU TABLE)

Click on “PLU –PLU table”; next window will open:

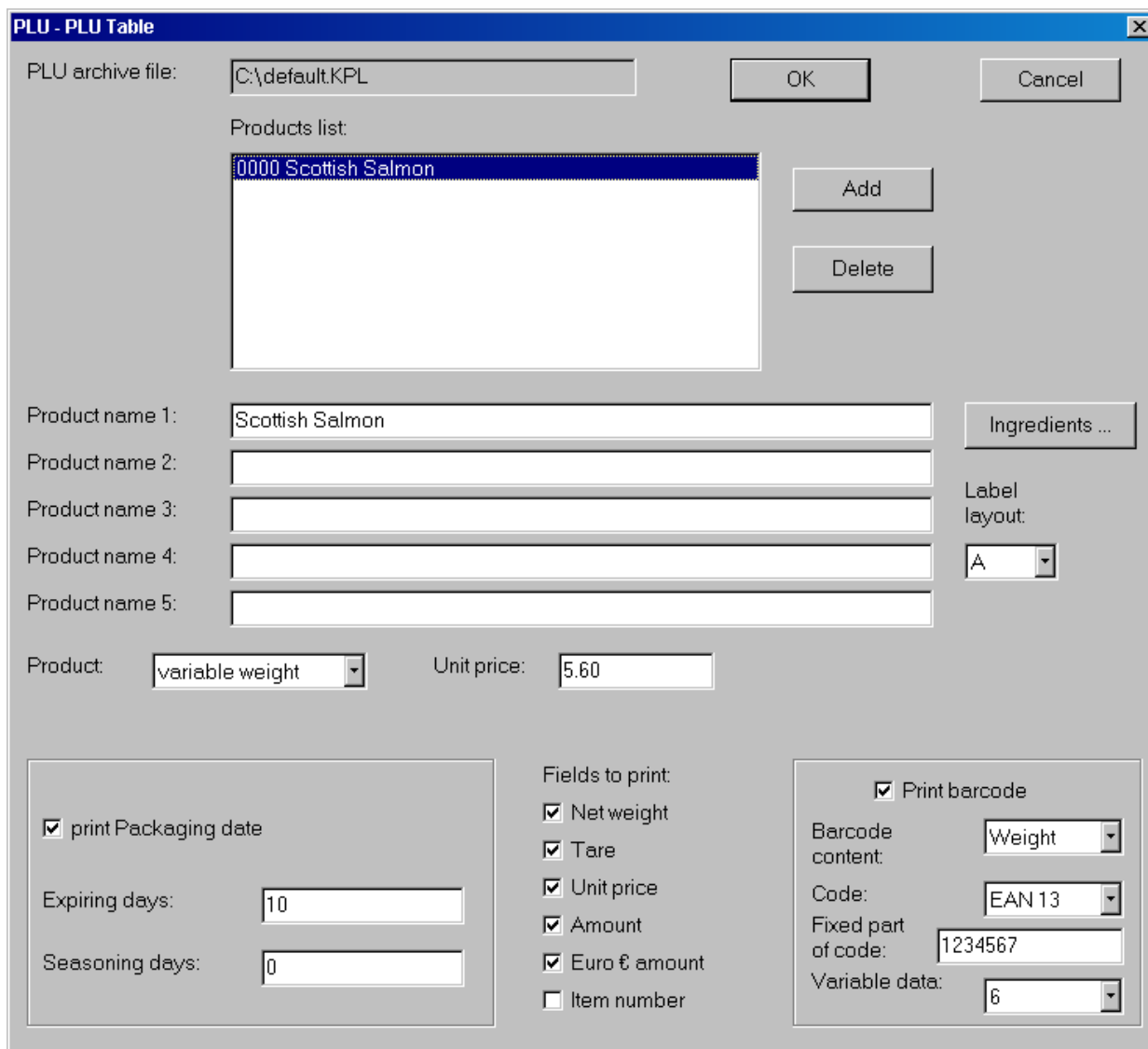

PLU - PLU Table

PLU archive file: C:\default.KPL OK Cancel

Products list:

0000 Scottish Salmon Add Delete

Product name 1: Scottish Salmon Ingredients ...

Product name 2:

Product name 3:

Product name 4:

Product name 5:

Label layout: A

Product: variable weight Unit price: 5.60

print Packaging date

Expiring days: 10

Seasoning days: 0

Fields to print:

Net weight

Tare

Unit price

Amount

Euro € amount

Item number

Print barcode

Barcode content: Weight

Code: EAN 13

Fixed part of code: 1234567

Variable data: 6

Pic. 9 ETIK: PLU table

This section let you create all products (PLU) you need, giving you the opportunity to program, for each of them, the next parameters:

1. Descriptions # 1, 2, 3, 4 and 5
2. Type of product: fixed weight or variable weight
3. Unit Price and Amount
4. Seasoning days
5. Expiring days
6. Barcode composing rules
7. Ingredients tied to product
8. Label layout activated by each product

It is possible to decide, for each product, which variable field will have to be printed by choosing them into “Fields to print:” list.

Creating new PLU

To create new PLUs you have to insert data into text boxes (where needed). When you finish data inserting click on *Add* button.

It may be easy to create a new PLU starting from an already existing PLU. To do so you must select from list the PLU you want to start from, modify its needed fields and click on *Add* button.

Modifying an existing PLU

Click on existing PLU into list and modify all values you have to change. Your changes will be saved when you select another PLU or when you click on *OK* button to quit.

CH. 5: STORING DATA INTO PRINTER

For this all chapter we suppose printer is connected via serial cable to PC.

5.1 VERIFYING PRINTER-PC SERIAL CONNECTION

Turn on printer and wait for the next message on display:

Witty 2000k
Ready !

Run ETIK program on PC, then click on “File – Printer Setup...” (or press F2 key on PC keyboard) to open next window:

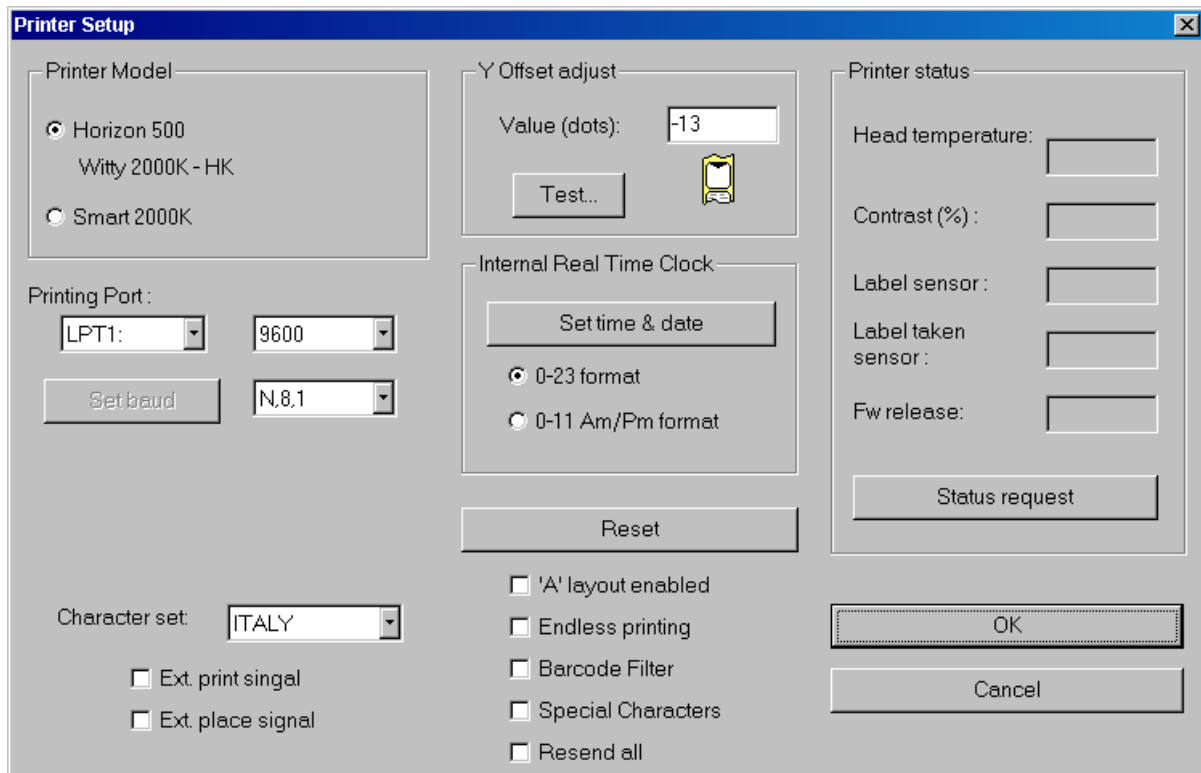

Pic. 10 ETIK: Verifying serial connection

Select the printing port you're going to use on PC.

If you have to use a serial port, choose its parameters too: they must be set as those you see printed on printer test label. You can have a test label by pressing PRINT button on printer keyboard just after having turned it on.

The factory serial parameters are: 9600, N, 8, 1.

Once all serial parameters are set, click on *Status request* button to check connection is correct and wait for a while. If all is good you'll see some values appearing into five text boxes above *Status request* button.

If there's no answer from printer, check serial parameters on PC and printer are the same, or try to change the serial cable.

When this test will give a correct answer, click on *OK* button to quit.

5.2 USING AN INTERNAL PLU LABEL

ETIK contains three labels ready for merceologic use. They are:

- Products label
- Partial and General Totals label
- Grand Total label

To open and use the Products label click on “*PLU – Build PLU label*”.

To open and use the Partial and General Total label click “*PLU – Build PARTIAL TOTAL label*”.

To open and use the Grand Total label click “*PLU – Build GRAND TOTAL label*”.

All these labels contain the correct sequence of variable fields needed for merceologic use.

You cannot change all their parameters: for example you cannot erase the variable fields, because they are indispensable for the correct printer operations.

5.3 TRANSMISSION AND STORING OF DATA TO PRINTER

Be sure printer works in programming mode, that is display is showing:

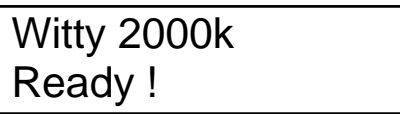

Witty 2000k
Ready !

Before transmitting data to printer you must open all labels you need at a time and you must compile the PLU table, the Ingredients database and the scale parameters.

Click on “*PLU – Download*” to transmit all data (label layouts + PLU table + ingredients database + scale parameters) to printer.

During programming operations ETIK shows a status window: wait until it has disappeared.

At the end of download printer will save automatically the received data into internal permanent memory (you will see a message on printer display showing this operation); then printer will come back to main programming menu and it will be ready for use.

CH. 6: MAINTENANCE

When printer has to stay some time without working (for example during the night pause or holidays periods) keep on mind the following suggestions:

- Turn printer off
- Lift up the printhead (see Picture #3)

6.1 PRINthead CLEANING

1. Turn the power off
2. Wait until thermal head cools down
3. Lift up the print head by using the lever on position 25c (see picture #3)
4. Remove labels roll
5. Moisten a cotton cloth with denatured alcohol
6. Polish the below side to remove incidental adhesive traces or parts of labels
7. Wait until all is dry before use

WARNING: for cleaning never use hard tools as this may damage the print head.

6.2 CLEANING OF RUBBER FEEDING ROLL

1. Turn the power off
2. Wait until thermal head cools down
3. Lift up the print head by using the lever on position 25c (see picture #3)
4. Remove labels roll
5. Moisten a cotton cloth with alcoholic detergents
6. Rub roll in all its length and circumference to remove adhesive traces or parts of labels
7. Wait until all is dry before use

6.3 CLEANING OF PHOTSENSORS

With a soft brush remove dust from windows of photosensors, to avoid errors during reading of transparency of labels and silicon support.

6.4 CLEANING OF METALLIC AND PLASTIC PARTS

Use a soft cloth with water-based detergent (weak).

6.5 CLEANING OF ADHESIVE TRACES OR PARTS OF LABELS

Use alcoholic detergents. Be careful the liquid does not drip on the electronic compartment.

CH. 7: FREQUENTLY ASKED PROBLEMS

7.1 THERE'S NO LABELS FEEDING

Printer could be in one of following conditions:

1 Display (Pic. 1 – #100) is OFF

Check:

- Power cable is connected and there is voltage on the line
- Main switch on the rear printer panel (Pic. 2 – #103) is ON
- Two fuses (Pic. 2 – #6) work correctly

2 Display is ON and it shows message “WARNING END OF PAPER”

Check:

- Labels roll is not finished
- Paper is correctly put under photosensor (Pic. 3 – #10)

3 Display is ON and it shows “WARNING HEAD OVERHEATING”

- Head temperature controller went on: printer stops all operations until print head temperature has fallen again to normal values

7.2 WRONG LABEL ALIGNEMENT

Check and be sure that:

- Print head is in working position (Pic. 3 – #25a)
- Paper is correctly put under photosensor (Pic. 3 – #10)
- Silicon support and/or backing paper is correctly rewound (Pic. 3 – #15)
- Pressure clip (Pic. 3 – #33) is positioned between centre and outer right side of the label
- Guide arm (Pic. 3 – #32) is tightly pushed against the side of the label roll
- Printer is working in label mode and not in continuous mode
- Start-up with pushed print button procedure has been executed (paragraph #1.6)

7.3 PAPER SLIDES TO RIGHT SIDE

Check and be sure that:

- Pressure clip (Pic. 3 – #33) is positioned between centre and outer right side of the label
- Guide arm (Pic. 3 – #32) is tightly pushed against the side of the label roll

7.4 PRINTING DEFECTS

- Check that printing trimmer is correctly set
- If needed, clean the print head (paragraph #6.1)

7.5 BLANKS LABEL EMITTED

- Check print head is in working position (Pic. 3 – #25a)
- Check that printing trimmer is correctly set
- Check the state of fuse 8AT (Pic. 2 – #9) on the rear panel
- Check head flat connector is correctly connected with mechanical key up
- If you use the ink ribbon, check its inked side is placed in contact with labels

7.6 PRINTING TRIMMER NOT CORRECT

If your printings are too light, or on the contrary too dark, see paragraph #2.7 to change trimmer intensity

7.7 LABELS ARE NOT PEELED OFF

This kind of trouble can appear only when printer works in dispensing mode.

Check the next points:

- print head is in working position (Pic. 3 – #25a)
- label adhesive respects the specifications (see paragraph #1.7)