

# THERMAL & THERMAL TRANSFER LABEL PRINTERS

models

**smart 630 & smart 830**

## USER MANUAL

*starting from S/N 4849 S*

**Ditalora**

**Italora S.r.L. Largo Guastalla 7 - 20082 Binasco - (Milano) - Italy**  
phone ++39.02.90092074 - fax ++39.02.9055461

**<http://www.italora.it>**  
e-mail: **[sales@italora.it](mailto:sales@italora.it)**

## CONTENTS

1. GENERAL DESCRIPTION .....	3
2. TECHNICAL SPECIFICATIONS.....	3
3. UNPACKING .....	4
4. EXTERNAL DESCRIPTION.....	4
5. MAIN COMPARTMENT DESCRIPTION.....	4
6. INCOMING INSPECTION .....	5
6.1. LABEL FORMAT SET UP PROCEDURE .....	5
7. PRINTING MEDIA DESCRIPTION .....	6
7.1 PAPER SPECIFICATIONS.....	6
7.2. THERMAL RIBBON SPECIFICATIONS .....	6
8. THERMAL RIBBON AND LABEL ROLL REPLACEMENT.....	6
8.1. THERMAL RIBBON REPLACEMENT (TT MODELS).....	6
8.2. LABEL ROLL REPLACEMENT.....	6
8.2.1. DISPENSING MODE.....	6
8.2.2. STRIP FORM MODE.....	6
8.2.3. REWINDING MODE.....	7
9. CONNECTION TO HOST COMPUTER.....	7
9.1 SERIAL INTERFACE.....	7
9.2 PARALLEL CENTRONICS INTERFACE .....	7
10. DIP SWITCHES FACTORY SETTING .....	8
11. MAINTENANCE.....	8
11.1. CLEANING .....	8
12. TROUBLE SHOOTING .....	8
12.1. NO LABELS FEEDING.....	8
12.2. INCORRECT LABEL ALIGNMENT.....	9
12.3. PAPER SLIDES TO RIGHT SIDE .....	9
12.4. PRINTING WITH PATCHES MISSING.....	9
12.5. BLANK LABELS .....	9
12.6. POOR PRINTING CONTRAST .....	9
12.7. LABELS ARE NOT CORRECTLY PEELED OFF .....	9
13. HARDWARE NOTES .....	9
13.1. HOW TO CHECK ELECTRONIC BOARDS .....	9
13.2. ELECTRONIC BOARDS REPLACEMENT.....	9
13.3. PRINT HEAD PROTECTION FUSE REPLACEMENT.....	9
13.4. THERMAL PRINT HEAD REPLACEMENT .....	10
13.4.1. <b>smart 630</b> , 6 dots resolution .....	10
13.4.2. <b>smart 830</b> , 8 dots resolution .....	10
13.5. DRIVE BELT REPLACEMENT.....	10
14. PICTURES .....	11
15. PART LIST AND RELEVANT PICTURES.....	17

Features and specifications are subject to change without notice

# smart 630 & smart 830

## GRAPHIC LABEL PRINTERS

### 1. GENERAL DESCRIPTION

These units offer an accurate and high quality printing moreover a formatting capability of 26 layouts in EEPROM. They can operate in dispensing mode, because of the inside mechanism for peeling and rewinding, or in strip form.

Resident Bar Codes are dispensed at high

speed and the eleven character generators with eighty magnifications give a wide range of fonts.

The inside label unwind holder offers an autonomy of 1500 labels (106 x 70 mm), the modular design of these printers offers an easy service as well for electronic boards as for mechanics maintenance.

### 2. TECHNICAL SPECIFICATIONS

Starting from serial number 1500S, printers of this family have obtained the IMQ approval according to European Standard EN 60950.

#### PRINTING

Method: Direct Thermal and Thermal Transfer  
Resolution: 6 dots/mm, (**smart 630**)  
8 dots/mm, (**smart 830**)  
Print width: 105.6 mm (**smart 630**)  
102.0 mm (**smart 830**)  
Print speed: up to 150 mm/s  
X/Y positioning of texts and bar codes  
Texts and bar codes printed in four orthogonal directions  
Lines, boxes, shadow and reverse printing  
Graphic and logos: bit image mode  
Bar Codes: EAN8, EAN13, 2/5, 2/5 I, 3/9, 2/7, DUN-14/16, UPC-A, UPC-B, UPC-E, CODE 128, EAN 128  
Automatic Check Digit computation  
Wide/narrow ratio full programmable  
Half, standard and double density  
Height programmable  
Suppression of human readable characters  
Batch printing: up to 9999 labels  
Layouts: 26 programmable in EEPROM  
Up to 10 protection levels for variable data printing  
4 up/down 16 digits counters  
Real Time Clock  
Black intensity adjustable via software  
Print button for last label repeating  
THERMAL HEAD TEMPERATURE CONTROL  
DATA TRANSFER INTERFACE  
RS232 : serial parameters settable by dip switches  
RS485 : on request  
PARALLEL CENTRONICS : on request  
HANDSHAKE PROTOCOL  
SW : XON/XOFF  
HW : DTR  
DATA TRANSMISSION  
ASCII format  
CHARACTER GENERATORS  
Micro (fixed matrix) 5x5  
Standard (fixed matrix) 7x5  
Draft (fixed matrix) 8x13  
Big (proportional) 32  
New Century (proportional) 45  
Title (fixed matrix) 88x88  
Compact (proportional) 19  
Olaf (fixed matrix) 32x48  
Century (proportional) 31  
Arial (proportional) 49  
Bookman (proportional) 63  
Magnifications 9x9

#### CHARACTER SIZES

**smart 630** 0.82 x 0.82 mm minimum  
132.00 x 132.00 mm maximum  
**smart 830** 0.62 x 0.66 mm minimum  
99.00 x 105.30 mm maximum

#### PERMANENT MEMORY

32K bytes, 20 years data retention

#### DETECTORS

End of paper and feeding synchronism  
End of thermal ribbon (TT models)

#### PRINT MEDIA

Labels, tags and continuous paper

#### LABEL SIZES

Width: 30 mm min., 110 mm max  
Length: 10 mm min.  
341 mm max **smart 630**  
209 mm max **smart 830**

Key: width min.: 2 mm  
depth min.: 7 mm starting 2 mm min.  
from the inner edge

#### ROLL SIZES

Width: 30 mm min., 110 mm max  
Outer diameter: 150 mm max  
Core diameter: 38 mm min.

#### THERMAL RIBBON (TT models)

Base polyester film

Outer diameter: 58 mm max, length 220 meters  
Width: 35 mm min., 110 mm max  
Core diameter: 25.4 mm

#### PRINTER DIMENSIONS

Height: 200 mm; Depth: 440 mm  
Length: 235 mm; Weight: 17 Kg

#### POWER REQUIREMENTS

Voltage: 115/230/240 Vac; 50-60 Hz  
on request 110 Vac

#### ENVIRONMENT

Operating temperature: 0°/ 40° C  
Storage temperature: -20°/60° C  
Humidity: 10% - 95% non-condensing

#### OPTIONS

Label taken sensor  
Guillotine  
Pick & Place interface (optoisolated)  
lines: one INPUT, two OUTPUT)  
RS485 Interface

### 3. UNPACKING

Open the box and check the content : **italora** printer model **smart 630** or **smart 830**

- b) power cable
- c) roll of labels

- d) roll of thermal ribbon (TT model only)
- e) printing tests
- f) serial cable RS232
- g) CD Rom with manuals and Etik Light

### 4. EXTERNAL DESCRIPTION

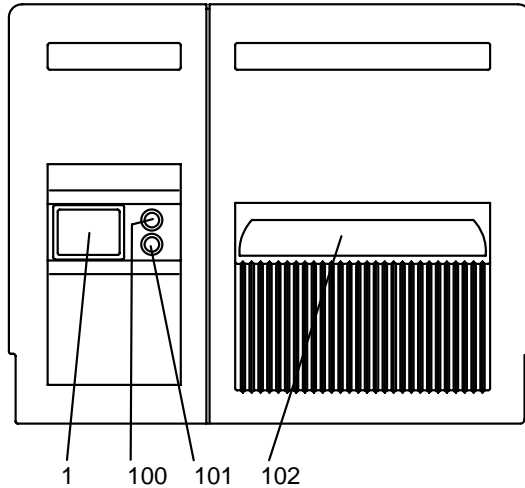

PICTURE 3

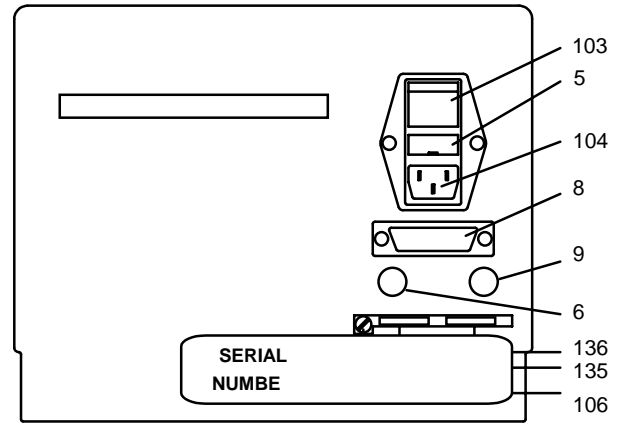

PICTURE 4

- 1: manual printing push button
- 100: **red led** => lit at POWER ON
- 101: **status led** =>
  - **lit green:** ON-LINE
  - **blinking green:** end of paper
  - **lit yellow:** syntax error (push printing button to restart)
  - **blinking yellow:** head temperature control active
  - **alternate green/yellow blinking:** end of ribbon (TT models only)
- 102 label output

- 5: 2 fuses 2AT (main)
- 6: 1 fuse 1.6AT (logic)
- 8: I/O connector
- 9: fuse 8AT (thermal head)
- 103: main switch
- 104: power cord plug
- 106 trimmer for black intensity fine adjust
  - clockwise = more intensity
  - anticlockwise = less intensity
- 135 dip switch n°1
- 136 dip switch n°2

### 5. MAIN COMPARTMENT DESCRIPTION

(see following picture)

- 10 - photosensor for end of roll and label synchronisation
- 15 - rewinding shaft with adjusting clutch
- 18 - print head position fine adjustment
- 21 - rubber feeding roll
- 23 - print head assembly pressure spring
- 25 - lock / unlock lever
  - 25a - working position
  - 25b - open position
  - 25c - cleaning position
- 29 - thermal ribbon rewinder (TT model)
- 30 - thermal ribbon stock (TT model)
- 32 - label guide arm
- 33 - pressure clip
- 35 - front cover
- 45 - label unwind holder
- 48 - photosensor for end of thermal ribbon (TT model)
- 105 - print head assembly

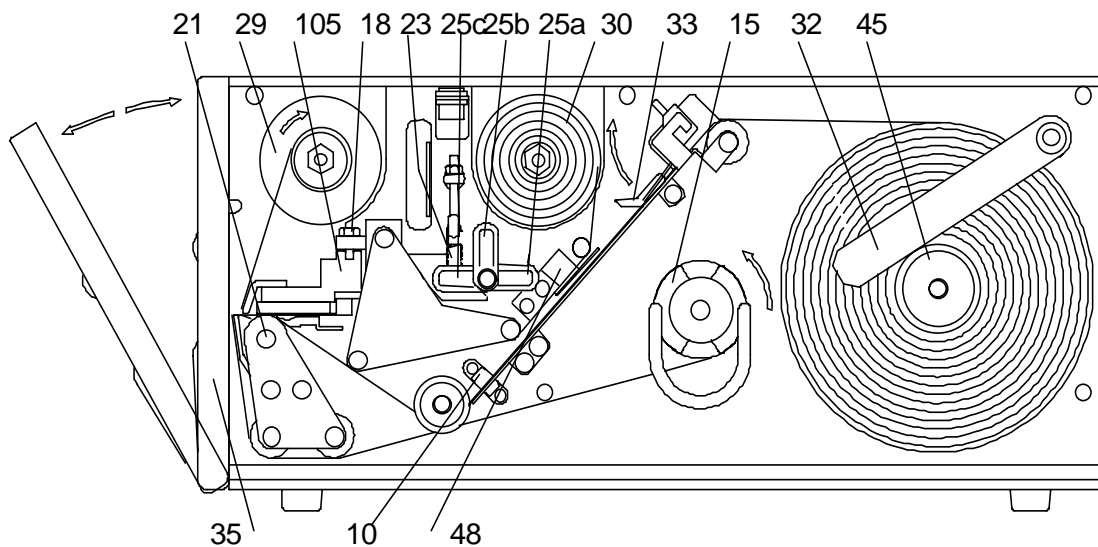

PICTURE 6

## 6. INCOMING INSPECTION

- \* Open the main compartment
- \* Check the presence of the label roll and of the thermal ribbon roll (TT model)
- \* Check the correct pinout of the serial I/O Cannon 25 pins female connector (or of the Centronics 36 pins female connector) and connect the printer to the computer .
- \* For further details see chapter "Connection to Host Computer".
- \* Check the voltage on the name plate next to the power receptacle.
- \* Connect the power cable to a grounded power line
- \* Lift the printhead down by rotating the lever #25a.
- \* Switch the main switch on (rear panel)  
RED and GREEN leds ON mean operating conditions.
- \* Push the PRINT BUTTON, you will get a printing test with the EPROM release information.
- \* Sending data from the computer you will get the first printing.
- \* Push the PRINT BUTTON to get the last printing again; the printer keeps the information of the last printing until next data arrive.

NOTE: **Printer retains the label length and the backing paper transparency in permanent memory. In case of change of print media see the following paragraph.**

### 6.1. LABEL FORMAT SET UP PROCEDURE

(see pictures 7 and 8)

The printer retains the label length and the backing paper transparency in permanent memory. **If changing label format or print media type** you have to use the following procedure to update the values:

- 1 - Switch the printer off.
- 2 - Lift the printing head up by rotating lever #25b.
- 3 - Thread the web between the feed roller and the printig head #21,105.
- 4 - Check web has been rightly positioned under the label photosensor #10.
- 5 - Lift the printing head down by rotating the lever #25a.
- 6 - Switch the printer on while pushing the print button.
- 7 - Printer ejects some labels (depending on their length) and stores the values of the media.
- 8 - Release the print button.
- 9 - The green led lit and the printer is ready to work.

**For further information about media options see chapter 7 and the paragraph "Labels, tags and continuous media printing" of the PROGRAMMING MANUAL.**

## 7. PRINTING MEDIA DESCRIPTION

### 7.1 PAPER SPECIFICATIONS

- White coated glossy printing paper
- weight: 65 ÷ 90 g/mq (ISO536)
  - caliper: 0,075 ÷ 0,083 mm (ISO534)

#### ADHESIVE SPECIFICATIONS

- peel adhesion(90° C): 430 N/m
- service temperature: -20° C ÷ + 70° C

#### LINER SPECIFICATIONS

- BG 40 brown, supercalendered glassine
- weight: 65g/mq (ISO536)
- caliper: 0.057 mm (ISO534)
- transparency: 45%

#### TAGS AND CONTINUOUS STRIPS

- weight: 200 g/mq max

#### SUGGESTED MODELS

- Fasson Fasthermal NT
- Kanzaki KPT 86-H
- Fasson Fastransfer MP - S470 (TT models)
- Fasson Fastransfer Extra - S470 (TT models)

#### LABEL AND TAGS DIMENSIONS

See Chapter 2

### 7.2. THERMAL RIBBON SPECIFICATIONS

- film thickness 4.5 ÷ 6 micron
- core diameter: 25.4 mm
- outer diameter: 58 mm max
- width: 35 mm min/ 110 mm max
- length: about 220 meters (58 mm DIA. max)

- ink coating outside

#### SUGGESTED MODELS

- TOIKO C 250 (matt paper)
- TOIKO CR 150 (glossy paper and polypropylene)
- TOIKO R 300 (plastic media)

#### STORAGE

Keep labels and ribbons in a dry place at temperature not over 40° C and not exposed to direct sun light.

## 8. THERMAL RIBBON AND LABEL ROLL REPLACEMENT

### 8.1. THERMAL RIBBON REPLACEMENT (TT MODELS)

(see picture 7)

Open side of printer.

Remove the used roll. Remove the core #47 from the shaft and put it on the rewinder #29.

By rotating the lever #25b, lift the printing head #105 from the feed roller #21, setting the movement of the ribbon free.

Slide new ribbon #43 onto shaft and thread it under the ribbon photosensor #48 and the threaders #108,107 and 37 and up round to the rewinder #29. Attach the ribbon leader with label/tape to core #47. Return head lever to closed position #25a. Close side of printer.

### 8.2. LABEL ROLL REPLACEMENT

In case of changing of label format or printing media type, remember to follow the "Label format set up procedure" shown on paragraph 6.1.

#### 8.2.1. DISPENSING MODE

(see picture 8)

Open side of printer.

Remove the empty label roll.

Lift guide arm #32.

Insert new label roll onto roller #45

Bring the guide arm #32 down and push it tightly against the side of the label roll.

By rotating the lever #25b, lift the printing head #105 from the feed roller #21, setting the movement of labels and ribbon free.

Remove clip #28 from the rewinding shaft #15.

Remove backing paper from the rewinding shaft.

Remove the first 50 centimetres from liner of the new roll labels.

Hold pressure clip #33 up and feed the liner through the path, slide it on the rewinder unit #15 and fasten it with the clip holder #28.

Turn the rewinder to stretch the paper.

Turn head lever back to closed position #25a.

Check paper has been rightly positioned under the label photosensor #10.

Check pressure clip #33 has been positioned between centre and outer side of the label.

Close side of printer.

#### 8.2.2. STRIP FORM MODE

(see picture 9)

Open side of printer.

Remove the empty label roll.

Lift up the guide arm #32.

Insert new label roll onto roller #45

Bring the guide arm #32 down and push it tightly against the side of the label roll.

By rotating the lever #25b, lift the printing head #105 from the feed roller #21, setting the movement of labels and ribbon free.

Hold pressure clip #33 up and feed the paper through the path.

Turn head lever back to closed position #25a.

Check paper has been rightly positioned under the label photosensor #10.

Check pressure clip #33 has been positioned between centre and outer side of the label.

Close side of printer.

### 8.2.3. REWINDING MODE

(see pictures 10 and 11)

Is necessary to rewind printed labels inside to remove the plate #20, turning the screws #139,140 out.

Open side of printer.

Remove the empty label roll.

Lift guide arm #32.

Insert new label roll onto roller #45

Bring the guide arm #32 down and push it tightly against the side of the label roll.

By rotating the lever #25b, lift the printing head #105 from the feed roller #21, setting the movement of labels and ribbon free

Remove clip #28 from the rewinding shaft #15.

Hold pressure clip #33 up and feed the paper through the path, slide it on the rewinder unit #15 and fasten it with the clip holder #28.

Turn the rewinder to stretch the paper.

Turn head lever back to closed position #25a.

Check paper has been rightly positioned under the label photosensor #10.

Check pressure clip #33 has been positioned between centre and outer side of the label.

Close side of printer.

## 9. CONNECTION TO HOST COMPUTER

### 9.1 SERIAL INTERFACE

**smart 630** and **smart 830** printers have a RS232 hardware interface (RS485 on request). Provided on board connector is a Cannon 25 pins "DB" female cabled as shown in the following pictures.

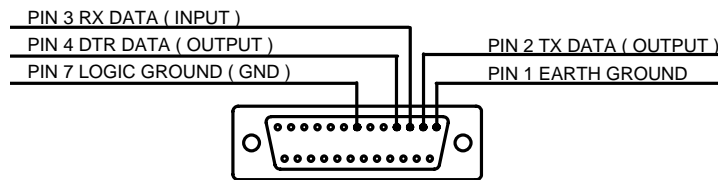

#### COMPUTER CONNECTOR WITH 9 PINS

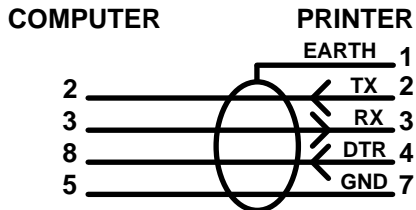

COMPUTER CONNECTOR:

- using sw protocol XON/XOFF:  
short together PINS 7-8 and 1-4-6.
- using hw protocol DTR:  
short together PINS 1-4-6.

#### COMPUTER CONNECTOR WITH 25 PIN

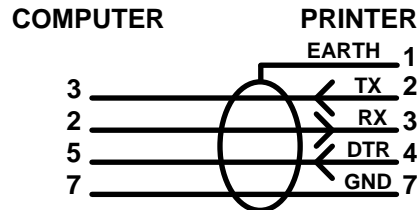

COMPUTER CONNECTOR:

- using sw protocol XON/XOFF:  
short together PINS 4-5 and 6-8-20.
- using hw protocol DTR:  
short together PINS 6-8-20.

### 9.2 PARALLEL CENTRONICS INTERFACE

Provided on board connector is a 36 pins female cabled as shown in following picture.

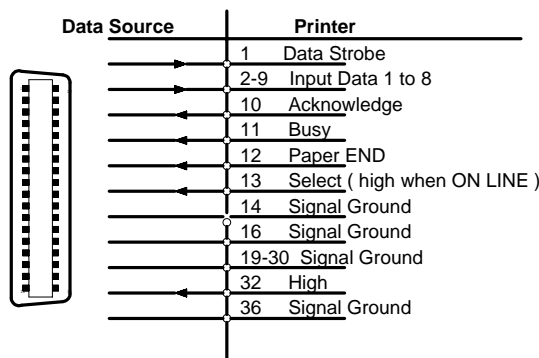

## 10. DIP SWITCHES FACTORY SETTING

Referring to pictures 4 and 21, dip switches factory setting for **smart 630** & **smart 830** family is shown in following tables (rear view, from left to right). For more details see also "**PROGRAMMING MANUAL**".

- **Thermal Transfer mechanisms.**

SERIAL VERSION

SW - 1

1	2	3	4	5	6	7	8
-	-	OFF	OFF	-	-	OFF	OFF
ON	ON	-	-	ON	ON	-	-

SW - 2

1	2	3	4	5	6	7	8
OFF	OFF	OFF	OFF	OFF	OFF	OFF	OFF
-	-	-	-	-	-	-	-

PARALLEL CENTRONICS VERSION

SW - 1

1	2	3	4	5	6	7	8
OFF	OFF	OFF	OFF	OFF	-	OFF	OFF
-	-	-	-	-	ON	-	-

SW - 2

1	2	3	4	5	6	7	8
OFF	OFF	OFF	OFF	OFF	OFF	OFF	OFF
-	-	-	-	-	-	-	-

- **Direct Thermal Only mechanisms.**

SERIAL VERSION

SW - 1

1	2	3	4	5	6	7	8
-	-	OFF	OFF	-	OFF	OFF	OFF
ON	ON	-	-	ON	-	-	-

SW - 2

1	2	3	4	5	6	7	8
OFF	OFF	OFF	OFF	OFF	OFF	OFF	OFF
-	-	-	-	-	-	-	-

PARALLEL CENTRONICS VERSION

SW - 1

1	2	3	4	5	6	7	8
OFF	OFF	OFF	OFF	OFF	OFF	OFF	OFF
-	-	-	-	-	-	-	-

SW - 2

1	2	3	4	5	6	7	8
OFF	OFF	OFF	OFF	OFF	OFF	OFF	OFF
-	-	-	-	-	-	-	-

## 11. MAINTENANCE

WHEN NOT IN USE:

- SWITCH OFF POWER
- ALWAYS LIFT UP THE PRINTER HEAD

### 11.1. CLEANING

#### Print Head

- Turn the power off.
- Wait until thermal head cools down.
- Lift the print head by using the lever on position 25c
- Remove labels and thermal ribbon.

- Moisten a cotton cloth with denatured alcohol.
- Polish the below side to remove incidental adhesive traces or parts of labels
- Wait until dry before use

**WARNING: never use hard tools as this may damage the print head.**

**Rubber feeding roll:** use alcoholic detergents.

**Photosensor:** use a soft brush.

**Metallic and plastic parts:** use a soft cloth with water-based detergent (weak).

**Removing adhesive traces or parts of labels:** use alcoholic detergents. Be careful the liquid does not drip on the electronic compartment.

## 12. TROUBLE SHOOTING

### 12.1. NO LABELS FEEDING

Four situations may occur.

a) RED led is OFF, check (pict.3,#100):

- main voltage
- main switch (pict.4,#103) ON.
- main connector (pict.4,#104) plugged in
- main fuses (pict.4,#6) intact.

b) RED led is ON, STATUS led is BLINKING GREEN,

- check:
- label roll is not used up.
  - paper position under the photosensor (pict.8,#10)

c) RED led is ON, STATUS led is BLINKING

- alternately GREEN and YELLOW, check:
- thermal ribbon is not used up (TT models).
  - thermal ribbon position under the photosensor (pict.7,#48) (TT models).

d) RED led is ON, STATUS led is BLINKING YELLOW:

- head temperature control active, printer stops until temperature has fallen to normal values.

## 12.2. INCORRECT LABEL ALIGNMENT

Make sure that:

- print head is closed (pict.6,#25a)
- paper position under the photosensor (pict.8,#10)
- backing paper is correctly rewound (pict.6,#15)
- pressure clip (pict.6,#33) is positioned

between centre and outer side of the label.

- guide arm (pict.6,#32) is tightly pushed against the side of the label roll.

See also "Label format set up procedure" paragraph 6.1

## 12.3. PAPER SLIDES TO RIGHT SIDE

Check whether:

- pressure clip (pict.6,#33) is positioned between centre and outer side of the label.

- guide arm (pict.6,#32) is closely positioned against the side of the label roll.

## 12.4. PRINTING WITH PATCHES MISSING

Check whether:

- thermal print head needs cleaning (chapter 11)

AND FOR TT MODELS:

- thermal ribbon unwinds correctly.

- there are creases on the rewound thermal ribbon. If so, turn the nut (pict.7,#110) clockwise, in order to increase the rewinding torque (a quarter of a turn max) while holding the roller (pict.7,#29) still.

## 12.5. BLANK LABELS

Check whether

- the fuse (8AT) on the back panel has blown
- the print head connector is correctly plugged in

(pict.13,#112) with polarity key up.

- thermal ribbon is correctly positioned, opaque surface on the label side (TT models).

## 12.6. POOR PRINTING CONTRAST

- See printer rear panel.
- turn the print head screw (pict.4,#106) for temperature fine adjustment :  
clockwise to make print darker.  
anticlockwise to make print lighter.

Otherwise use the software command ?77& (see Programming Manual)

**BEWARE:** continual high operating temperature of thermal head may reduce its working life and may also fuse the ribbon(TT models).

## 12.7. LABELS ARE NOT CORRECTLY PEELED OFF (DISPENSING MODE)

- Make sure the label adhesive respects the specifications (see chapter 7).
- Turn the nut (pict.16,#41) clockwise, in order to increase the rewinding torque (a turn max) while holding the roller (pict.16,#15) still.

**BEWARE:** excessive torque may cause incorrect labels alignment.

## 13. HARDWARE NOTES

### 13.1. HOW TO CHECK ELECTRONIC BOARDS

- **First unplug the power cable from the printer.**
- open side of printer
- remove the 6 side screws (pict.19,#114,115,116, 119,120,121)
- turn the 2 rear panel screws (pict.18,#117,118) out.
- pull carefully off the electronic cabinet from the printer chassis and unplug the following connectors from CPU board (pict.21).

- Y2 = ribbon photosensor
- Y3 = leds and push button
- Y4 = stepping motor
- Y5 = label photosensor
- Y8 = thermal head (**smart 630**, 6 dots resolution)
- Y9 = thermal head (**smart 830**, 8 dots resolution)
- disconnect the ground cable turning the chassis nut out.

### 13.2. ELECTRONIC BOARDS REPLACEMENT

Unplug the following connectors from the CPU board (pict.21):

- Y10 = power supply
- Y7 = serial interface
- turn the 4 rear panel screws (pict.18,#122,123,124,125) out.

- turn the lock screws (pict.20,#111,113) out and pull out the CPU board (pict.20,#50).
- unplug the fuses connectors and the main switch connector.
- turn the 2 lock screws (pict.20,#126,127) out.
- pull the power supply (pict.20,#13) out.

### 13.3. PRINT HEAD PROTECTION FUSE REPLACEMENT

- Thermal print head is protected by an 8 A timed fuse (pict.4,#9).

## 13.4. THERMAL PRINT HEAD REPLACEMENT

### 13.4.1. smart 630, 6 dots resolution

(see picture 26)

- 1 switch the printer off .
- 2 unplug the flat connector from the print head.
- 3 turn the screws #128 and #129 out.
- 4 lift print head by rotating the lever #25c.
- 5 remove the plate #37 and the print head #26 from the support.
- 6 replace the thermal head and run back steps 5 to 2.

**WARNING: pay attention to plug in correctly the thermal head connector, wrong connection causes irreversible damage to the print head functionality**

### 13.4.2. smart 830, 8 dots resolution

(see picture 27)

- 1 switch the printer off .
- 2 unplug the flat connector #112 from the print head.
- 3 lift print head by rotating the lever #25c..
- 4 turn the screw #130 out.
- 5 remove the adjusting nut #18.
- 6 pull out the print head and dissipater assembly from the pivot pin.
- 7 turn the screw #138 out and remove the print head #26 from the dissipater.
- 8 replace thermal head and run back steps 7 to 2.

**WARNING: pay attention to plug in correctly the thermal head connector, wrong connection causes**

**(pict.13)**

- 7 in case of printing quality problems, loosen the screw #130 and turn slowly the adjusting nut in or out #18, for the best printing quality, finally lock the screw #130.
- 8 in case of creases on the rewound thermal ribbon, loosen the screws #128,129 and adjust the plate #37 in order to obtain a correct parallelism and flatness on the rewound ribbon; finally lock the screws #128,129 (TT models).

**irreversible damage to the print head functionality (pict. 13)**

- 9 in case of printing quality problems, loosen the screw #130 and turn slowly the adjusting nut in or out #18, for the best printing quality, finally lock the screw #130.
- 10 in case of creases on the rewound thermal ribbon, loosen the screws #128,129 and adjust the plate #37 in order to obtain a correct parallelism and flatness on the rewound ribbon; finally lock the screws #128,129 (TT models).

## 13.5. DRIVE BELT REPLACEMENT

(see pictures 28 and 29)

Disassemble the electronic cabinet from the printer chassis as shown in paragraph 14.1, remove the 2 screws #131, 133 and the safeguard plate #134, then

loosen the idler #16. Replace the belt and stretch it by the idler till you get a deflection of 4 to 6 mm when applying a force of 7 N.

# 14. PICTURES

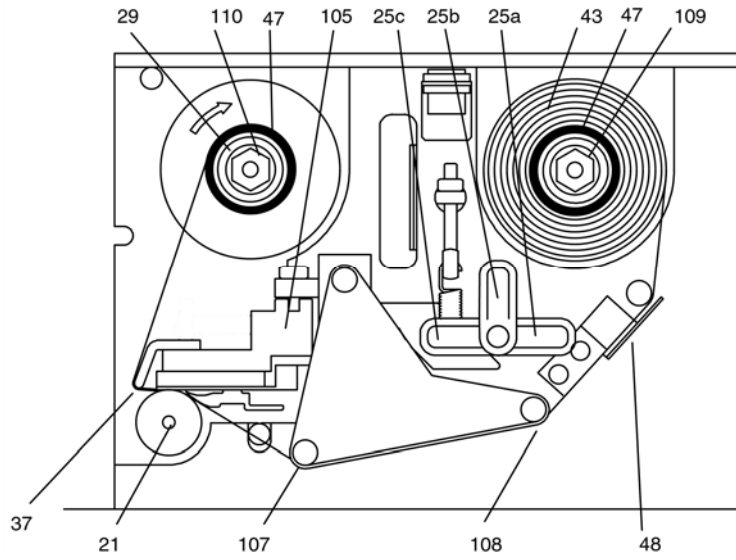

**PICTURE 7**

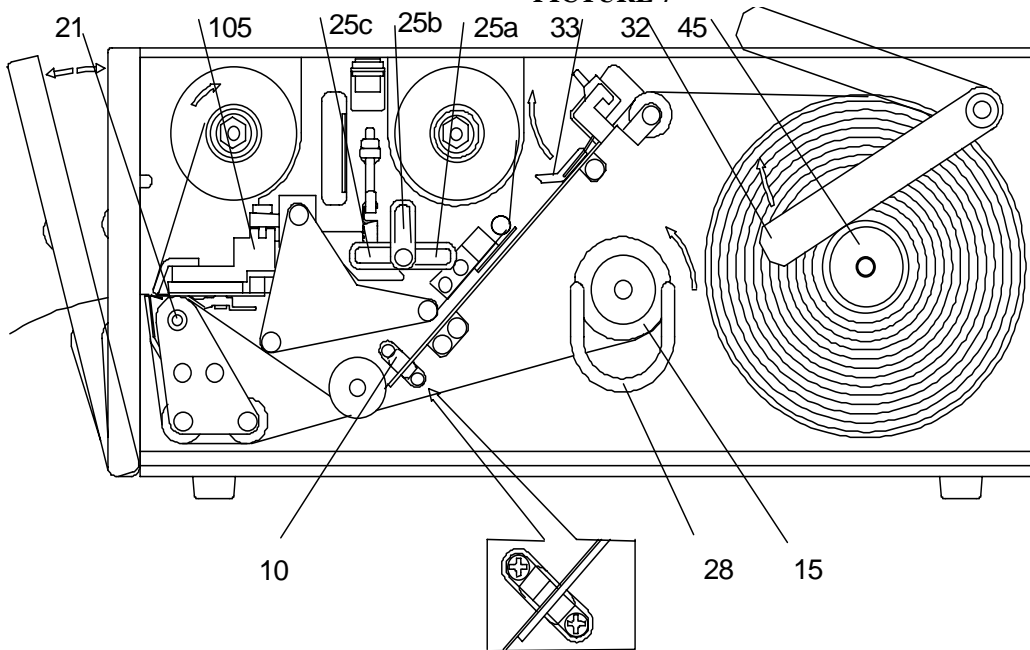

**PICTURE 8**

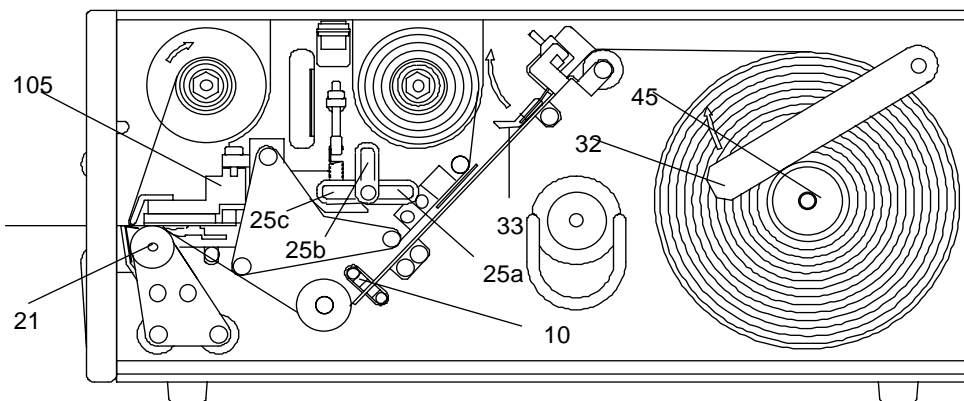

**PICTURE 9**

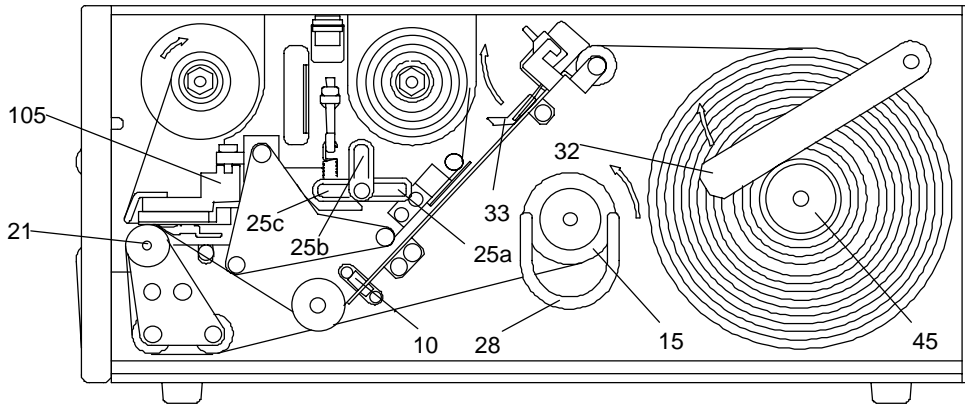

PICTURE 10

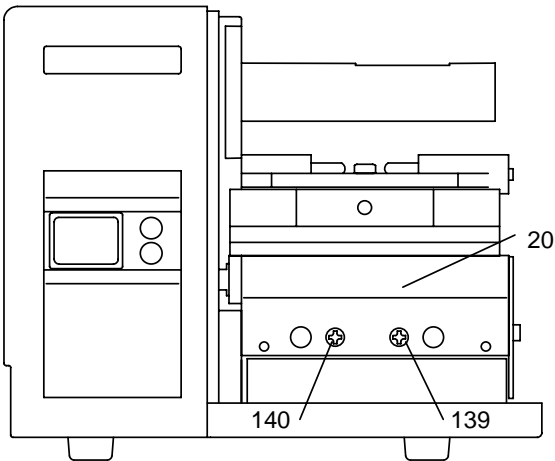

PICTURE 11

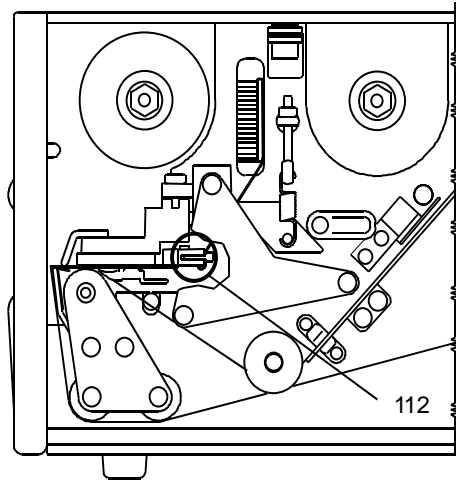

PICTURE 13

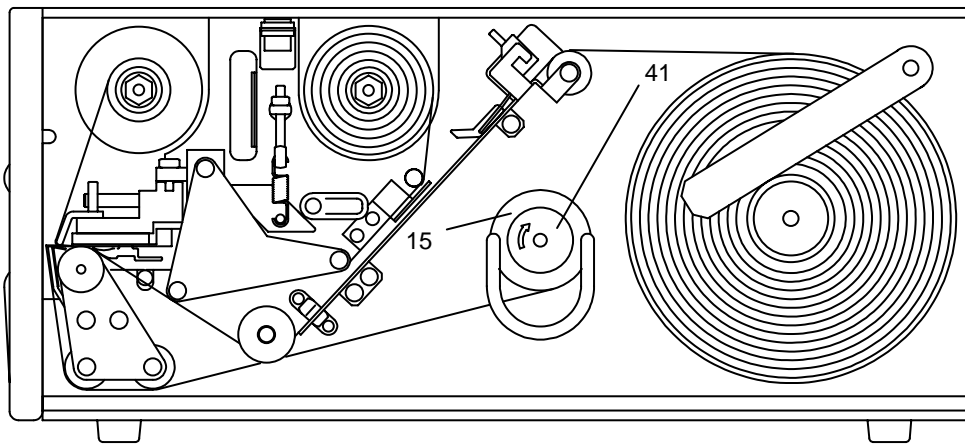

PICTURE 16

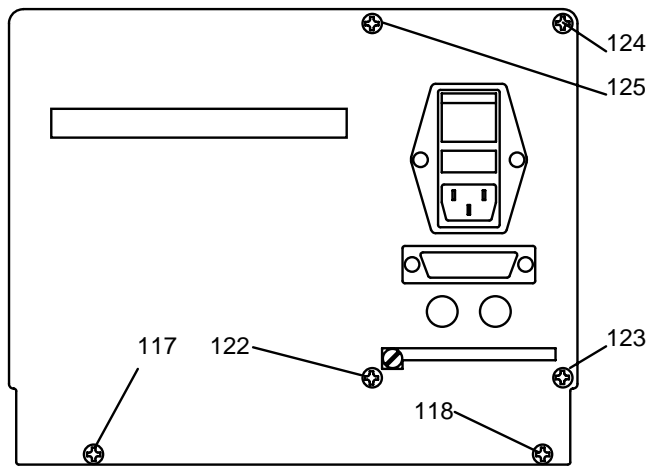

PICTURE 18

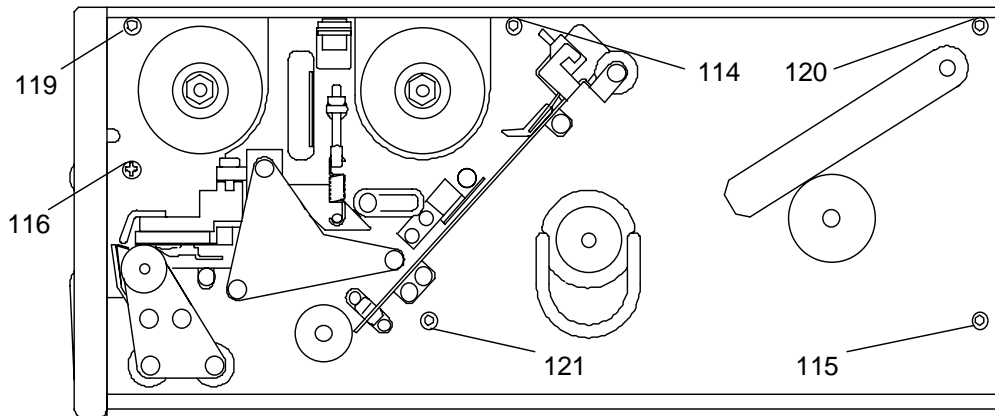

PICTURE 19

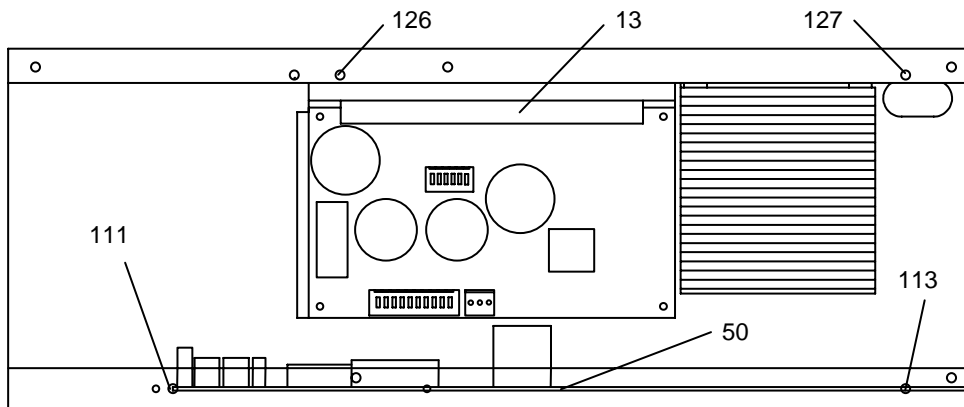

PICTURE 20

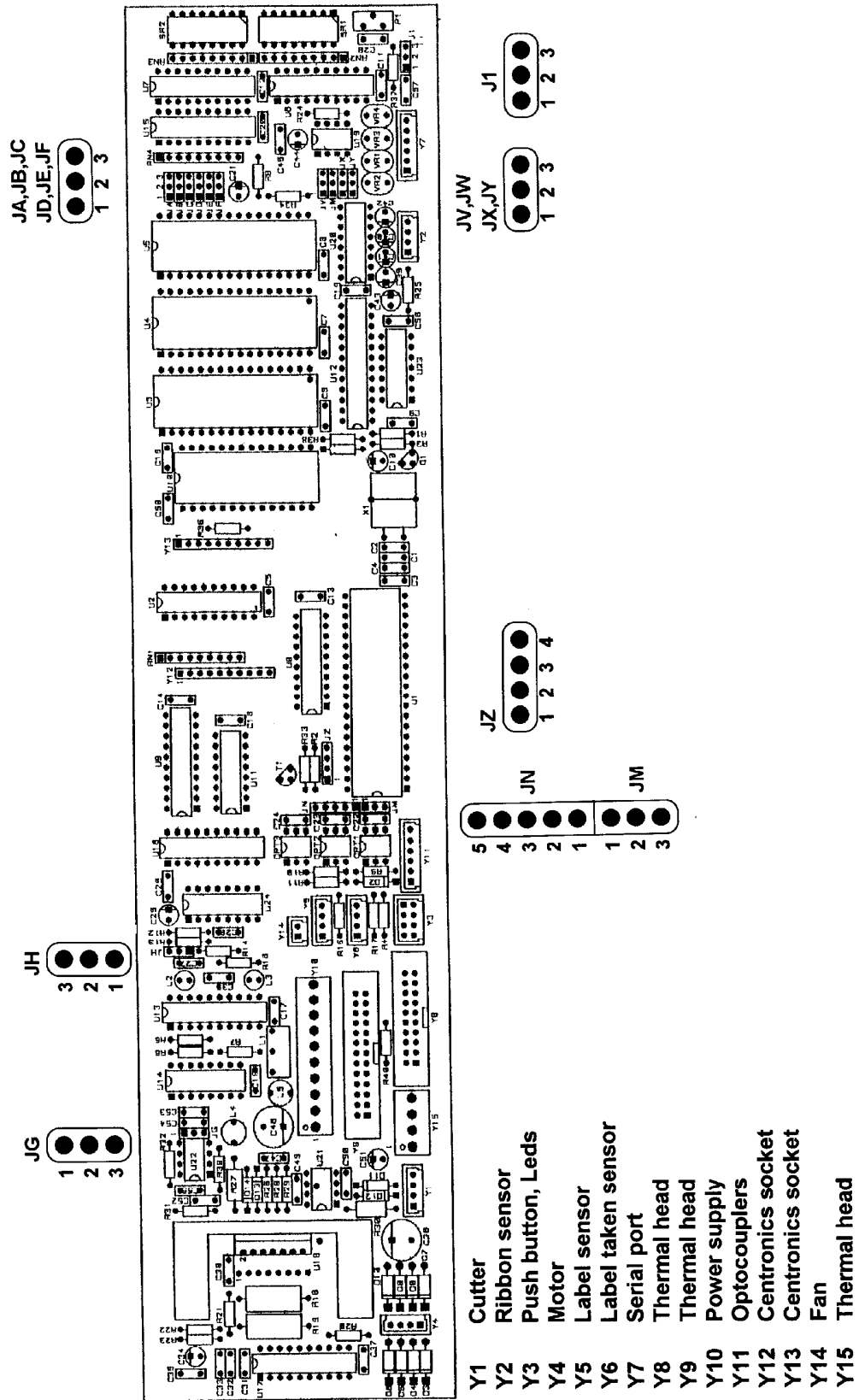

PICTURE 21

LOGIC BOARD - layout

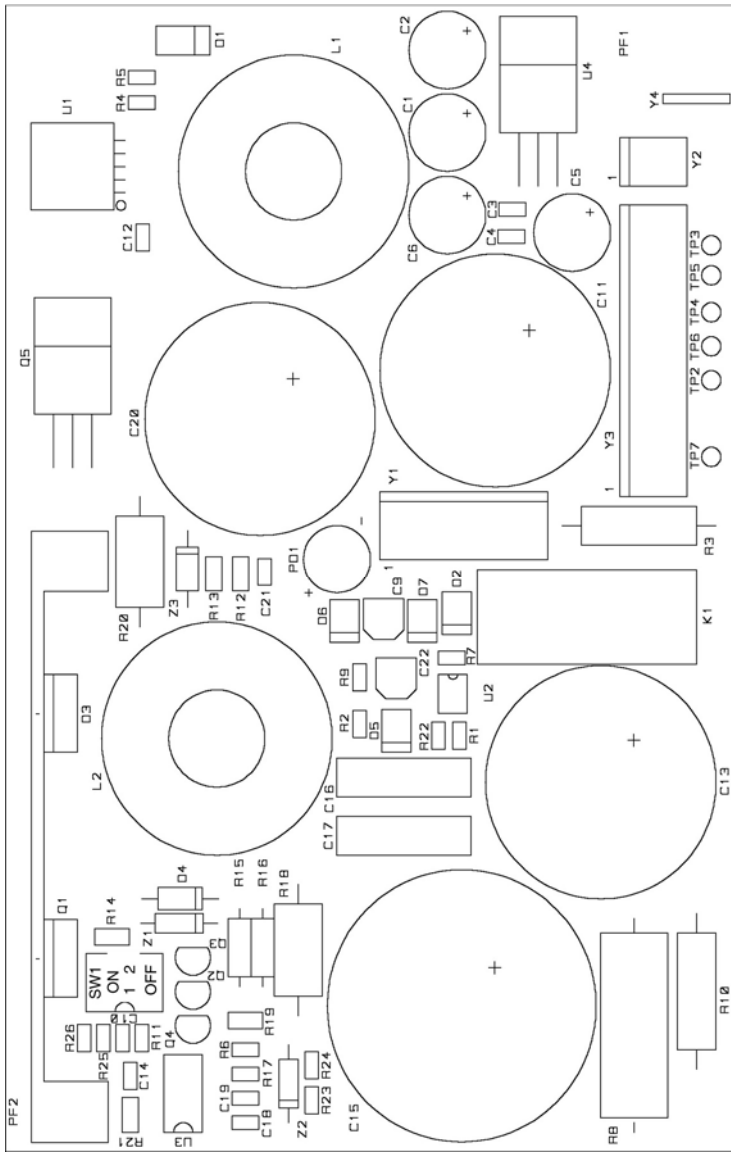

PICTURE 23 POWER SUPPLY - layout

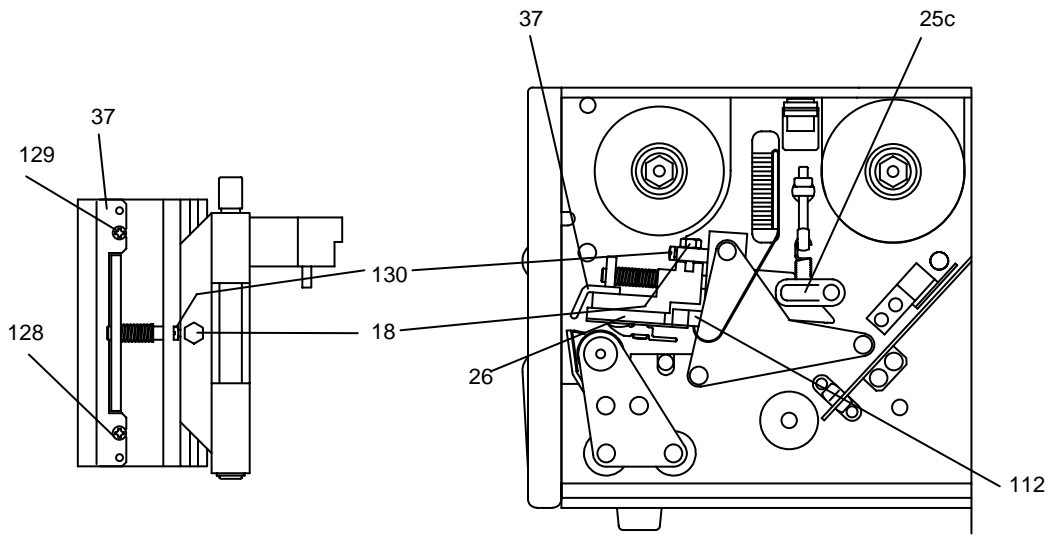

PICTURE 26

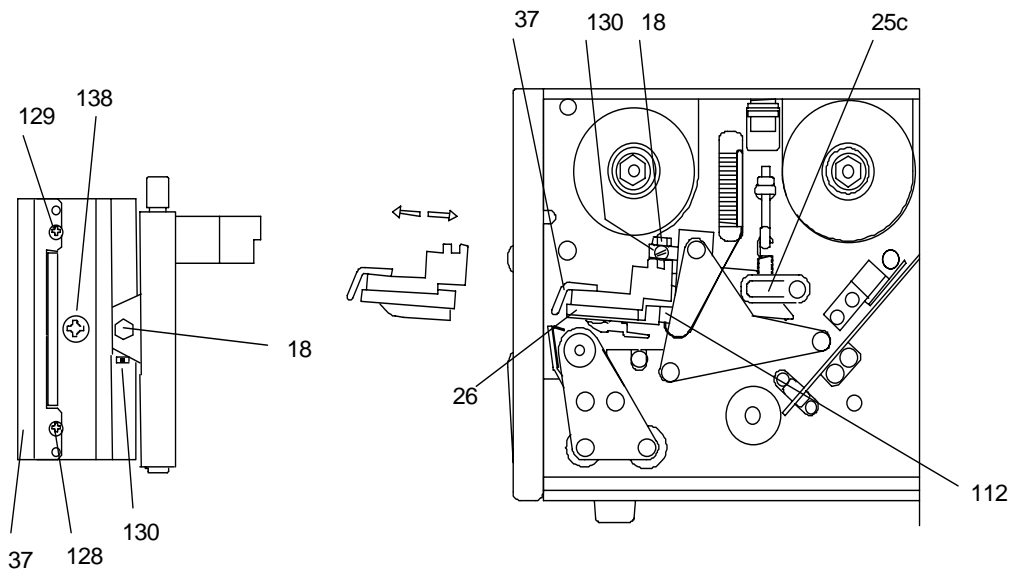

PICTURE 27

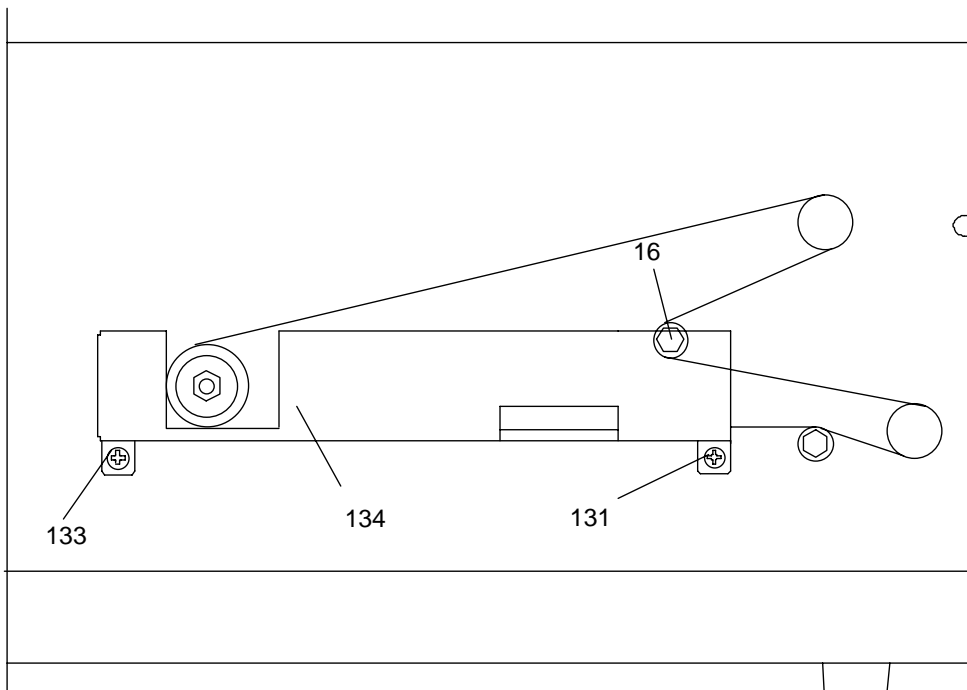

PICTURE 28

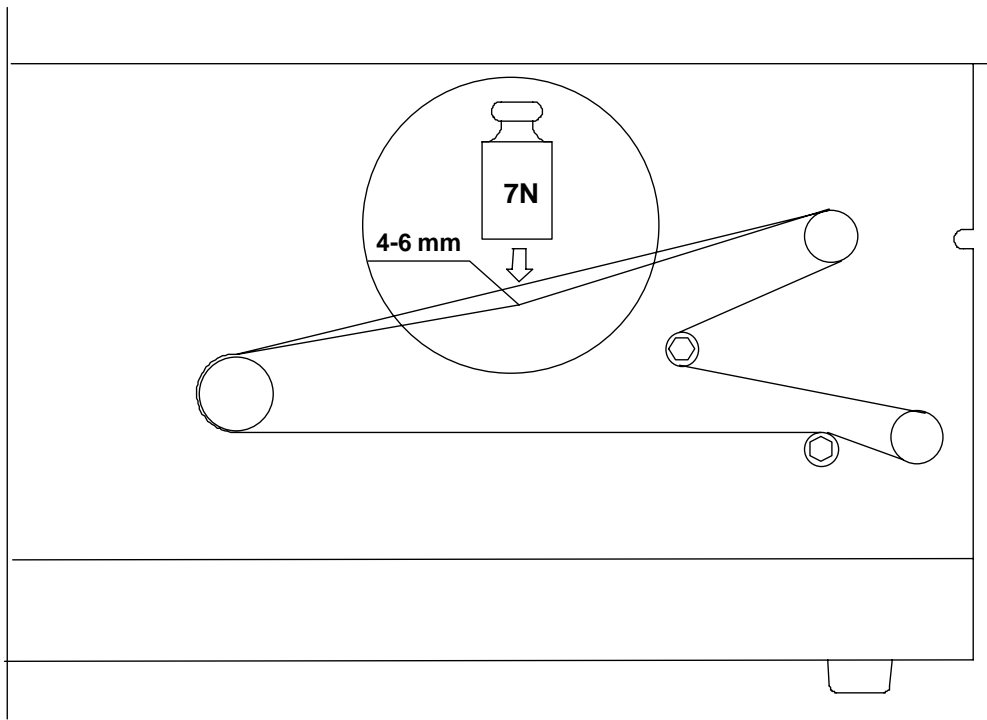

PICTURE 29

### 15. PART LIST AND RELEVANT PICTURES

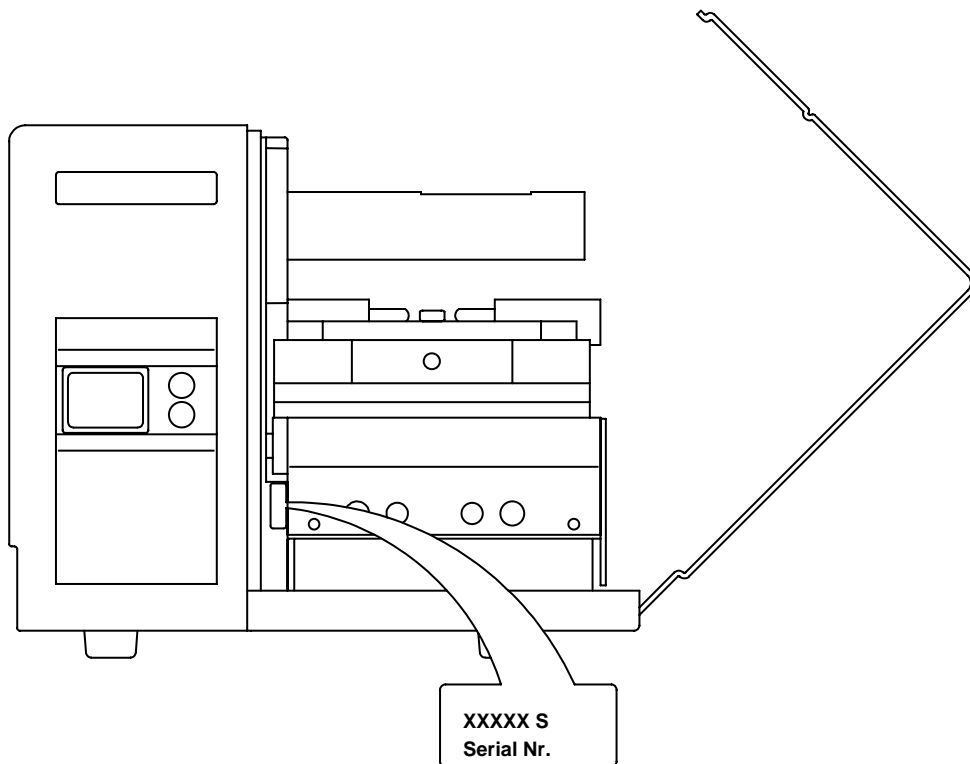

## Spare parts list

(items are referred to following pictures)

ITEM	CODE	DESCRIPTION	smart 630	smart 830
3	800947020	rear panel	*	*
4	801292050	filter cap	*	*
5	056102080	fuse 2A T	*	*
6	056102020	fuse 1.6A T	*	*
8	801665050	RS232 connector	*	*
9	056102030	fuse 8A T	*	*
10	801295040	label photosensor	*	*
12	801665210	flat cable	*	*
13	800945H3000	power board	*	*
16	800925310	belt idler assembly	*	*
18	800722460	nut	*	*
19	061702070	bush	*	*
20	800926290	peeling plate assembly	*	*
21	801842380	feeding roller	*	*
23	800742100	spring	*	*
24	801842660	pinion	*	
24	801872020	pinion		*
25	800925890	print head lever	*	*
26	801862010	thermal print head (6 dots per mm)	*	
26	800822011	thermal print head (8 dots per mm)		*
28	801842130	clip holder	*	*
29	800942690	ribbon rewinding assembly	*	*
30	800942700	ribbon stock assembly	*	*
31	801845083	side cover	*	*
33	810940029	media position holder assembly	*	*
35	80184246201	green front cover	*	*
36	801842083	electronic cabinet	*	*
37	800542410	ribbon plate	*	*
38	801842060	belt	*	*
39	801622160	ribbon rewinding gear	*	*
44	800925340	green front cover (movable)	*	*
48	801625030	ribbon photosensor	*	*
49	800946970	stepping motor assembly	*	
49	800946610	stepping motor assembly		*
50	80166584003	CPU board 25DS04	*	
50	80166584004	CPU board 25DS04		*
51	800926330	heat dissipater assembly	*	
51	800926320	heat dissipater assembly		*
52	801842501	tie rod	*	*
55	800925280	ring clip	*	*

### For PARALLEL CENTRONICS version

3	800947100	rear panel	*	*
8	801665120	Centronics connector	*	*
50	80166584013	CPU board 25DS04	*	
50	80166584014	CPU board 25DS04		*
54	800925761	Centronics interface board	*	*

