



User manual

Smart 2000
Smart 2000 CS
Smart 3000 CS

with Electronic EL7B

Rev.1

 **italora**

1 Revisions table

Version No.	Date	Revision description
0	03/03/2022	Updated to Electronic EL7B
1	04/07/2023	Graphics updates, internal components updated

2

Summary

1	REVISIONS TABLE	2
2	SUMMARY	3
3	TECHNICAL SPECIFICATIONS	4
4	PRINTING MEDIA DESCRIPTION	5
	Paper specifications.....	5
	Thermal ribbon specifications	5
5	PACKAGE CONTENTS	6
6	MAIN FEATURES	7
7	INITIAL INSPECTION	8
8	LABEL FORMAT SETUP PROCEDURE	9
9	EXTERNAL DESCRIPTION	10
10	DESCRIPTION OF THE MAIN COMPARTMENT	11
12	REPLACING THE THERMAL RIBBON ROLL	12
13	REPLACING THE LABEL ROLL	13
	Dispensing mode.....	13
	Strip form mode	14
	Rewinding mode	15
14	CLEANING	16
	Printhead	16
	Feed roller	16
	Photosensor	16
	Metallic and plastic parts	16
	Adhesive traces or parts of labels.....	16
15	MAINTENANCE	17
	Printhead alignment	17
	Printhead replacement.....	18
	Access the electronics compartment	19
	CPU board and power supply replacement	20
	Drive belt replacement	21
	Fuses replacement	22
16	TROUBLESHOOTING	23
17	CPU BOARD CONNECTORS	26
18	REPLACEMENT PARTS	28

3 Technical specifications

	Smart 2000	Smart 2000 CS	Smart 3000 CS
Printing method	direct thermal and thermal transfer		
Printing mode	dispensing, rewinding and strip		
Printing speed	up to 170mm/s	up to 250mm/s	up to 200mm/s
Resolution	8 dot/mm - 200 DPI		12 dot/mm - 300 DPI
Printing area	up to 102x1200mm		up to 108x500mm
Media types	die cut labels, tags and continuous strips		
Labels sizes	width 30 to 110mm spacing 2mm minimum depth 7mm minimum from inner edge		
Labels length	10 to 1200mm		10 to 500mm
Media roll sizes	external diameter up to 150mm - internal diameter 40mm		
Thermal ribbon width	35 to 110mm		
Thermal ribbon sizes	width 220m maximum external diameter 58mm maximum internal diameter 25.4mm		
Display	-		
Keypad	print button		
Sensors	paper end and sync, thermal ribbon end, printhead temperature		
CPU	32bit RISC 40MHz		
Memory	64MB flash - 32MB RAM		
Communication ports	RS232/422/485, USB, Ethernet		
Power requirements	90/260 VAC 50/60 Hz		
Fuses	mains 2xT2A		
Operating temperature and humidity	0/40°C - 10/95% non-condensing		
Storage temperature	-20/60°C		
Sizes and weight	220x235x440mm (HxWxD) - 15Kg		

4 Printing media description

Paper specifications

Paper

woodfree pigmented white with glossy finish	
weight	65 ÷ 90 g/mq (ISO536)
thickness	0.075 ÷ 0.083 mm (ISO534)

Adhesive

peel adhesion (90°C)	430 N/m
operating temperature	-20 ÷ 70 °C

Backing paper

BG 40 brown, supercalendered glassine paper	
weight	65 g/mq (ISO536)
thickness	0.057 mm (ISO534)
transparency	45%

Tags and continuous strip

weight	200 g/mq max
--------	--------------

Printing media

Materials suitable for direct thermal printing or thermal transfer (the materials used affect print quality and speed)

Labels and tickets sizes

width	30 to 110 mm
length	10 to 1200 mm (Smart 2000)
	10 to 1200 mm (Smart 2000 CS)
	10 to 500 mm (Smart 3000 CS)
spacing	2 mm minimum
depth	7mm minimum from inner edge

Thermal ribbon specifications

Film

thickness	4.5 ÷ 6 µm
internal diameter	25.4 mm
external diameter	58 mm max
width	35 ÷ 110 mm
length	220 m = ∅ 58 mm

Recommended carbonated ribbons

TOIKO C 250 (for matt paper)	
TOIKO CR 150 (for glossy paper and polypropylene)	
TOIKO R 300 (for plastic media)	

Store labels and ribbons in a dry place at a temperature below 40°C.
Avoid exposure to sunlight.

5

Package contents

Check if the content of the package is the following:

- **italora** printer model **Smart 2000** or **Smart 2000 CS** or **Smart 3000 CS**
- power cable
- labels roll
- thermal ribbon roll
- RS232 serial cable
- USB cable
- print test

6 Main features

These printers offer high print quality, the ability to hold up to 1500 labels (106x70mm) and to save up to 26 formats in flash memory.

They support printing, through XY positioning, of:

- fixed and variable texts (26+12 preloaded fonts), counters and date/time fields via internal RTC
- barcode
- programmable graphics and rectangles, lines and shaded areas

There is also the possibility to add fonts and update the firmware through PC.

There are some options available such as:

- label taken photosensor
- cutter
- external labels roll holder with 220mm maximum diameter
- Pick & Place interface with optoisolated signals
- WiFi interface
- ETIK graphical label editor for Windows

7 Initial inspection

Open the main compartment, check the presence of the label and thermal ribbon rolls and lower the printhead by moving the lever #25 to work position #25a (see chapter “Description of the main compartment”).

Connect the printer to a computer and to the power and turn on the printer using switch #103 on the rear panel (see chapter "External description").

The red and green LEDs will light up steadily: this means the printer is ready.

Press the print key #1 (see chapter "External description") to print a test label with the main parameters and information of the printer.

By sending data from a computer, a label will be printed.

Press the print key #1 to reprint the last label sent.

The printer stores the size and transparency values of the media type in use.

If the type of label is changed, refer to the chapter “Label format setup procedure”.

8

Label format setup procedure

The printer stores the format and transparency values of the label.

If the type or size of label is changed, it is necessary to perform the following procedure to update the stored parameters:

- Turn off the printer and check that the print media is correctly positioned under the photosensor, as indicated in the chapter “Replacing the label roll”.
- Turn on the printer while holding down the print button #1 (see chapter "External description"). A few blank labels will be output as the printer reads the new transparency values.

At the end of the procedure the printer will return to normal operating conditions, with the red and green LEDs on steady.

For more information about the print media that can be used on these printer models, refer to the chapter “Printing media description”.

9 External description

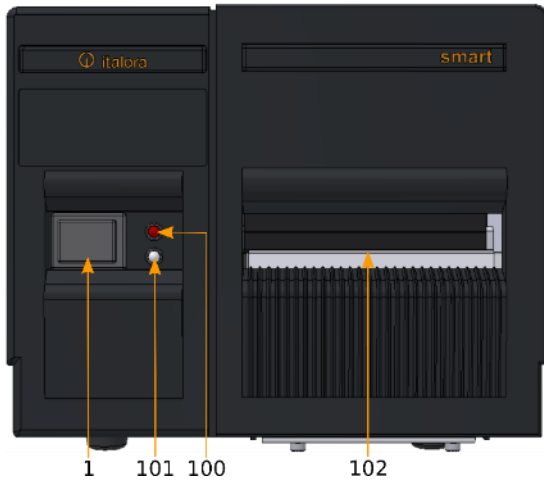

- 1 print button
- 100 power LED
 - red → printer on
- 101 status LED
 - fixed green → normal operation
 - blinking green → paper end
 - fixed yellow → syntax error
 - blinking yellow → printed overheating
 - blinking yellow/green → ribbon end
- 102 label exit

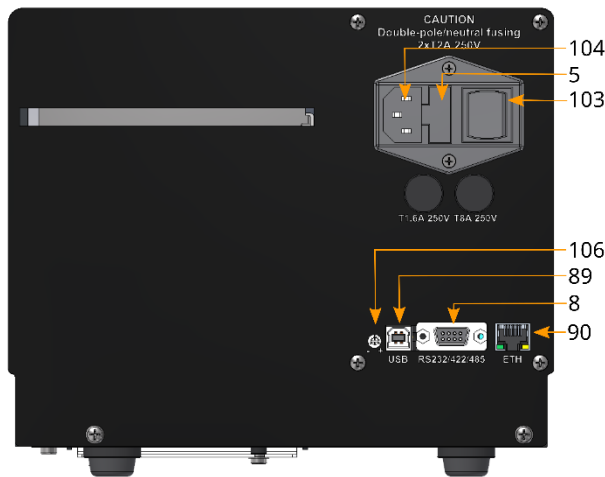

- 5 2x T2A fuse (main)
- 8 serial port
- 89 USB 2.0 type B port
- 90 RJ45 Ethernet port
- 103 main switch
- 104 IEC C14 power plug
- 106 print intensity trimmer
 - ↻ rotation → higher intensity
 - ↻ rotation → lower intensity

10 Description of the main compartment

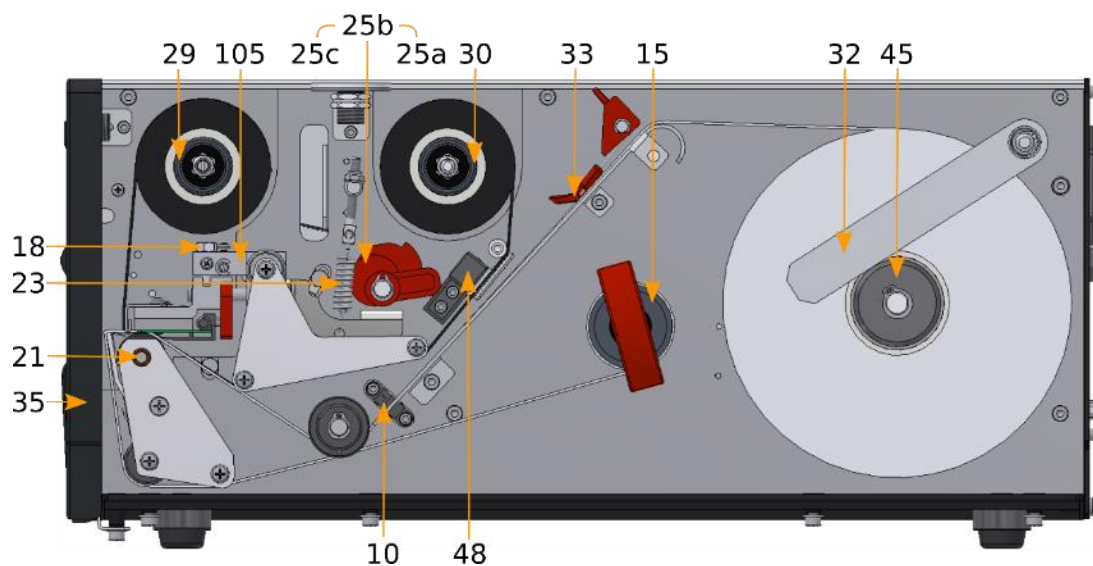

- 10 paper end and sync fork photosensor
- 15 rewinding shaft with adjustable clutch
- 18 printhead position adjustment
- 21 rubber feed roller
- 23 printhead pressure spring
- 25 printhead position lever
 - 25a working position
 - 25b lifted position
 - 25c cleaning position
- 29 thermal ribbon rewinder
- 30 thermal ribbon stock
- 32 label guide arm
- 33 pressure clip
- 35 front cover
- 45 label stock
- 48 ribbon end reflection photosensor
- 105 printhead assembly

12 Replacing the thermal ribbon roll

Open the main compartment and remove the ribbon rewound on the cardboard tube #47 inserted on the ribbon rewinder #29.

Lift the printhead assembly #105 by turning the lever #25 to position #25b, freeing up access to the feed roller #21. Insert a new roll of ribbon #43, taking care to slide the ribbon underneath the reflective photosensor #48 and the transmissions #108, #107 and #37, until reaching the rewinder #29.

Attach the tape to the cardboard tube #47 using an adhesive media.

Lower the printhead assembly by moving lever #25 to working position #25a and close the main compartment.

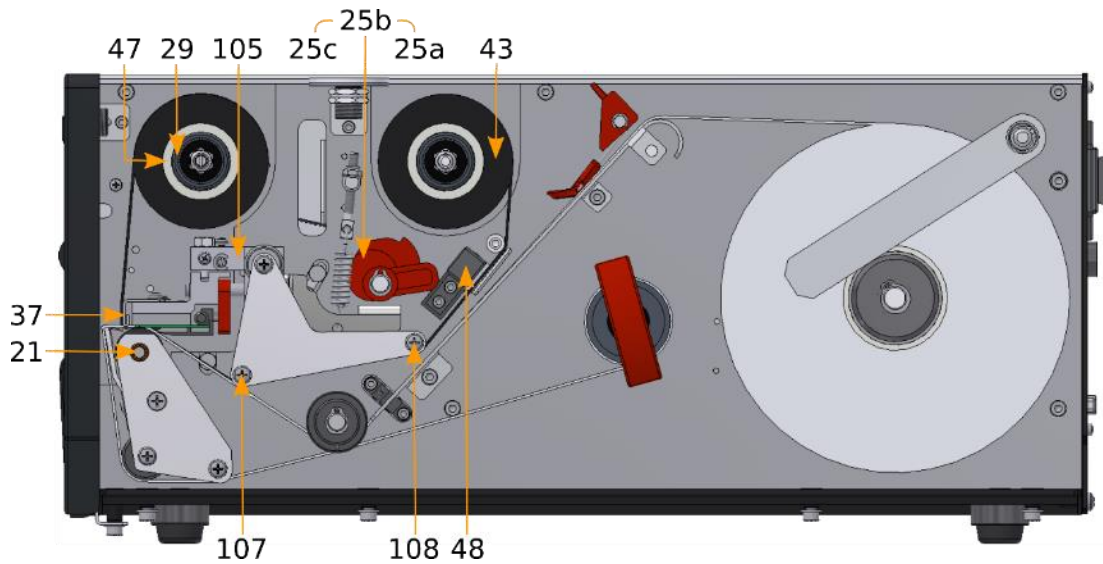

13 Replacing the label roll

If the label format or the type of print media is changed, perform the "Label format setup procedure".

Dispensing mode

Open the main compartment and remove the empty roll.

Lift the paper guide arm #32 and insert the new label roll onto roller #45.

Lower the paper guide arm #32, placing it against the side of the roll.

Lift the printhead assembly #105 by turning the lever #25 to position #25b, freeing up access to the feed roller #21.

Remove clip #28 from the rewinding shaft #15 and remove the backing paper.

Remove the first labels from the new roll leaving about 50cm of backing paper.

While holding up the pressure clip #33, slide the paper up to rewind roller #15, rolling it over and locking it with clip #28.

Rotate the rewinder to tighten the paper.

Lower the printhead assembly by moving lever #25 to working position #25a.

Check that the paper is positioned correctly under the fork photosensor #10 and that the pressure clip #33 is placed between the center and the outer edge of the label.

Close the main compartment.

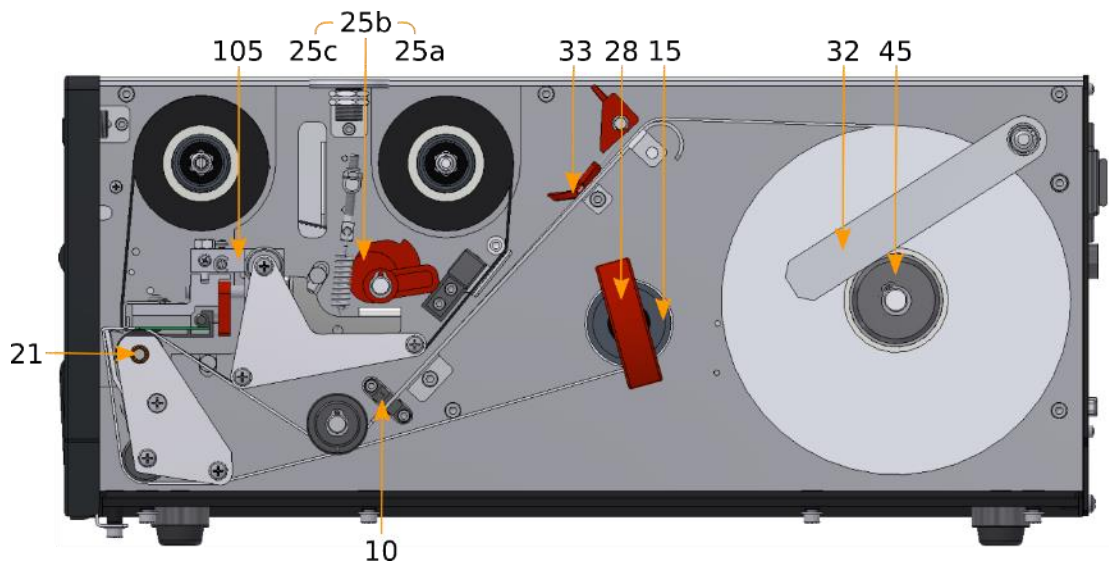

Strip form mode

Open the main compartment and remove the empty roll.

Lift the paper guide arm #32 and insert the new label roll onto roller #45.

Lower the paper guide arm #32, placing it against the side of the roll.

Lift the printhead assembly #105 by turning the lever #25 to position #25b, freeing up access to the feed roller #21.

While holding up the pressure clip #33, slide the paper between the feed roller #21 and the printhead #105.

Lower the printhead assembly by moving lever #25 to working position #25a.

Check that the paper is positioned correctly under the fork photosensor #10 and that the pressure clip #33 is placed between the center and the outer edge of the label.

Close the main compartment.

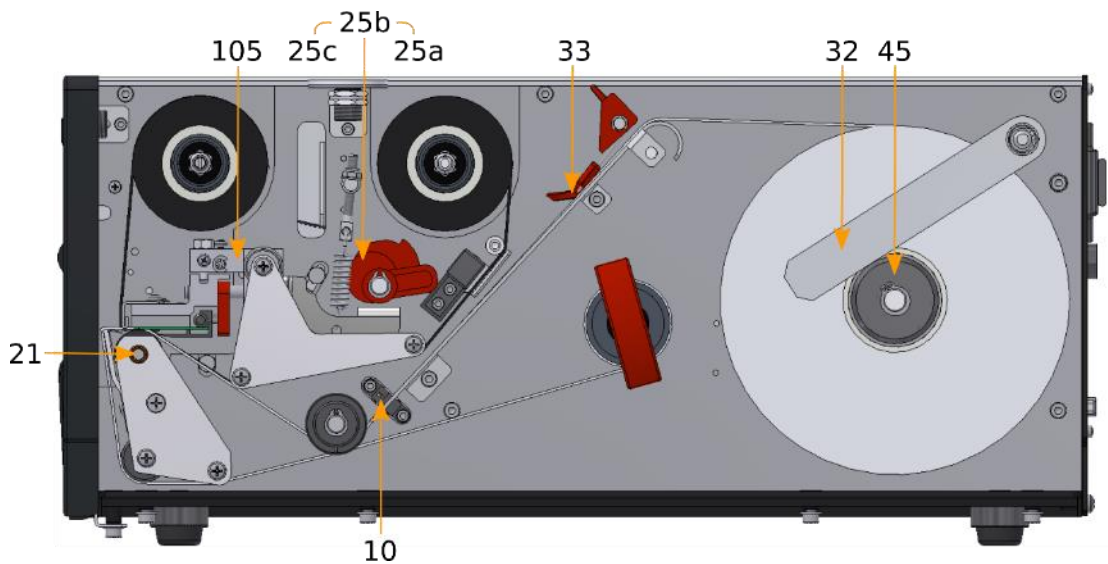

Rewinding mode

To rewind printed labels inside the printer, it is necessary to remove the plate #20 by unscrewing screws #139 and #140.

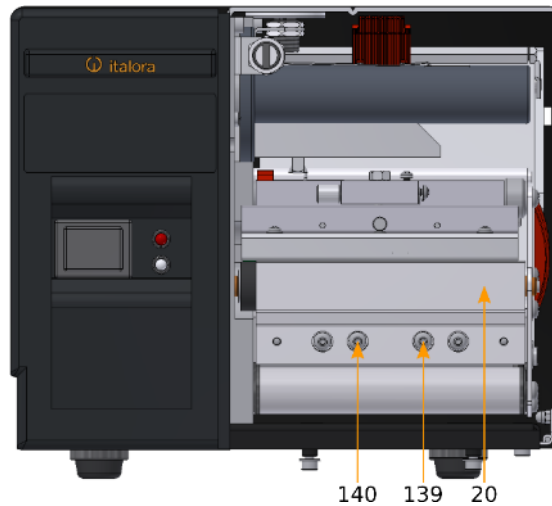

Open the main compartment and remove the empty roll.

Lift the paper guide arm #32 and insert the new label roll onto roller #45.

Lower the paper guide arm #32, placing it against the side of the roll.

Lift the printhead assembly #105 by turning the lever #25 to position #25b, freeing up access to the feed roller #21.

Remove clip #28 from the rewinding shaft #15 and remove the backing paper.

Remove the first labels from the new roll leaving about 50cm of backing paper.

While holding up the pressure clip #33, slide the paper up to rewind roller #15, rolling it over and locking it with clip #28.

Rotate the rewinder to tighten the paper.

Lower the printhead assembly by moving lever #25 to working position #25a.

Check that the paper is positioned correctly under the fork photosensor #10 and that the pressure clip #33 is placed between the center and the outer edge of the label.

Close the main compartment.

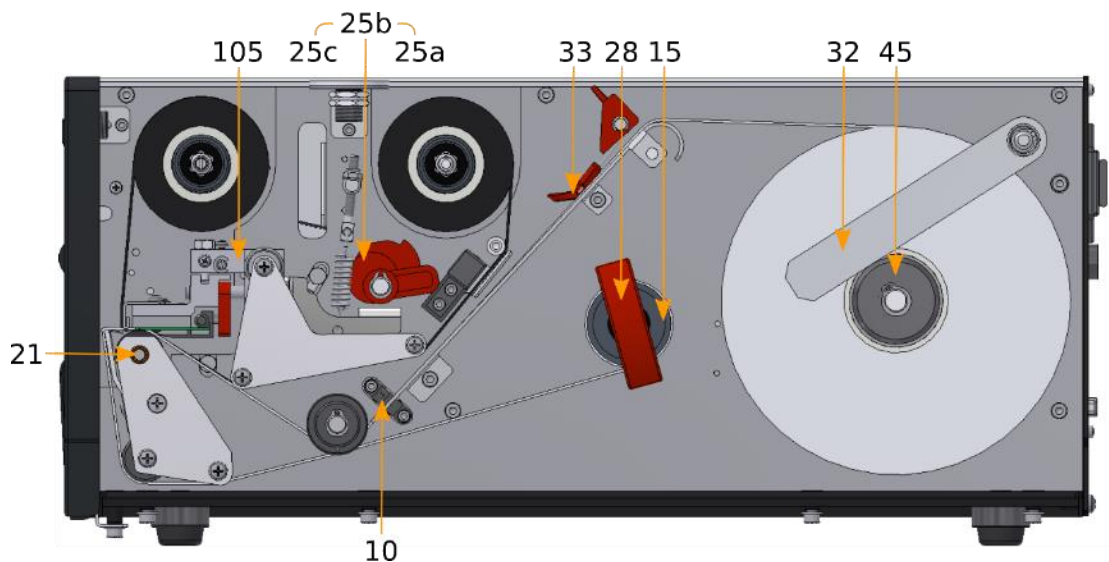

14 Cleaning

Printhead

Turn off the printer and wait for the printhead to cool down.

Lift the printhead assembly #105 by turning the lever #25 to position #25c and remove the thermal ribbon roll.

Wipe the underside of the printhead with a soft cotton cloth moistened with denatured alcohol.

Never use metal or sharp tools, as they could cause irreparable damage to the printhead.

Wait for the cleaned parts to dry before using the printer.

Feed roller

Turn off the printer.

Lift the printhead assembly #105 by turning the lever #25 to position #25c and remove the labels roll.

Clean the feed roller using alcohol-based cleaners.

Photosensor

Turn off the printer.

Lift the printhead assembly #105 by turning the lever #25 to position #25b and remove either the labels or thermal ribbon roll depending on the photosensor to be cleaned.

Use a soft brush to clean.

Metallic and plastic parts

Use a soft cloth moistened with a detergent.

Do not use solvents or thinners.

Adhesive traces or parts of labels

Use denatured alcohol making sure that drops of liquid do not come into contact with electrical parts.

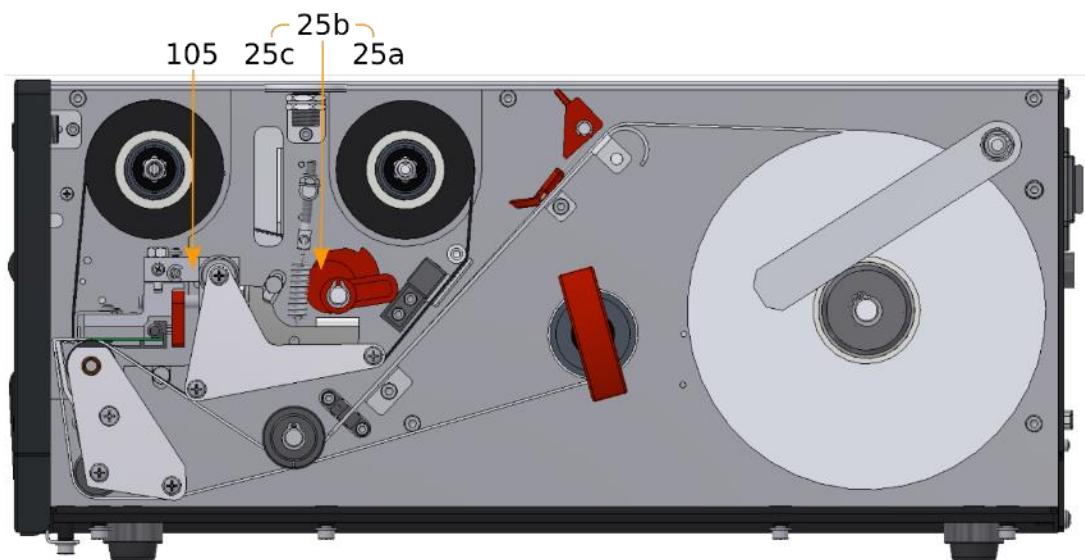

15 Maintenance

If the printer is not used for prolonged periods of time, it is recommended to turn it off and lift the printhead assembly #105 to avoid damaging the rubber feed roller #21.

Printhead alignment

To have the best print quality, the dots of the printhead must be aligned with the tangency point of the feed roller.

If this alignment is incorrect, the printout may be faded and the ribbon may crease. The presence of these creases can cause the thermal ribbon to rewind incorrectly and produce white print areas.

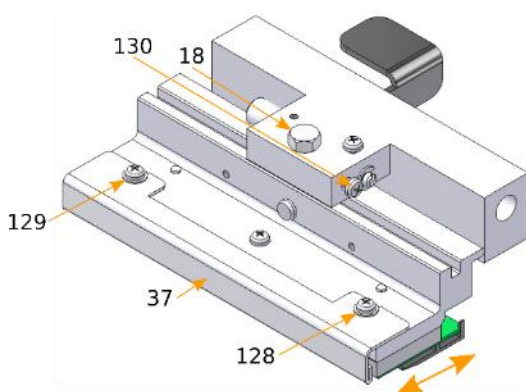

The fine-tuning of this alignment can be done by rotating the eccentric nut #18 placed in the center of the printhead assembly, thus adjusting the position of the printhead with respect to the tangent point of the feed roller.

A rotation of 360° and multiples will bring the printhead back to the initial position; adjust the eccentric nut by turning it a few degrees at a time.

Before proceeding with the adjustment, it is necessary to loosen the locking screw #130.

In case the thermal ribbon is not rewound with sufficient tension, loosen screws #128 and #129 and adjust the alignment of plate #37 until correct rewinding is obtained. Finally lock the screws.

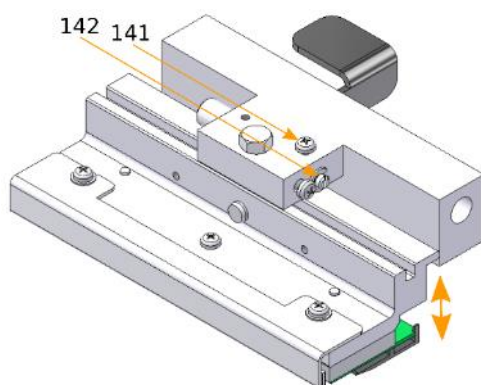

If the label is lighter on one side, it will be necessary to turn the slotted screw #142 to adjust the angle of the printhead. By turning this screw clockwise or counterclockwise it is possible to increase or decrease the pressure of the printhead on one side of the label.

By acting on this adjustment it will also be possible to solve any alignment problems of the thermal ribbon with the feed roller and eliminate any crease.

Before proceeding with the adjustment, it is necessary to loosen the locking screw #141.

This procedure is especially useful when printing on narrow labels.

Printhead replacement

Turn off the printer, lift the printhead assembly #105 by turning the lever #25 to position #25c and remove the thermal ribbon roll.

Disconnect cable #112 (or cables, in case of **Smart 2000/3000 CS**) on the back of the head and unscrew screw #138.

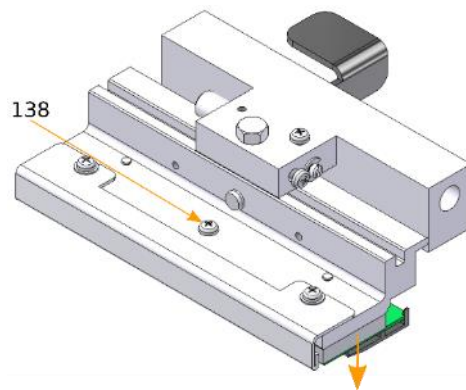

The printhead has two holes that match two pins on the support: remove it by pulling it downwards.

Replace the printhead by proceeding backwards with the operations just performed.

Pay close attention to the connection of the printhead: incorrect insertion of cable #112 (or cables, in case of **Smart 2000/3000 CS**) could cause irreversible damage to the printhead itself.

In case of print quality problems, refer to the "Printhead alignment" chapter.

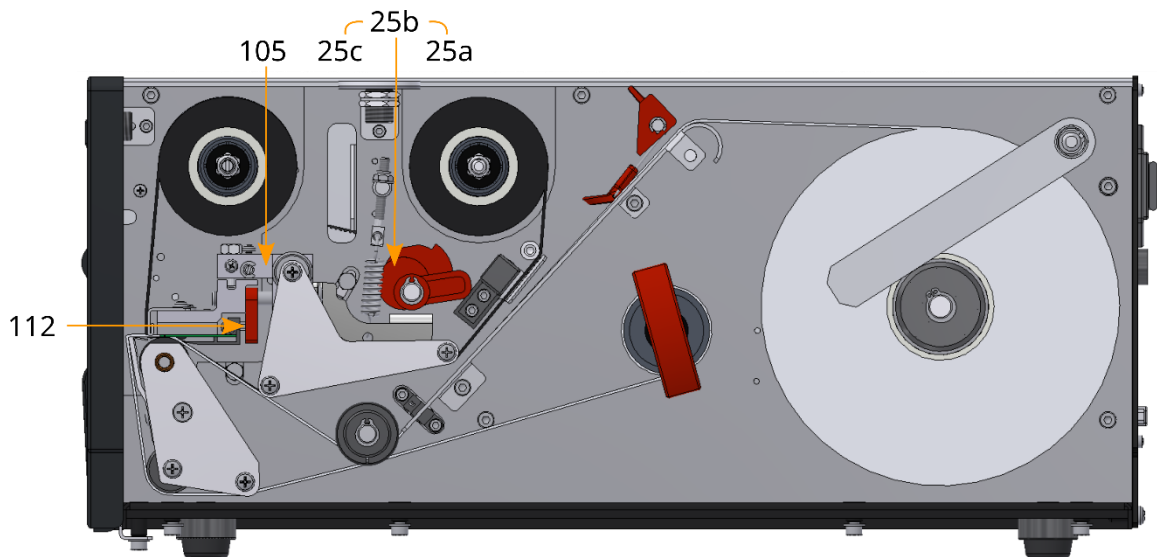

Access the electronics compartment

Before accessing the electronics compartment, **disconnect** the printer power cable.

Open the main compartment and unscrew screws #114, #115, #116, #119, #120 and #121. Unscrew the screws #117 and #118 from the rear panel.

Separate the electronics compartment from the base structure and disconnect the following connectors from the CPU board (see chapter "CPU board connectors"):

- Y2 thermal ribbon photosensor
- Y3 LEDs and print button
- Y4 stepper motor
- Y5 labels photosensor
- Y9 printhead (**Smart 2000**)
- YGM printhead (**Smart 2000/3000 CS**)
- Y15 printhead power (**Smart 2000/3000 CS**)

Disconnect the ground cable by unscrewing the nut on the base structure.

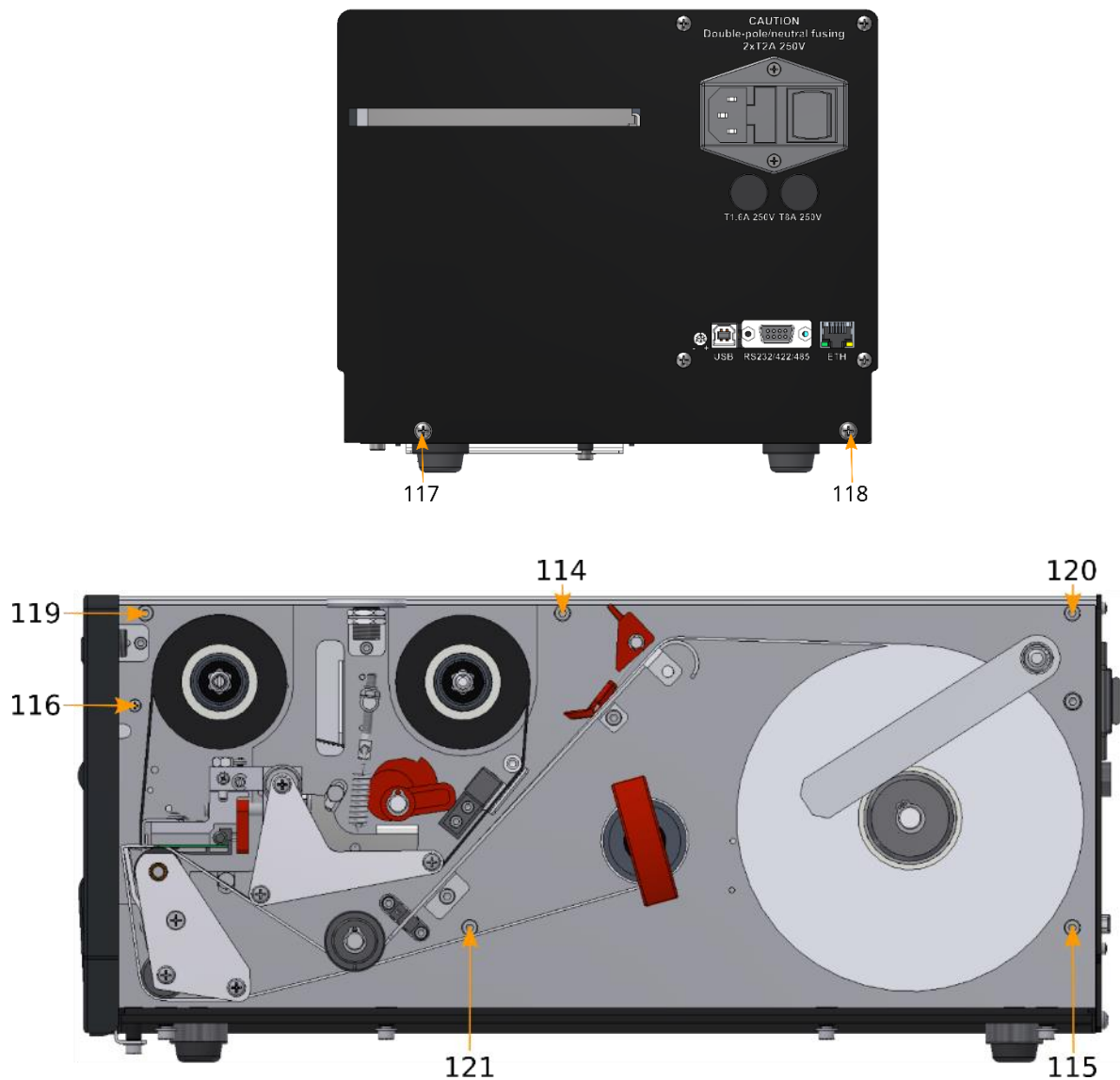

CPU board and power supply replacement

Follow the procedure indicated in the “Access the electronics compartment” chapter to separate the electronics compartment from the base structure of the printer.

Disconnect the following connectors from the CPU board (see chapter “CPU board connectors”):

- Y1 RJ45 Ethernet interface
- Y13 DB9 serial interface
- Y29 USB 2.0 type B interface
- Y30 power supply

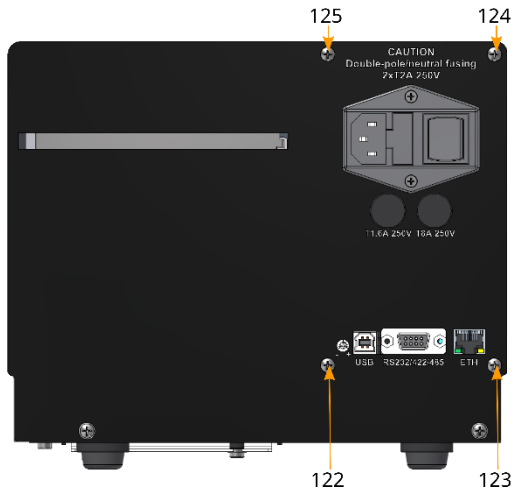

Remove screws #122, #123, #124 and #125 from the rear panel.

Unscrew the side grub screw #113 and then remove the CPU board #50.

Disconnect the connector of the mains switch. Unscrew grub screws #126 and #127 then remove power supply board #13.

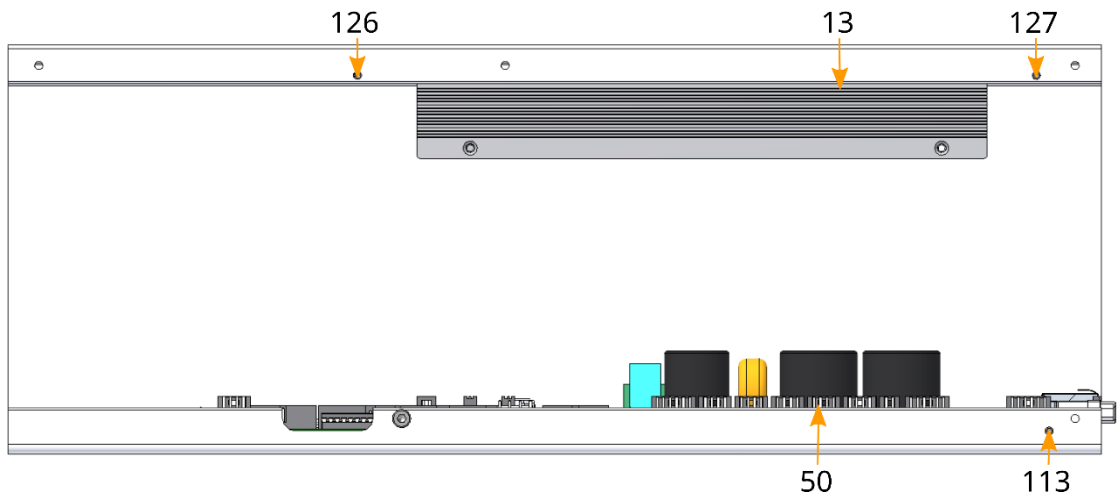

Drive belt replacement

Follow the procedure indicated in the “Access the electronics compartment” chapter to separate the electronics compartment from the base structure of the printer.

Remove the protection plate #134 by unscrewing the screws #131 and #133.

Loosen the belt tensioner #16 and proceed with the replacement of the belt, subsequently adjusting its tension using the belt tensioner itself.

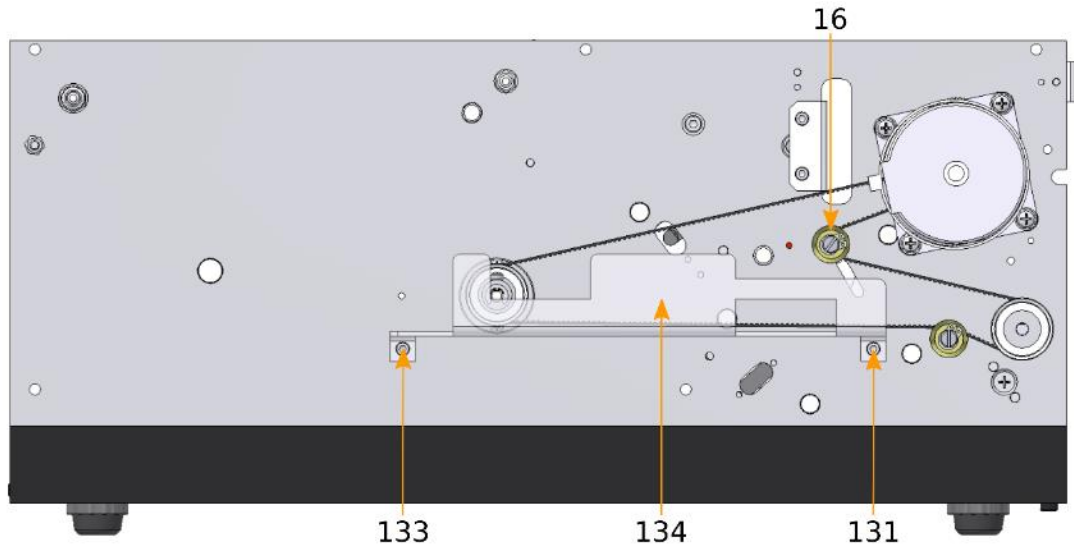

Fuses replacement

Turn off the printer and disconnect it from the mains before replacing any fuse.

T2A mains fuses

Remove, using a slotted screwdriver, the special plastic support #5 containing the fuses, located on the rear panel.

Replace the damaged fuse and reinstall the plastic holder in the rear panel of the printer.

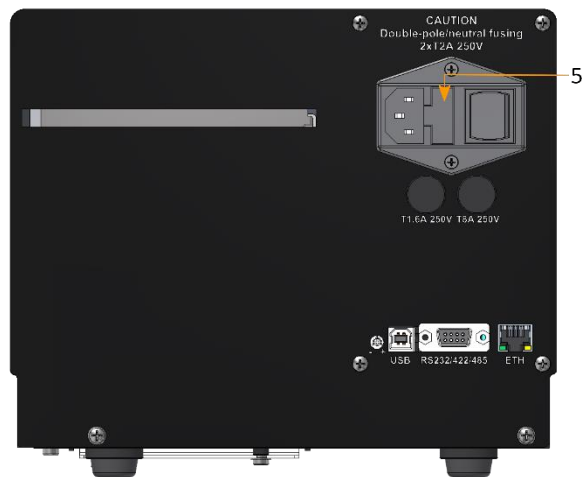

16 Troubleshooting

Labels not advancing

The following conditions may occur:

Red LED off

Check that the power supply #103 of printer is present, that the mains switch #104 is on and that fuses #5 are intact.

Refer to the chapters “External description” and “Fuse replacement”.

Red LED on and status LED blinking green

Check that the roll of labels is not finished and that the paper is correctly positioned under the photosensor #10.

Refer to the chapter “Replacing the label roll”.

Red LED on and status LED blinking yellow/green

Check that the thermal ribbon is not finished and that it is correctly positioned under the reflection photosensor #48.

Refer to the chapter “Replacing the thermal ribbon”.

Red LED on and status LED blinking yellow

Printhead temperature control is active.

The printer waits until the temperature is within the set values.

Red LED on and status LED steady yellow

The printer is in a syntax error condition due to receiving incorrect commands.

Press the print button #1 or turn the printer off and on again using the mains switch #104.

Refer to the chapter “External description”.

Incorrect labels alignment

Make sure that:

- the printhead assembly #105 is in working position, with the lever #25 in position #25a
- the paper is correctly positioned under the fork photo sensor #10
- the backing paper is correctly rewound
- the pressure clip #33 is positioned between the center and the outer edge of the label
- the paper guide arm #32 is positioned against the outside of the label roll

Also follow the chapter “Label format setup procedure”.

Labels slide to the right

Check that:

- the pressure clip #33 is positioned between the center and the outer edge of the label
- the paper guide arm #32 is positioned against the outside of the label

Print defects

Proceed with cleaning the printhead, as described in the “Cleaning - Printhead” chapter.

Check that the thermal ribbon rewinds properly and without wrinkles.

In case of wrinkles, turn the nut #110 clockwise (1/4 of a turn max) while keeping the roller #29 locked, in order to increase the rewind tension.

Labels are not properly peeled off

(valid in dispensing mode)

Make sure that the characteristics of the adhesive comply with the specifications indicated in the chapter "Print media description - Paper specifications”.

Turn the nut #41 clockwise (1 turn max) keeping the roller #15 locked, in order to increase the rewinding tension.

Excessive rewinding tension could cause incorrect label feed.

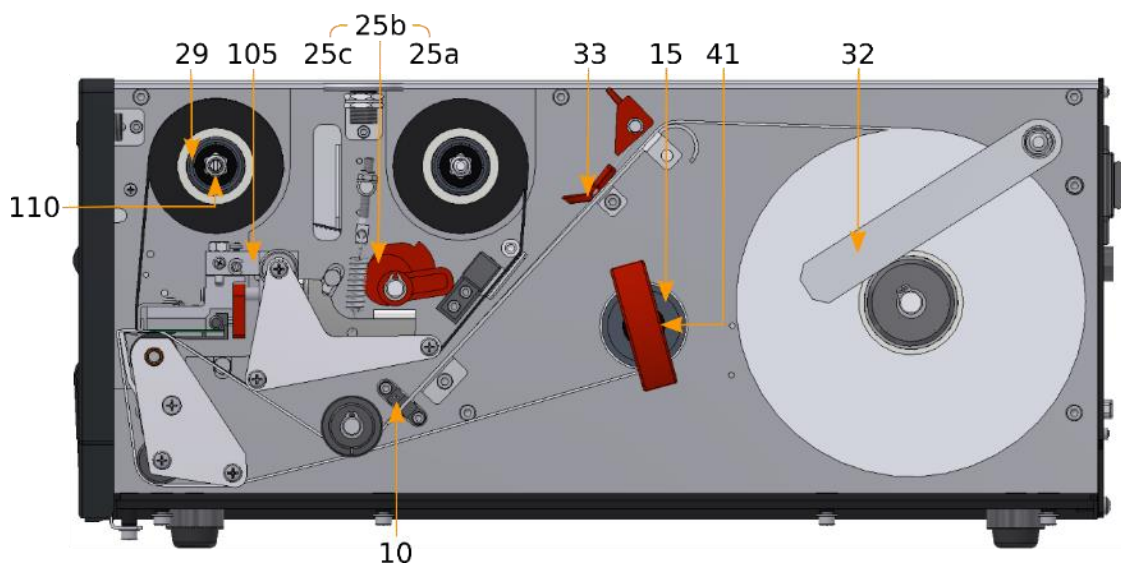

Blank labels

Check that:

- connector #112 of the printhead is correctly connected, with the polarity key upwards, referring to the chapter "Printhead replacement"
- the thermal ribbon is correctly positioned, with the inked surface facing the labels

Insufficient print intensity

Turn trimmer #106, accessible from the rear panel of the printer, clockwise to increase or counterclockwise to decrease the print intensity.

Alternatively, use the software command ?77& described in the "Programming Manual".

Excessive printing intensity could shorten the life of the printhead and cause the thermal ribbon to melt.

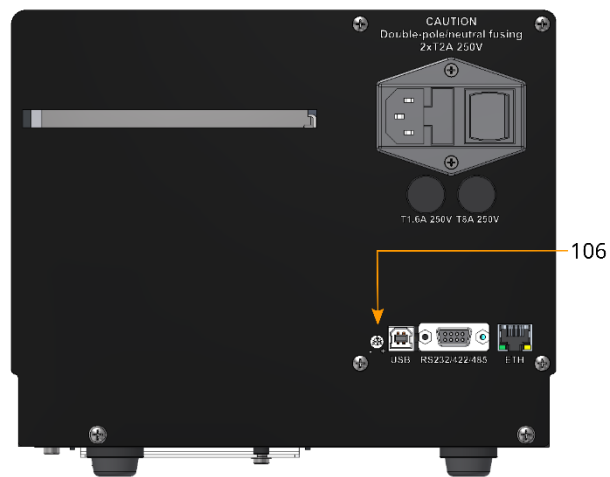

17 CPU board connectors

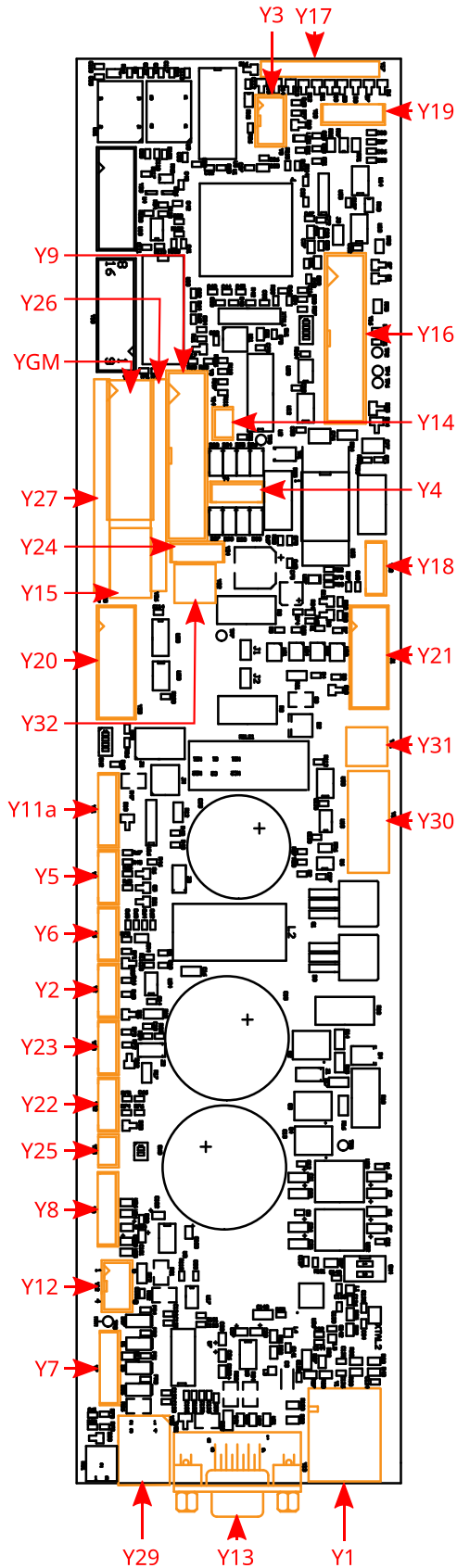

Smart 2000 - Electronic EL7B

- Y1 RJ45 Ethernet
- Y2 Ribbon photosensor
- Y3 Print button and LED
- Y4 Motor
- Y5 Labels photosensor
- Y6 Label taken photosensor
- Y7
- Y8
- Y9 Printhead
- Y10
- Y11a Optoisolated signals
- Y12
- Y13 DB9 serial port
- Y14
- Y15
- YGM
- Y16
- Y17
- Y18
- Y19
- Y20
- Y21
- Y22
- Y23
- Y24
- Y25
- T26
- Y27
- Y28
- Y29 USB 2.0 type B
- Y30 Power supply
- Y31
- Y32

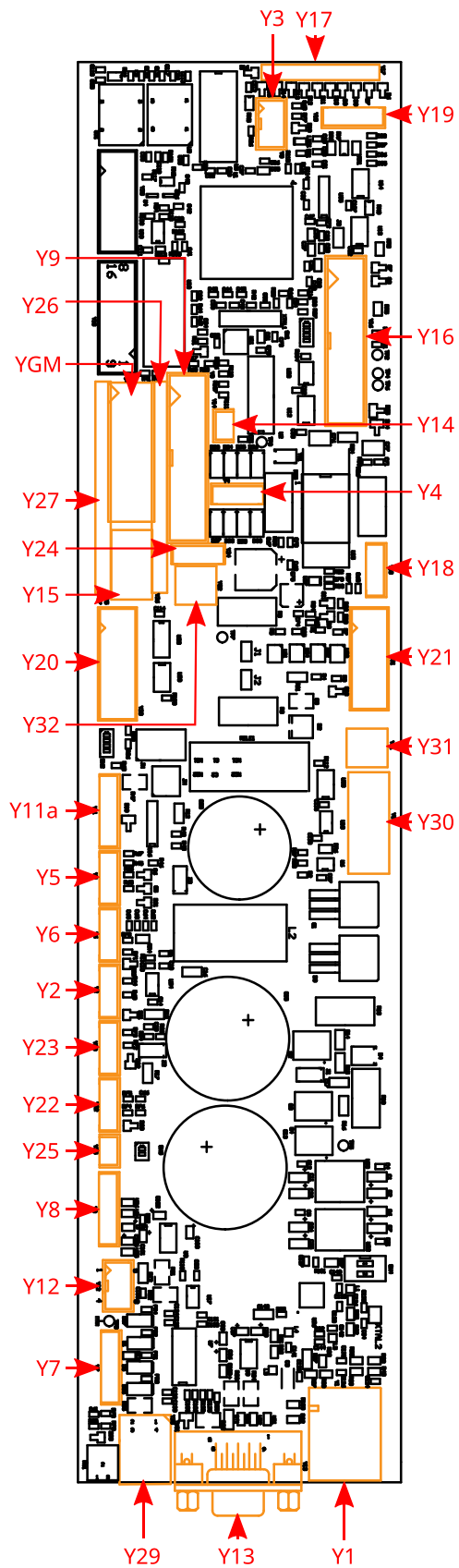

Smart 2000 CS - Electronic EL7B
Smart 3000 CS - Electronic EL7B

- Y1 RJ45 Ethernet
- Y2 Ribbon photosensor
- Y3 Print button and LED
- Y4 Motor
- Y5 Labels photosensor
- Y6 Label taken photosensor
- Y7
- Y8
- Y9
- Y10
- Y11a Optoisolated signals
- Y12
- Y13 DB9 serial port
- Y14
- Y15 Printhead power
- YGM Printhead
- Y16
- Y17
- Y18
- Y19
- Y20
- Y21
- Y22
- Y23
- Y24
- Y25
- T26
- Y27
- Y28
- Y29 USB 2.0 type B
- Y30 Power supply

18 Replacement parts

#	Code	Description	Smart 2000	Smart 2000 CS	Smart 3000 CS
3	80094C650000000	backplate ass. EL7B 106mm	✓	✓	✓
5	PMQC05610208000	T2A fuse	✓	✓	✓
10	PLEQ80129504000	labels photosensor	✓	✓	✓
11	PMA605900669000	printhead power cable		✓	✓
12	PLIB05150766000	printhead 20 pins flat cable		✓	✓
12	PLJU80166521000	printhead 26 pins flat cable	✓		
13	PM9J80094C66000	power supply	✓	✓	✓
16	PLFT80092531000	belt idler assembly	✓	✓	✓
18	PLND80072246000	printhead eccentric nut	✓	✓	✓
19	PLDP06170207000	bushing	✓	✓	✓
20	PLNI80092629000	peeling plate assembly	✓	✓	✓
21	PLFI80184238000	feed roller	✓	✓	✓
23	PLCP80074210000	spring	✓	✓	✓
24	PLKU80187202000	pinion	✓	✓	
24	PLQM80184266000	pinion			✓
25	PLFZ80092589000	printhead lever	✓	✓	✓
26	PT0280081202000	printhead (8 dots)	✓		
26	PT0180081201000	printhead (8 dots CS)		✓	
26	PT0780081207000	printhead (12 dots CS)			✓
28	PMU380076235000	4" clip	✓	✓	✓
29	PLQQ80094269000	ribbon rewinder assembly	✓	✓	✓
30	PLSJ80094270000	ribbon stock assembly	✓	✓	✓
31	PLFX80184508300	side cover	✓	✓	✓
33	PLRK81094002900	pressure clip	✓	✓	✓
34	800762380000000	fixed front cover	✓	✓	✓
36	PLFU80184208300	electronics cabinet	✓	✓	✓
37	PLMR80054241000	ribbon plate	✓	✓	✓
38	PLTW80078232000	belt	✓	✓	✓

39	PLGH80162216000	ribbon rewinding gear	✓	✓	✓
44	800762390000000	movable front cover	✓	✓	✓
48	PLKT80162503000	ribbon photosensor	✓	✓	✓
49	PLE180094661000	stepper motor assembly	✓	✓	
49	PLFY80094697000	stepper motor assembly			✓
50	printer serial number	CPU board	✓	✓	✓
51	PLMX80092632000	heatsink assembly	✓	✓	✓
55	PLNR80092528000	ring clip	✓	✓	✓

