

DISPENSER 3" EL7

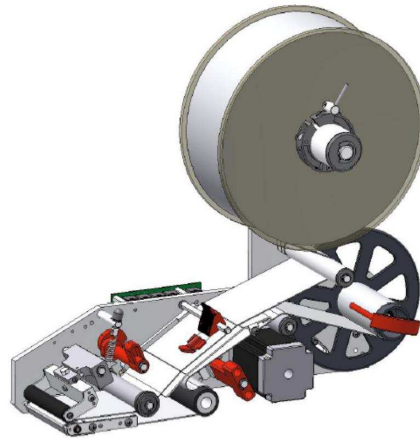

USER MANUAL

 Italora

**Italora S.r.L. Largo Guastalla 7 - 20082 Binasco - (Milano) - Italy
phone +39.02.90092074 - fax +39.02.9055461
www.italora.it
sales@italora.it**

Rel. 02.15

CONTENTS

1. TECHNICAL SPECIFICATIONS	2
2. UNPACKING	2
3. GENERAL VIEW	3
4. ROLLS COMPARTMENT DESCRIPTION	6
5. INCOMING INSPECTION	6
5.1. LABEL FORMAT SET UP PROCEDURE	7
6. LABEL ROLL REPLACEMENT	7
7. PARAMETERS SETTING, DISPLAY AND KEYBOARD	8
7.1. KEYBOARD	8
7.2. MEANING OF DISPLAY COLOURS	16
8. INTERFACING	16
8.1. SERIAL INTERFACE	16
8.2. I/O SIGNALS	17
9. MAINTENANCE	27
9.1. CLEANING	27
10. TROUBLE SHOOTING	28
10.1. NO LABELS FEEDING	28
10.2. INCORRECT LABEL ALIGNMENT	28
10.3. PAPER SLIDES OUTSIDE	28
11. HARDWARE NOTES	28
11.1. HOW TO CHECK ELECTRONIC BOARDS	28
11.2. DRIVE BELT REPLACEMENT	30
12. SCHEMES	31
13. PART LIST AND RELEVANT PICTURES	32

Features and specifications are subject to change without notice

DISPENSER 3" EL7

1. TECHNICAL SPECIFICATIONS

Maximum width (label + backing paper): 90 mm
Speed: up to 350 mm/s

FEEDING

Stepping motor, size 3", 200 steps/rev.

MEMORY

32 – bit RISC microprocessor

8 MB flash

16 Mb RAM

DISPLAY: LCD alphanumeric 16 characters x 2 rows, 8 colours

KEYBOARD: 10 Keys membrane panel

DETECTOR

End of paper and feeding synchronism

MEDIA

Die cut labels

LABEL SIZES

LABEL SIZES

Width: 25 mm min., 90 mm max.

Length: 6 mm min., 1000 mm max.

Key: width min.: 2 mm
depth min.: 20 mm starting
from the inner edge

ROLL SIZES

Width: 25 mm min., 90 mm max.

Outer diameter: 220 mm max.

Core diameter: 45 mm min.

DIMENSIONS

See following pictures

Weights: 6 Kg (Dispenser)

7 Kg (electronic cabinet)

POWER REQUIREMENTS

Voltage: 115/230/240 Vac; 50-60 Hz

ENVIRONMENT

Operating temperature: 0°/ 40° C

Storage temperature: -20°/60° C

Humidity: 10% - 95% non-condensing

2. UNPACKING

Open the box and check the content :

- **italora Dispenser 3" EL7**

- Electronic Control Unit cabinet

- Connection cables

 USB, serial RS232, DB25

- 1 DIN connector 6 poles

- Unwind holder and flanges

- Power cable

- CD Rom with manuals and Etik Light

- Optional photocell detector

- Optional applicator

3. GENERAL VIEW

(See picture 1)

- | | | | |
|----|-----------------------------|------|----------------------|
| 1 | manual printing push button | 42 | connection board |
| 5 | 2 fuses 2AT (main) | 44 | photo cell connector |
| 6: | fuse 1.6AT (logic) | 100 | Display |
| 8A | USB connector | 103: | main switch |
| 8B | RS232 connector | 104: | power cord plug |
| 9 | fuse 8AT | | |

Electronic Control Unit - overall dimensions and fitting holes

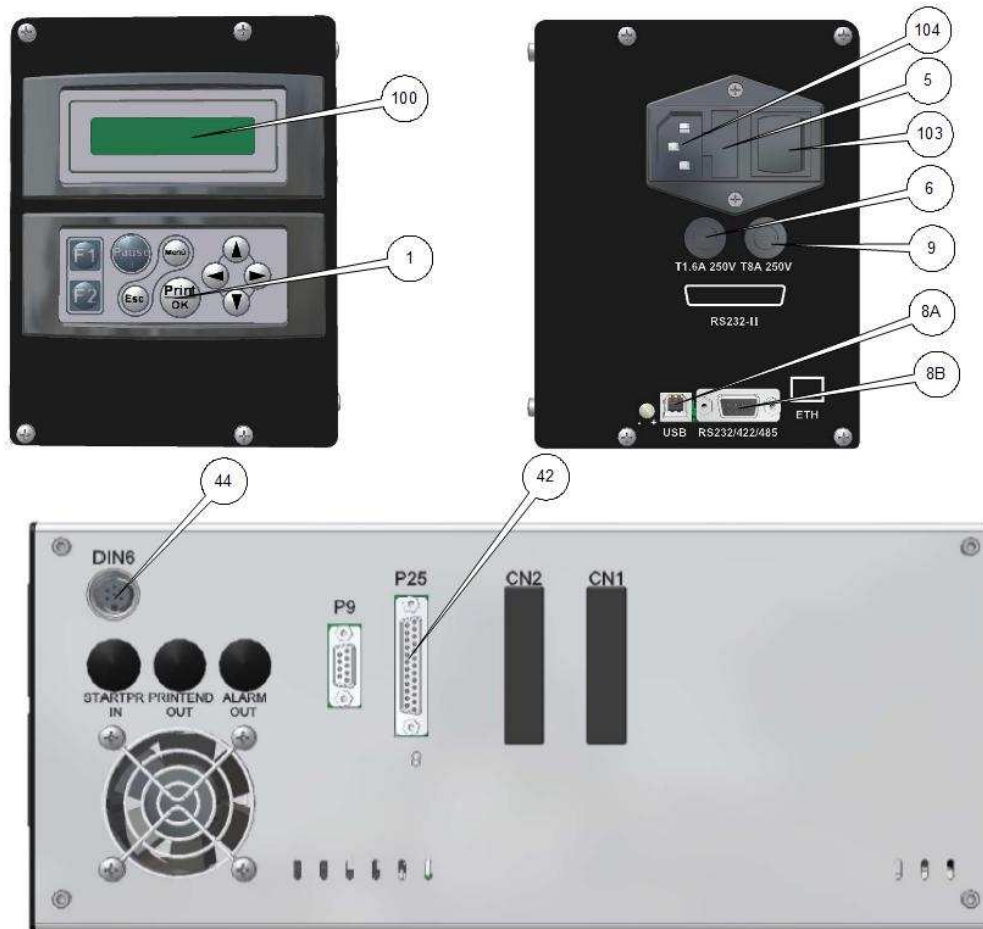

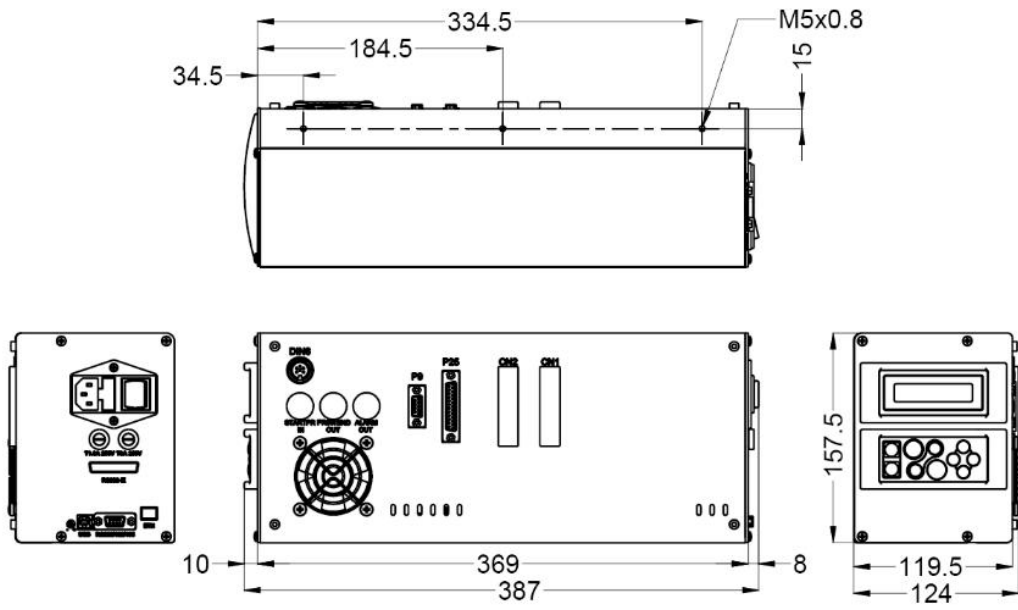

PICTURE 1

Dispenser 3" – overall dimensions and fitting holes

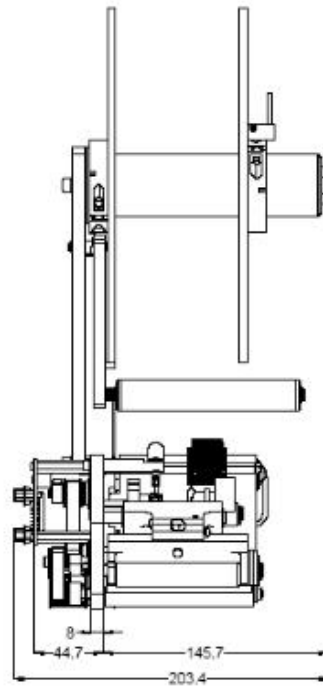
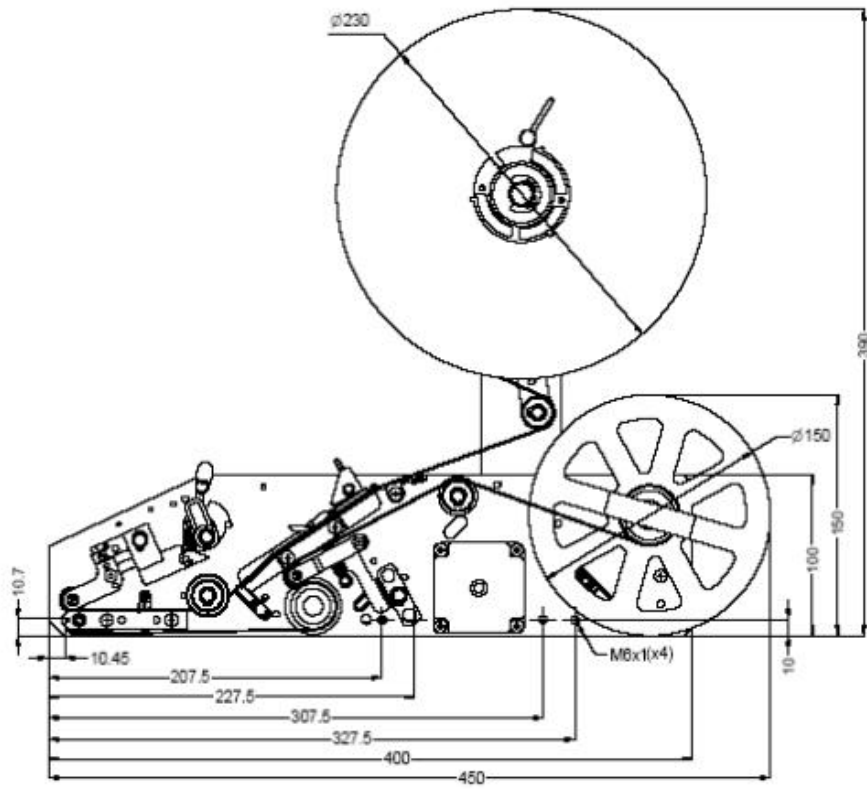

PICTURE 2

4. ROLLS COMPARTMENT DESCRIPTION

(SEE FOLLOWING PICTURES)

- | | | | |
|----|---|-----|------------------------------|
| 10 | - photosensor for end of roll and label synchronisation | 25b | - open position |
| 17 | - lock / unlock toggle lever | 25c | - cleaning position |
| | 17a - working position | 28 | - clip holder |
| | 17b - open position | 32 | - main pressure roller |
| 18 | - pressure roller position fine adjustment | 33 | - pressure clips |
| 21 | - feeding roller | 35 | - driving roller |
| 23 | - pressure spring | 41 | - lock / unlock flange lever |
| 25 | - lock / unlock lever | 45 | - label unwind holder |
| | 25a - working position | 102 | - rewinding shaft |
| | | 105 | - pressure roller |

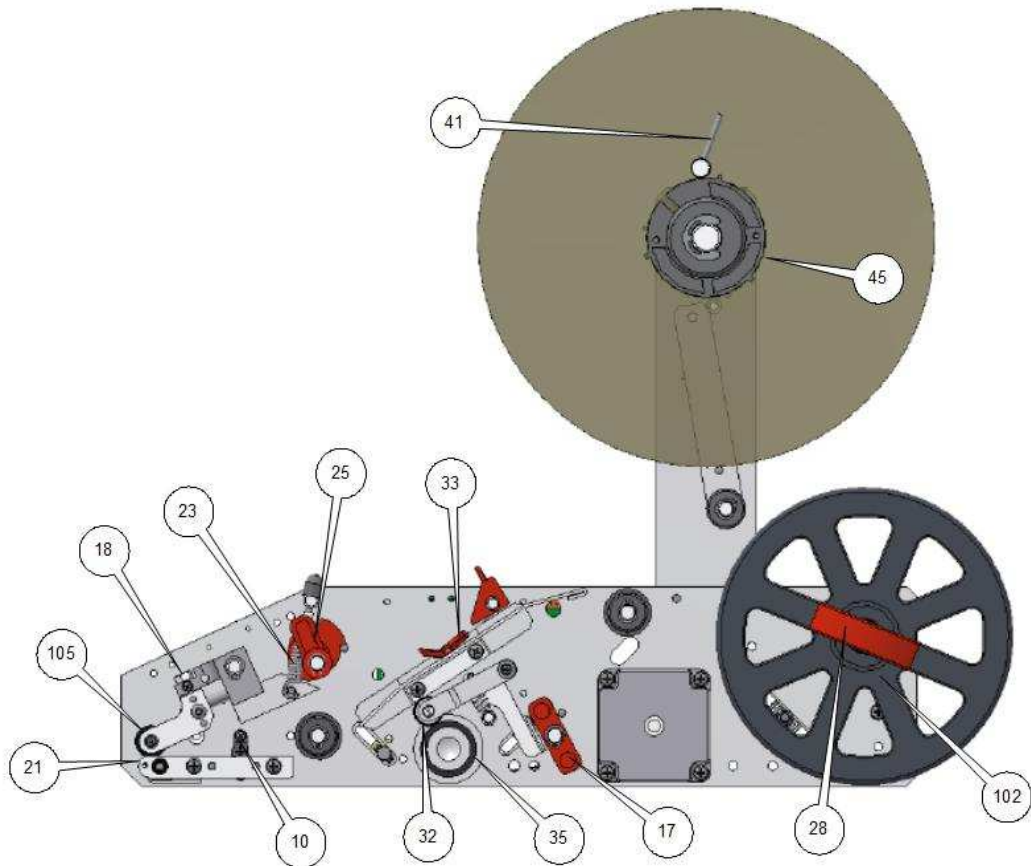

PICTURE 5

5. INCOMING INSPECTION

- * Assemble the label unwind holder support and flanges as shown in picture 6, using provided two screws and two spacers.
- * Proceed with label loading.
- * Connect the Dispenser to the Electronic Control Unit using the provided cable.
- * Check the voltage on the name plate next to the power receptacle.

- * Connect the power cable to a grounded power line
- * Switch the main switch on (rear panel)
LIGHT BLUE display ON means operating conditions.

NOTE: the Dispenser retains the label length and the baking paper transparency in permanent memory. In case of change of media see the following paragraph.

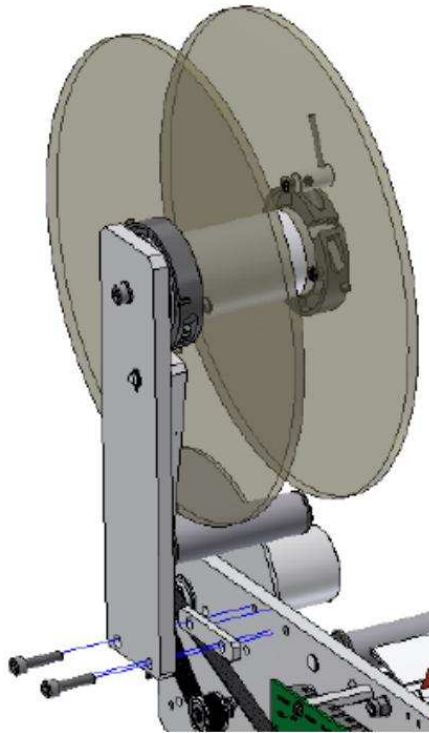

PICTURE 6

5.1. LABEL FORMAT SET UP PROCEDURE

(SEE PICTURE 5 and CHAPTER 7)

The Dispenser retains the label length and the backing paper transparency in permanent memory.

If changing label format or media type

you have to use the following procedure to update the values:

- 1 - Switch the Dispenser off.
- 2 - Lift the pressure roller up by rotating lever #25b.
- 3 - Thread the web between the feeding roller and the pressure roller #21,105.
- 4 - Lift the main pressure roller up by rotating lever #17b.
- 5 - Thread the web between the driving roller and the main

pressure roller #35,32 up to the rewinding shaft #102.

- 6 - Check web has been rightly positioned under the label photosensor #10.
- 7 - Lift the pressure roller and the main pressure roller down by rotating levers #25a and #17a.
- 8 - Switch the Dispenser on while pushing the print button #1.
- 9 - Dispenser ejects some labels (depending on their length) and stores the values of the media.
- 10 - Release the print button #1.
- 11 - The display lights blue and the Dispenser is ready to work.

6. LABEL ROLL REPLACEMENT

(SEE PICTURE 5)

In case of changing of label format or media type, remember to follow the "Label format set up procedure".

Remove the movable flange by rotating the lever #41.

Remove the empty label roll.

Insert new label roll onto roller #45

Reassemble the movable flange and push it tightly against the side of the label roll; lock lever #41.

By rotating the lever #17b, lift the main pressure roller #32 from the driving roller #35.

By rotating the lever #25b, lift the pressure roller #105 from the driving roller #21.

Remove clip #28 from the rewinding shaft #102.

Remove backing paper from the rewinding shaft.

Remove the first 50 centimetres from liner of the new roll labels.

Hold pressure clip #33 up and feed the liner through the path, then around the main driving roller and

under the pressure roller #35,32, finally slide the liner on the rewinder unit #102 and fasten it with the clip holder #28.

Turn the rewinder to stretch the paper.

Turn toggle levers back to closed positions 25a and 17a.

Check paper has been rightly positioned under the label photosensor #10.

Check pressure clips #33 has been positioned between centre and outer side of the label.

Check paper has been rightly positioned under the label photosensor #10.

Check pressure clip #33 has been positioned between centre and outer side of the label.

WARNING: Italora Dispenser mechanisms must operate only in peel-off mode with backing paper rewound by toggle lever rollers. Any other print mode (strip form, tear-off, etc.) is not allowable and cause an incorrect paper feeding.

7. PARAMETERS SETTING, DISPLAY AND KEYBOARD

7.1. KEYBOARD

The Dispenser behaviour in response to the keyboard use depends on the current status of the Dispenser itself.

Power-ON

Features available at Dispenser Switching-ON.

NB: hold down corresponding key while switching on the Dispenser.

(release the key only after the activation of the desired function)



Press and hold the key on the front panel of the Dispenser

Switch on the Dispenser (and release the key previously pressed)

- "Power-ON" keypress procedure -

- Print/OK
 - Run the Dispenser "Initializing Procedure" (detect Label length and Media transparency)
- Menu
 - Access the Dispenser "Setup Menu" before it reaches the Standard operating mode

Standard Operating Mode (Ready / Data Receiving)

Features available when the Dispenser is in Standard operating mode ("Ready").

(Dispenser Name)
Ready!

- "Ready" Display message -

- Print/OK
 - Peels a Label
- RIGHT Arrow
 - Access the Dispenser "Quick Menu"
(refer to "Quick Menu" paragraph)
- LEFT Arrow
 - Access the Dispenser "Quick Menu"
(refer to "Quick Menu" paragraph)
- Menu
 - Access the Dispenser "Setup Menu"
(refer to "Setup Menu" paragraph)
- Pause
 - Enable/Disable the execution of the "Apply Equipment Cycle" stored in Dispenser memory
(available only on models with Apply Equipment / "OEM Expansion Board")
- "UP Arrow + DOWN Arrow" (simultaneous pressure)
 - Run the Dispenser "Reset Procedure"
 -

Quick Menu

The Dispenser "Quick Menu" allows to immediately manage the 3 basic operating parameters:

- Gap ("Y" Alignment at Peeling End)
- Delay (Peeling Delay)
- Speed (Peeling Speed)

The pressure of the "RIGHT Arrow"/"LEFT Arrow" keys admit to browse the Dispenser "Quick Menu" as shown:

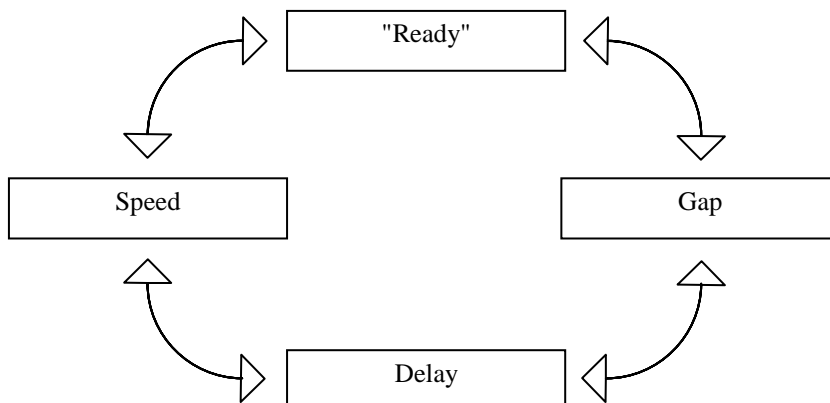

Features available in the Dispenser "Quick Menu":

- RIGHT/LEFT Arrows
 - Scroll Menu
- UP/DOWN Arrows
 - Increase/Decrease displayed parameter

- Print/OK
 - Store the displayed Option and return to the "Ready" operating condition
- Esc
 - Exit Menu and return to the "Ready" operating condition

WARNING: to really change the value of any parameter, the "Print/OK" key should be pressed!!
 Transferring to another Item ("RIGHT/LEFT Arrows") or exiting the Menu ("ESC" key) without pressing the "Print/OK" key will NOT STORE the setting of the parameter previously displayed!!
 In this case, the settings of the last properly performed storing operation will be kept as valid.
 Each press of the "Print/OK" key stores the value of the currently displayed parameter.

Setup Menu

Features available in the Dispenser "Setup Menu".

- RIGHT/LEFT Arrows
 - Scroll Menu and Submenus Items
- UP/DOWN Arrows
 - Scroll available Options for each Item in Menu and Submenus
 - Increase/Decrease numeric fields in the Options
- Print/OK
 - Access Submenus (when the message "OK to Enter" is shown)
 - Store the displayed Option
- Esc
 - Exit Submenus and return to the previous Menu/Submenu
 - Exit Menu and return to the "Ready" operating condition

WARNING: to really change the value of any Option, the "Print/OK" key should be pressed!!
 Transferring to another Item ("RIGHT/LEFT Arrows") or exiting the Submenu/Menu ("ESC" key) without pressing the "Print/OK" key will NOT STORE the setting of the Option previously displayed!!
 In this case, the settings of the last properly performed storing operation will be kept as valid.
 Each press of the "Print/OK" key stores the value of the currently displayed Option.

Special Combos

The special combos are keys combinations (starting from "Ready" operating condition) that should be used to access some special features.

Debug Menu

This combo give access to the "Debug Menu", feature that allows to analyze the internal settings of the Dispenser and (eventually) the external interfacing signals.

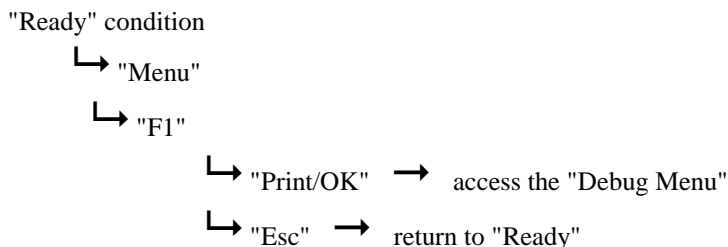

Available features inside the "Debug Menu" of the Dispenser:

- RIGHT/LEFT Arrows
 - Scroll Menu and Submenus Items
- UP/DOWN Arrows
 - Scroll available Options for "Output Commands" ("ON" or "OFF")
- Pause
 - Suspend/Resume reading "Internal Sensors"

- Suspend/Resume reading "Input Signals"
- Print/OK
 - Access Submenus (when the message "OK to Enter" is shown)
 - Run the displayed procedure (when the message "OK to START!" is shown)
 - Resume reading "Internal Sensors" from Pause condition
 - Resume reading "Input Signals" from Pause condition
 - Perform the selected Option for "Output Commands"
- Esc
 - Exit Submenus and return to the previous Menu/Submenu
 - Exit the Menu and return to the "Ready" operating condition

Setup Menu

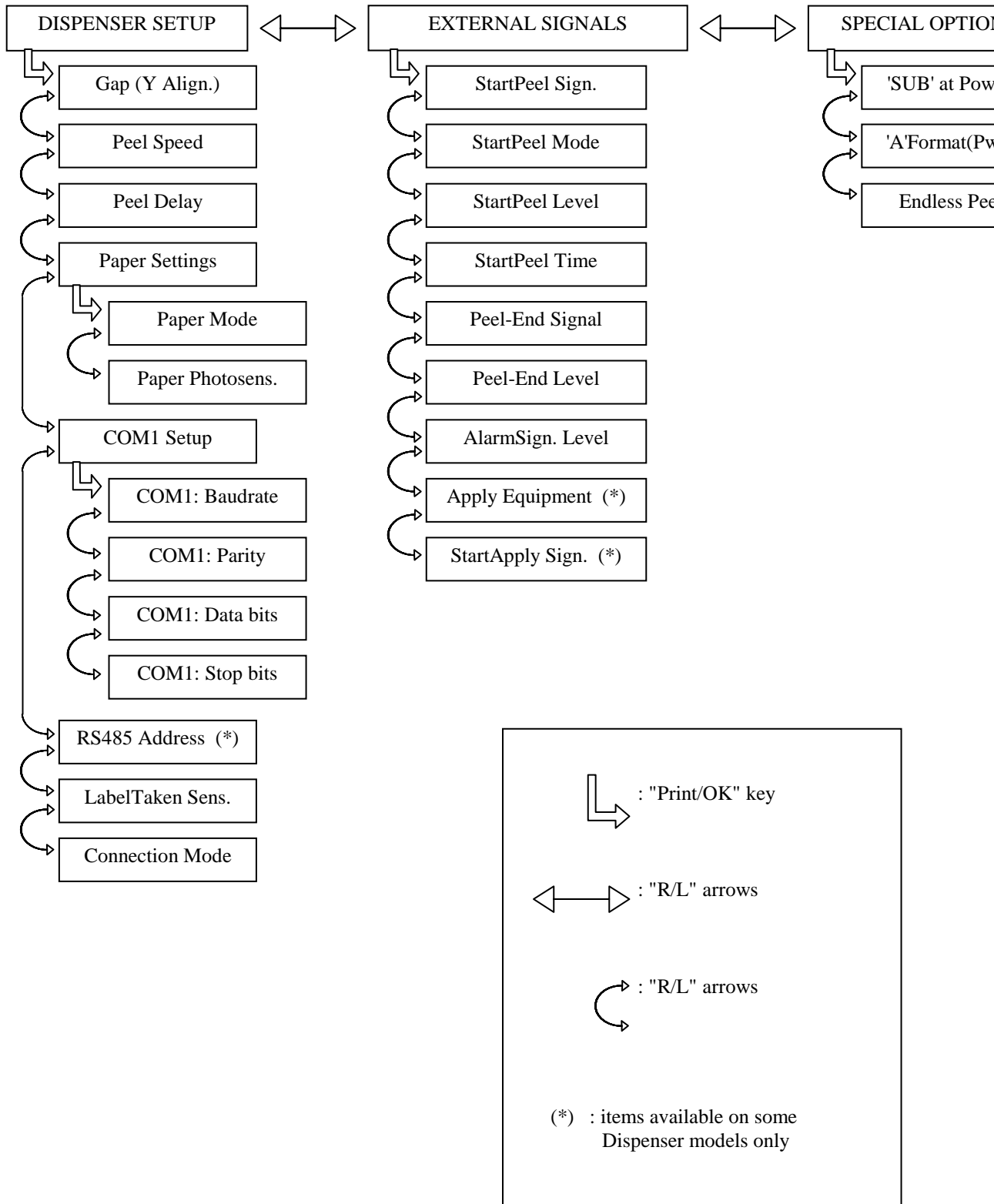

The "Setup Menu" allows to manage Dispenser operating general settings and parameters.

Available settings are divided into the following Submenus:

- DISPENSER SETUP
Dispenser operating parameters
- EXTERNAL SIGNALS
External Signals management
- SPECIAL OPTIONS
special Dispenser operating modes

DISPENSER SETUP

"Dispenser Setup" Submenu contains the following Items:

- Gap (Y Align.)
Set the alignment "Gap" at peeling end
- Peel Speed
Set the Dispenser peeling speed
- Peel Delay
Set the Dispenser peeling delay
- Paper Settings
Media management:
 - Paper Mode
Media typology:
 - Labels: stickers/adhesive labels
 - Continuous: continuous media without marking signs
 - Tag/Tickets: media with marking signs or holes
 - Paper Photosens.
Media photosensor typology:
 - Fork
 - Reflection
- COM1 Setup
Serial communication settings for "COM1" Port
 - COM1: BAUDRATE
 - COM1: PARITY
 - COM1: DATA bits
 - COM1: STOP bits
- RS485 Address (available on "RS485" models only)
Dispenser address for communication on "RS485" protocol
- LabelTaken Sens.
Use/Presence of Label-Taken Sensor
- Connection Mode
Control Characters receiving mode
 - Standard: received Control Characters are not modified
 - Mainframe: conversion of all Control Characters received in the "Carriage Return" character (CR, ASCII code = 13)

EXTERNAL SIGNALS

"External Signals" Submenu contains the following Items:

- StartPeel Sign.
Enable/Disable Start-Peel Signal
- StartPeel Mode
Start-Peel Signal operating mode selection
- StartPeel Level
Set the Start-Peel Signal logic level of activation
- StartPeel Time
Set the Start-Peel Signal minimum period
- Peel-End Signal
Peel-End Signal operating mode selection
- Peel-End Level
Set the Peel-End Signal logic level of activation
- AlarmSign. Level
Set the Alarm Signal / Auxiliary Out logic level of activation
- Apply Equipment (available on "OEM Expansion Board" models only)
Enable/Disable the execution of the "Apply Equipment Cycle"

- StartApply Sign. (available on “OEM Expansion Board” models only)
Enable/Disable Start-Apply Signal

SPECIAL OPTIONS

"Special Options" Submenu contains the following Items:

- 'SUB' at PowerON
Send of "SUB" character (by the Dispenser) every time the power is restored (eg: at Power-ON or in case of voltage drops)
- 'A'Format(PwrON)
Management of the "Label 'A' Format" auto-activation at Power-ON
- Endless Peeling
Endless Peeling operating mode:
continuous Labels peeling

Debug Menu

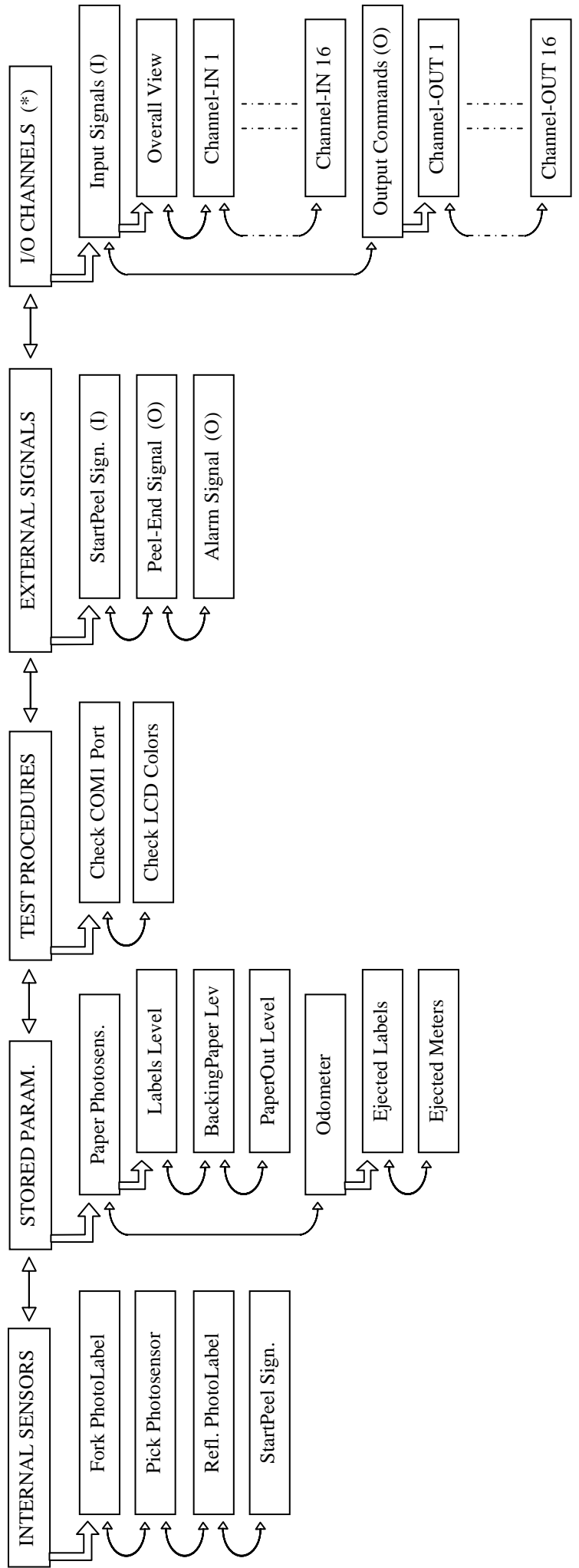
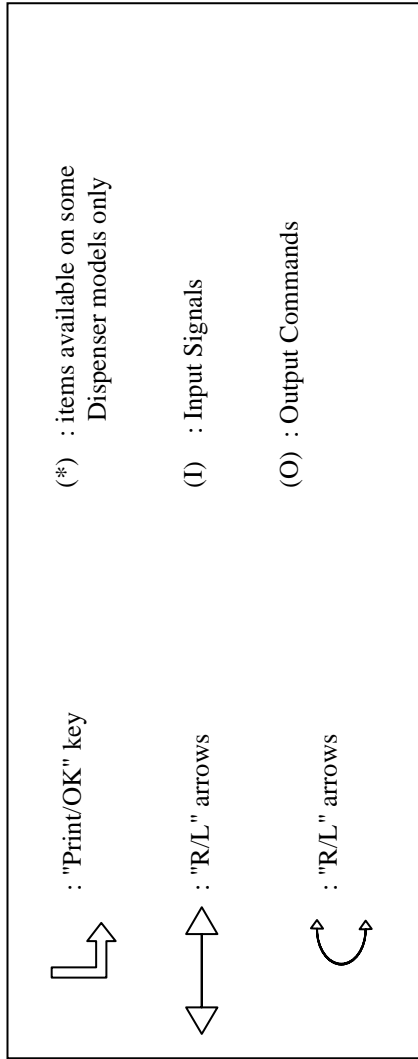

The "Debug Menu" allows to monitor and analyze Dispenser settings and (eventually) the external interfacing signals, in order to identify and solve any faults or malfunctioning.

Available settings are divided into the following Submenus:

- **INTERNAL SENSORS**
Dispenser Internal Sensors interrogation
- **STORED PARAM.**
displaying of parameters related to Media transparencies and made/performed Peeling
- **TEST PROCEDURES**
procedures to test some Dispenser features
- **EXTERNAL SIGNALS**
External Control Signal analysis
- **I/O CHANNELS** (available on "OEM Expansion Board" models only)
Input Signals and Output Commands analysis

INTERNAL SENSORS

- Fork PhotoLabel: value read from Print Media Photosensor (Fork type)
- Pick Photosensor: value read from Label-Taken Photosensor
- Refl. Photolabel: value read from Print Media Photosensor (Reflection type)
- StartPeel Sign.: Start-Peel Signal value

STORED PARAM.

- o Paper Photosens.
Media transparencies, stored during the last alignment procedure:
 - Labels Level: boundary value of labels detection
 - BackingPaper Lev: boundary value of backing-paper detection
 - PaperOut Level: boundary value of End-Media detection
- o Odometer
parameters related to made/performed Peeling:
 - Ejected Labels: number of peeled labels
 - Ejected Meters: amount of ejected Media

TEST PROCEDURES

- o Check COM Port
serial communication check procedure (available for "COM1" Port only)
- o Check LCD Colors
8-color LCD Display check procedure

EXTERNAL SIGNALS

- StartPeel Sign.: Start-Peel Signal status
- Peel-End Signal: Peel-End Signal management
- Alarm Signal: Alarm Signal / Auxiliary Out management

I/O CHANNELS

(available on "OEM Expansion Board")

- o Input Signals
reading of the 16 Input Signals ("Channel-IN")
- o Output Commands
management of the 16 Output Commands ("Channel-OUT")

7.2. MEANING OF DISPLAY COLOURS

The Dispenser display can use different background colours. The meaning of these colours is the following:

- Light Blue:
 - "Ready" operating condition
- Red:
 - Error/Alarm condition due to factors external to the Dispenser (need for direct Operator intervention to identify and solve the problem)
- Blue:
 - browsing the Printer "Setup Menu"
- Violet:
 - browsing the "Debug Menu"
- Dark Blue:
 - Printer busy/engaged in internal procedures
 - Pause status while reading "Internal Sensors" (Debug mode)
 - Pause status while reading "Input Signals" (Debug mode)
- Green:
 - "Ready" operating condition when the execution of the "Apply Equipment Cycle" is enabled. (available on "OEM Expansion Board" models only)
- Yellow/Green blinking:
 - need for Operator intervention to restart Dispenser (when the message "Turn OFF/ON to do" is shown)

8. INTERFACING

8.1. SERIAL INTERFACE

- Electronic Control Units for **Dispensers** have a RS232 hardware interface. Provided on board connector is a Cannon 9 pins "DB" female cabled as shown in the following pictures.
- **RS232 – DB9 CONNECTOR**
- Connector pinout is

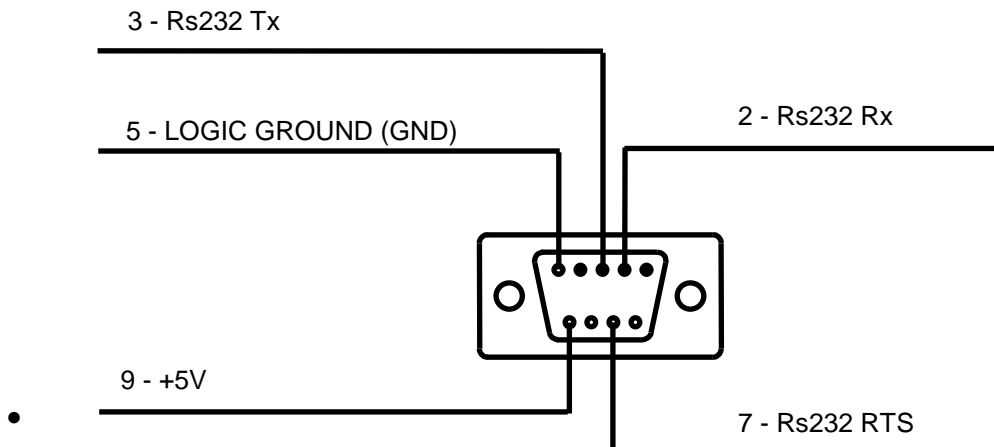

- Connection to personal computer may be done in different ways:

COMPUTER CONNECTOR - 9 PIN		COMPUTER CONNECTOR - 25 PIN	
COMPUTER	PRINTER	COMPUTER	PRINTER
2	3 TX	3	3 TX
3	2 RX	2	2 RX
8	7 RTS	5	7 RTS
5	5 GND	7	5 GND

COMPUTER CONNECTOR: -using sw protocol XON/XOFF: short together PINS 7-8 and 1-4-6.		COMPUTER CONNECTOR: -using sw protocol XON/XOFF: short together PINS 4-5 and 6-8-20.	
-using hw protocol CTS/RTS: short together PINS 1-4-6.		-using hw protocol CTS/RTS: short together PINS 6-8-20.	

8.2. I/O SIGNALS

Wiring for I/O signals 6 poles DIN connector

Pick & Place working mode allows an external device (i.e. PLC, photocell, pneumatic applicator, etc...) to start or halt printing.

When Pick & Place options is enabled 3 optoisolated signals are available:

START PRINT
PRINT END
ALARM

Input – print consent
Output – print end signal
Output – auxiliary output for error conditions

These 3 signals are mapped on a 6 poles DIN tap.
DIN plug has following outline:

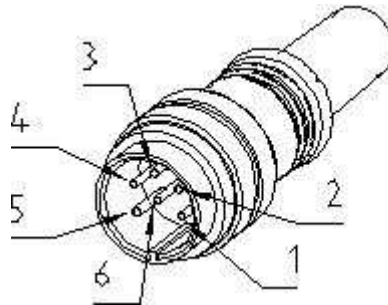

External view

Wiring for I/O signals 3,4 and 5 poles connectors

Pick & Place working mode allows an external device (i.e. PLC, photocell, pneumatic applicator, etc...) to start or halt printing.

When Pick & Place options is enabled 3 optoisolated signals are available:

START PRINT
PRINT END
ALARM

Input – print consent
Output – print end signal
Output – auxiliary output for error conditions

Devices with I/O expanded control unit, internale +24V supply and ground have these 3 signals mapped, besides on a 6 poles female connector, also on a 3,4 and 5 poles male connector .
See details ahead in these pages.

Pin out for Electronic Unit without expansion board - External power supply and ground

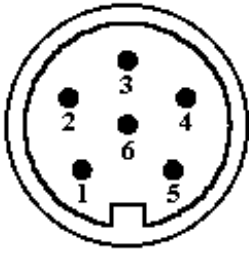

- 1) + START PRINT (INPUT)
- 2) - START PRINT (INPUT)
- 3) + ALARM (OUTPUT)
- 4) - ALARM (OUTPUT)
- 5) + PRINT END (OUTPUT)
- 6) - PRINT END (OUTPUT)

DIN plug
Internal view, soldering side

Pin out for Electronic Unit without expansion board - Internal power supply and ground

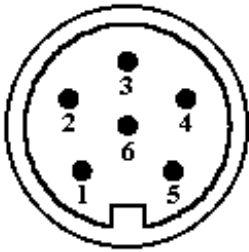

- 1) + START PRINT (INPUT)
- 2) - START PRINT (INPUT)
- 3) +24/20/10,5 V
- 4) GND
- 5) + PRINT END (OUTPUT)
- 6) - PRINT END (OUTPUT)

DIN plug
Internal view, soldering side

Pin out for Electronic Unit with expansion board – Internal +24V power supply and ground

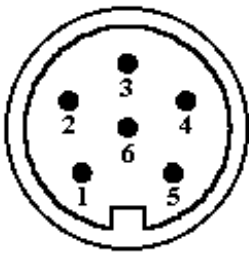

- 1) + START PRINT (INPUT)
- 2) GND
- 3) + ALARM (OUTPUT)
- 4) GND
- 5) + PRINT END (OUTPUT)
- 6) +24V

DIN plug
Internal view, soldering side

Wiring for I/O signals

Electronic Unit without expansion board

External power supply and ground

START PRINT
(soldering side view)

SWITCH

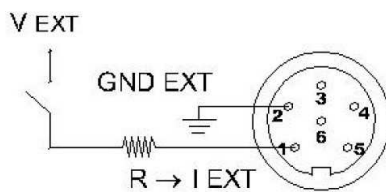

PNP Photocell

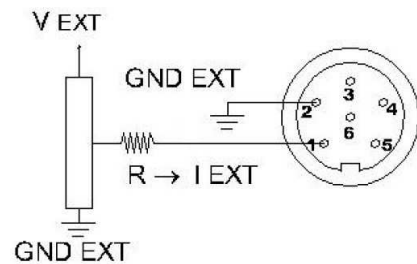

Input signal

Vext = external tension
Iext = current on external circuit
R = external circuit resistance

Vext (Volt)	Iext (mA)	R (Ohm)
24	15	1270
24	30	470
24	50	150
12	15	470
12	30	70
5	15	0

suggested values in **bold**

ALARM and PRINT END signals
(soldering side view)

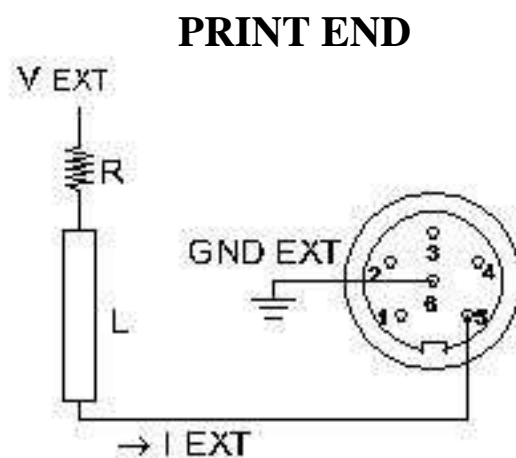
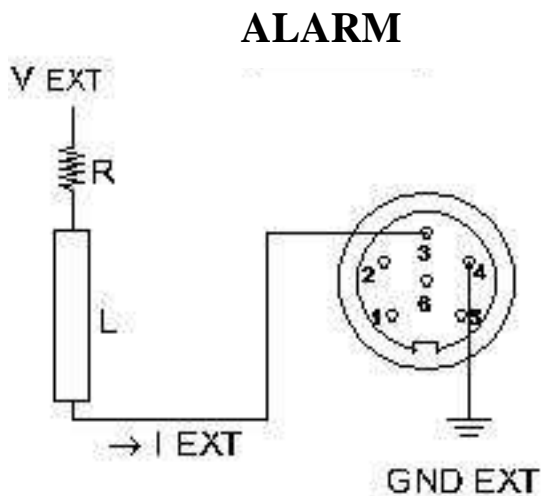

Output signals

Alarm and Print End

Vext = external tension

Iext = current on external circuit

R = Current limiting resistance of external circuit

L = Load impedance of external circuit

Vext (Volt)	Iext (mA)	R + L (Ohm)
24	10	2400
24	20	1200
24	50	240
12	10	1200
12	20	600
12	50	120
5	10	500
5	20	250
5	50	100

suggested values in **bold**

Wiring of I/O signals

Electronic Unit without expansion board

Internal power supply and ground

START PRINT
(soldering side view)

SWITCH

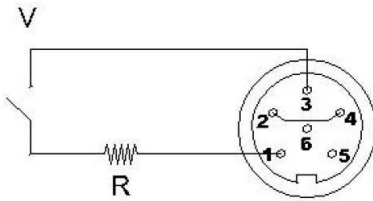

PNP Photocell

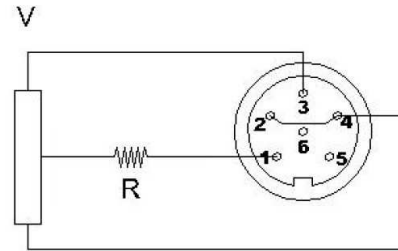

Input signal

V = Internal tension

I = current

R = external circuit resistance

V (Volt)	I (mA)	R (Ohm)
24	15	1270
24	30	470
24	50	150
12	15	470
12	30	70
5	15	0

suggested values in **bold**

PRINT END signal – ALARM signal is unavailable
 (soldering side view)

PRINT END

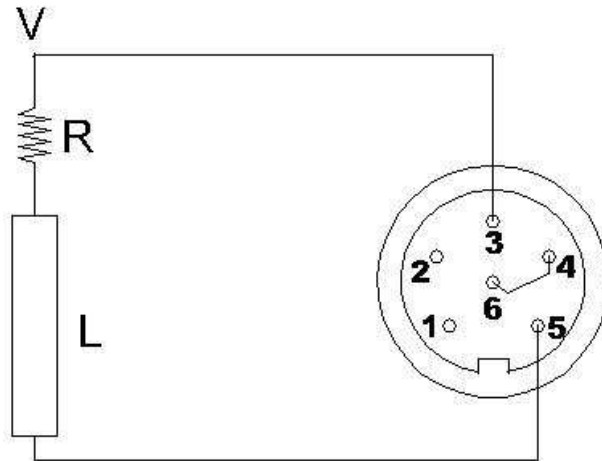

Output signal

Print End

V = external tension

I = current on external circuit

R = Current limiting resistance of external circuit

L = Load impedance of external circuit

V (Volt)	I (mA)	R + L (Ohm)
24	10	2400
24	20	1200
24	50	240
12	10	1200
12	20	600
12	50	120
5	10	500
5	20	250
5	50	100

suggested values in **bold**

Wiring of I/O signals
Electronic Unit with expansion board
+24V internal power supply and ground

START PRINT signal
(soldering side view)

SWITCH

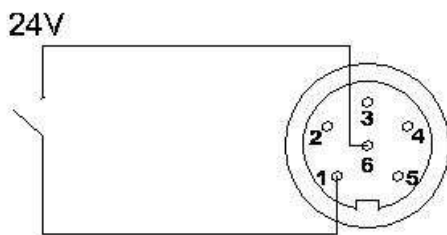

PNP Photocell

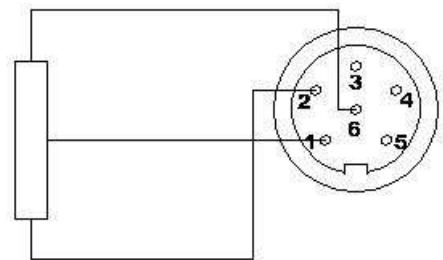

Input signal

Internal circuit resistance = 1800 Ohm

ALARM and PRINT END signals
(soldering side view)

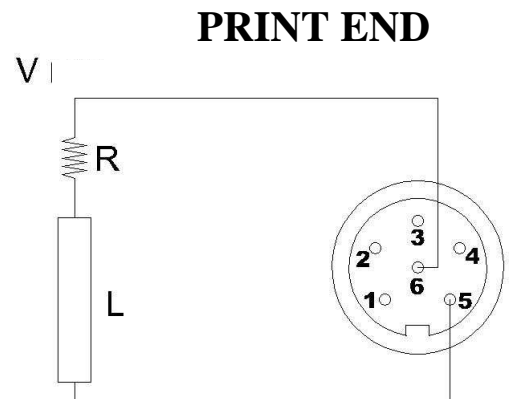
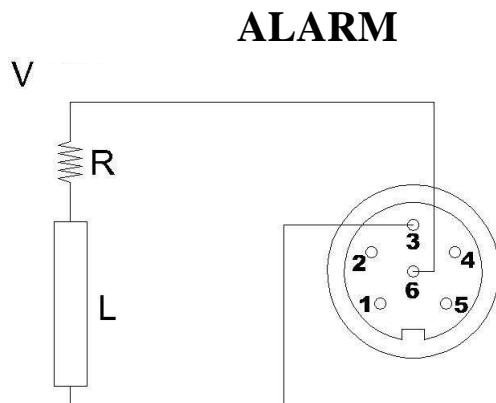

Output signals

Alarm and Print End

V = internal tension

I = current

R = Current limiting resistance of external circuit

L = Load impedance of external circuit

V = internal +24 Volt

Output transistor can drive up to 1 ampère.

$$I = V/(R+L)$$

$$I_{max} = 1A$$

V (Volt)	I (mA)	R + L (Ohm)
24	10	2400
24	20	1200
24	50	240

suggested values in **bold**

Wiring of I/O signals 3, 4 e 5 poles connectors

Devices with I/O expanded control unit, internale +24V supply and ground have these 3 signals mapped, besides on a 6 poles female connector, also on a 3,4 and 5 poles male connector .
Sockets for signal wiring have following configurations:

Pin out for Electronic Unit with expansion board – Internal +24V power supply and ground

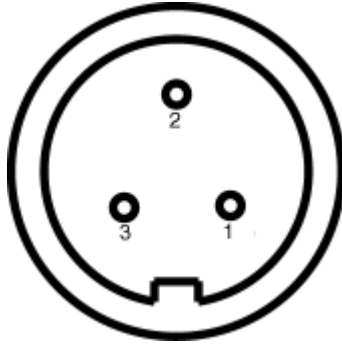

- 1) GND
- 2) +24V
- 3) INPUT - START PRINT signal

3 poles, female, START PRINT signal
Internal view, soldering side

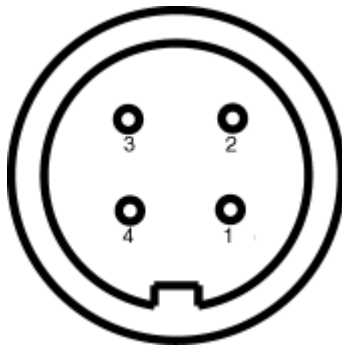

- 1) GND
- 2) +24V
- 3) OUTPUT - PRINT END signal
- 4) unused

4 poles, female, PRINT END signal
Internal view, soldering side

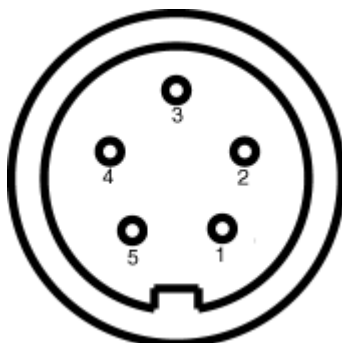

- 1) GND
- 2) +24V
- 3) OUTPUT - ALARM signal
- 4) unused
- 5) unused

5 poles, female, ALARM signal
Internal view, soldering side

START PRINT signal
(soldering side view)

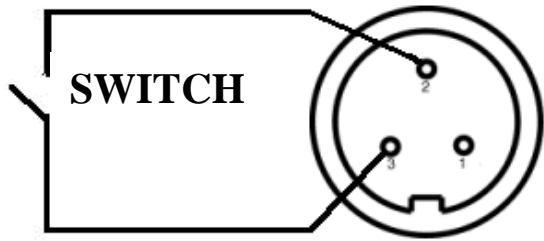

PHOTOCELL

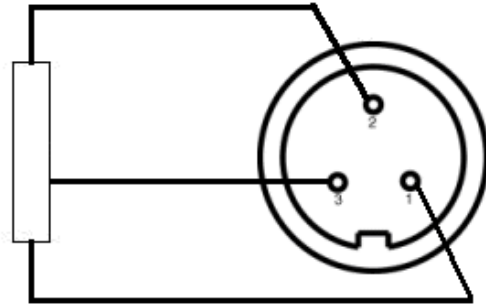

Input signal

Internal circuit resistance = 1800 Ohm

ALARM and PRINT END signals
(soldering side view)

PRINT END

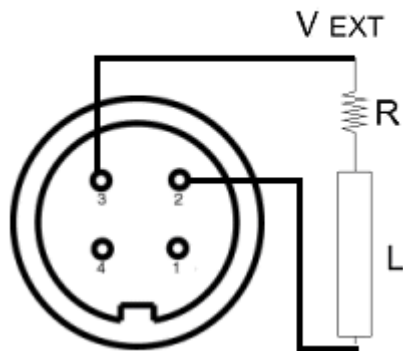

ALARM

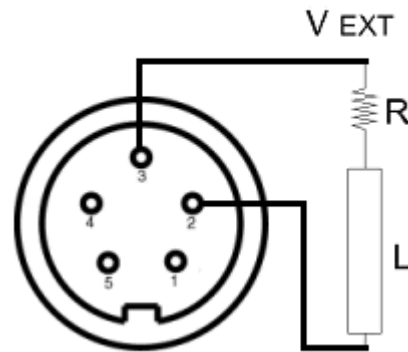

Output signals

Alarm and Print End

V = internal tension

I = current

R = Current limiting resistance of external circuit

L = Load impedance of external circuit

V = internal +24 Volt

Output transistor can drive up to 1 ampère.

$$I = V/(R+L)$$

$$I_{max} = 1A$$

V (Volt)	I (mA)	R + L (Ohm)
24	10	2400
24	20	1200
24	50	240

suggested values in **bold**

9. MAINTENANCE

WHEN NOT IN USE:

- SWITCH OFF POWER

- ALWAYS LIFT UP FEEDING ROLLER AND DRIVING ROLLER TOGGLE LEVER MECHANISMS

9.1. CLEANING

Rubber feeding and driving rolls: use alcoholic detergents.

Photosensor: use a soft brush.

Metallic and plastic parts: use a soft cloth with water-based detergent (weak).

Removing adhesive traces or parts of labels: use alcoholic detergents. Be careful the liquid does not drip on the electronic compartment.

10. TROUBLE SHOOTING

10.1. NO LABELS FEEDING

Two situations may occur.

a) Display is OFF, check (pict.1,#100):

- main voltage
- main switch (pict.1,#103) ON.
- main connector (pict.1,#104) plugged in

- main fuses (pict.1,#6) intact.

b) Display is RED, check:

- label roll is not used up.
- paper position under the photosensor (pict.5,#10)

10.2. INCORRECT LABEL ALIGNMENT

Make sure that:

- toggle levers are closed (pict.5,#17a, 25a)
- paper position under the photosensor (pict.5,#10)
- backing paper is correctly rewound (pict.5,#102)
- pressure clip (pict.5,#33) is positioned

between centre and outer side of the label.

- movable flange is tightly pushed against the side of the label roll with the lever (pic.5,#41) in lock position.

See also "Label format set up procedure".

10.3. PAPER SLIDES OUTSIDE

Check whether:

- pressure clip (pict.5,#33) is positioned between centre and outer side of the label.

- movable flange is closely positioned against the side of the label roll with the lever (pic.5,#41) in lock position.

11. HARDWARE NOTES

11.1. HOW TO CHECK ELECTRONIC BOARDS

- **First unplug the power cable from the electronic cabinet.**

- turn the 4 front and the 4 rear screws out (pict.8#114 - 121).
- remove front and rear panels.
- turn the 4 side screws out (pict.8,#122 - 125).
- turn the 3 inner screws out (pict.8,#126 - 128).
- Unplug the following connectors from CPU board (pict.21).and pull carefully off the electronic boards from the chassis

Y3 = LCD

Y4 = stepping motor

Y5 = label photosensor

Y7 = serial port

Y11 = I/O signals

Y14 = fan

Y17 = Keyboard

Y18 = LCD

Y29 = USB

Y30 = power supply

- disconnect the ground cable turning the chassis nut out

- unplug the fuses connectors and the main switch connector.



PICTURE 8

11.2. DRIVE BELT REPLACEMENT (SEE PICTURE 10)

Loosen the relevant idler #16 and remove the belt.
Replace the relevant belt and stretch it by the idler till

you get a deflection of 4 to 6 mm when applying a force of 6 N.

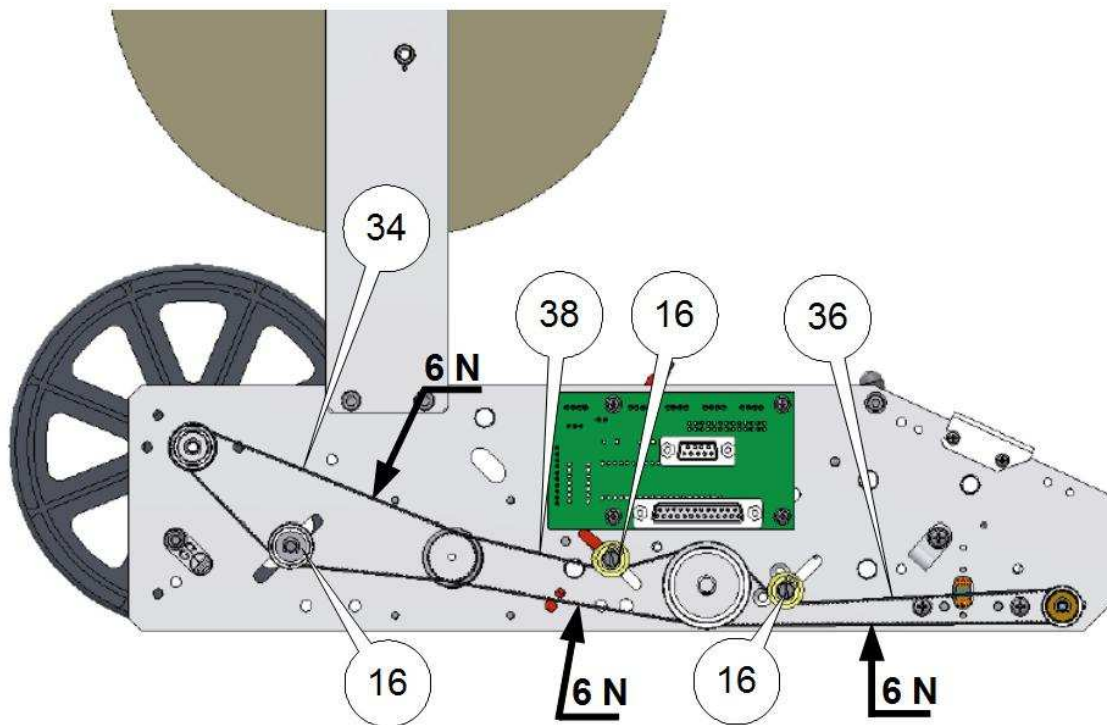

PICTURE 10

12. SCHEMES

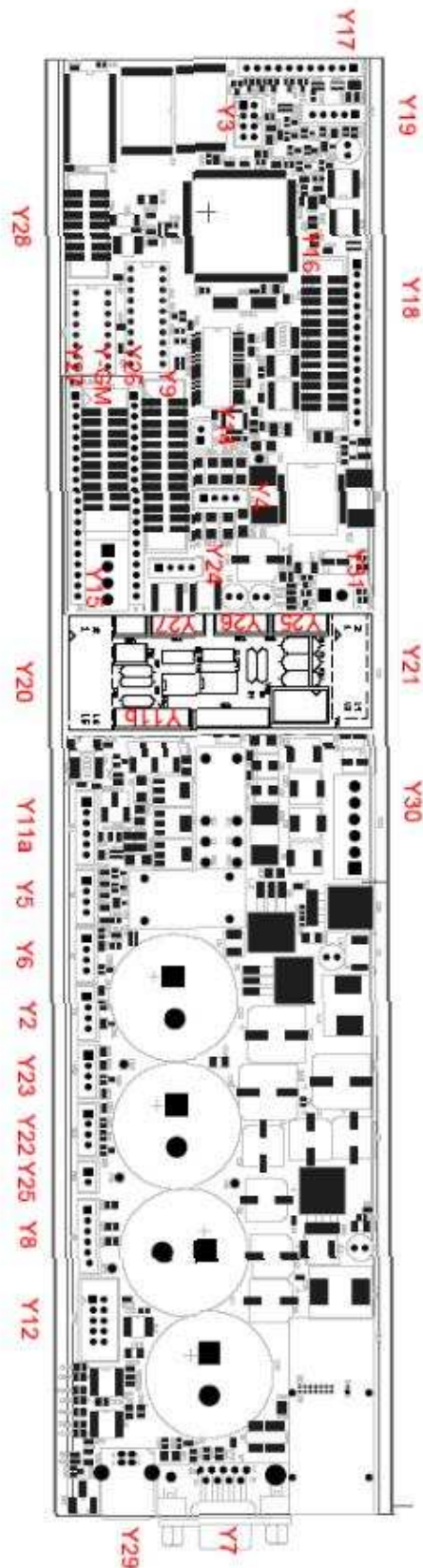

Dispenser 3" EL7

Y1	
Y2	
Y3	LCD
Y4	Motor
Y5	Label sensor
Y6	
Y7	Serial port
Y8	
Y9	
Y10	
Y11	I/O Signals
Y12	
Y13	
Y14	Fan
Y15	
YGM	
Y17	Keyboard
Y18	LCD
Y19	
Y20	
Y21	
Y22	
Y23	
Y24	
Y25	
Y26	
Y27	
Y28	
Y29	USB
Y30	Power supply

PICTURE 21 LOGIC BOARD - layout

13. PART LIST AND RELEVANT PICTURES

(items are referred to following pictures)

ITEM	PART NUMBER	DESCRIPTION	Dispenser 3" EL7
1	800822960	keyboard	*
2	801665280	DIN connector assy	*
4	801292050	filter cap	*
5	056102080	fuse 2A T	*
6	056102020	fuse 1.6A T	*
7	801292090	fuse holder	*
9	056102030	fuse 28 T	*
10	809065080	label photosensor assy	*
11	800943880	display assy	*
12	059006010	cable 25 pins, 1000 mm	*
13	800944080	power supply	*
15	80087700015	CPU board	*
16	800925310	belt idler assy	*
17	80076209002	lever	*
18	801312400	nut	*
19	800925620	plate	*
20	80087217001	connection board (Dispenser)	*
21	800722440	feeding roller	*
22	801312220	pulley	*
23	800742100	spring	*
24	800542370	peeling plate	*
25	800925880	lever cam	*
26	800928870	pressure roller	*
27	809032200	spring	*
28	800762340	clip holder 2"	*
30	809060103	belt idler assy	*
31	800872180	connection board (electronic cabinet)	*
32	809060102	pressure group	*
33	810940029	media position holder assy	*
34	800782360	belt	*
35	800722450	driving roller	*
36	809062170	belt	*
40	800926220	fan assy 60 x 60 mm	*
41	801605260	fixed flange assy	*
43	061702050	bushing	*
44	061702070	bushing	*
45	800925690	pulley Z22	*
46	801605200	movable flange assy	*
49	800949940	stepping motor assy	*

