

DISPENSER 2”

USER MANUAL



Italora S.r.L. Largo Guastalla 7 - 20082 Binasco - (Milano) - Italy
phone ++39.02.90092074 - fax ++39.02.9055461
internet - <http://www.italora.it>
E mail - sales@italora.it

CONTENTS

1. TECHNICAL SPECIFICATIONS.....	2
2. UNPACKING	2
3. GENERAL VIEW.....	3
Dispenser 2” – overall dimensions and fitting holes	4
4. ROLLS COMPARTMENT DESCRIPTION.....	5
5. INCOMING INSPECTION	5
5.1. LABEL FORMAT SET UP PROCEDURE	6
6. LABEL ROLL REPLACEMENT.....	6
7. PARAMETERS SETTING.....	7
7.1. SPEED.....	7
7.2. GAP.....	7
7.3. DELAY	7
8. TROUBLE SHOOTING	7
8.1. NO LABELS FEEDING.....	7
8.2. INCORRECT LABEL ALIGNMENT.....	7
8.3. DRIVE BELT REPLACEMENT.....	7
9. PART LIST AND RELEVANT PICTURES.....	8

Features and specifications are subject to change without notice

DISPENSER 2”

1. TECHNICAL SPECIFICATIONS

Maximum width (label + backing paper): 60 mm

Speed: up to 350 mm/s

FEEDING

Stepping motor, size 3”, 200 steps/rev.

DETECTOR

End of paper and feeding synchronism

MEDIA

Die cut labels

LABEL SIZES

Width: 25 mm min., 60 mm max.

Length: 6 mm min., 1000 mm max.

Key: width min.: 2 mm

depth min.: 20 mm starting
from the inner edge

ROLL SIZES

Width: 25 mm min., 60 mm max.

Outer diameter: 220 mm max.

Core diameter: 45 mm min.

DIMENSIONS

See following pictures

Weights: 6 Kg (Dispenser)

7 Kg (electronic cabinet)

POWER REQUIREMENTS

Voltage: 115/230/240 Vac; 50-60 Hz

ENVIRONMENT

Operating temperature: 0°/ 40° C

Storage temperature: -20°/60° C

Humidity: 10% - 95% non-condensing

2. UNPACKING

Open the box and check the content :

- **italora Dispenser 2”**

- Electronic Control Unit cabinet

- Connection cable

- Unwind holder and flanges

- Power cable

- User manual

- Optional photocell detector

- Optional applicator

3. GENERAL VIEW

(See picture 1)

- | | | | |
|------|----------------------|--------------------------|----------------------|
| 1: | push button | 101: | status led => |
| 5: | 2 fuses 2AT (main) | - lit green: | ON-LINE |
| 6: | 1 fuse 1.6AT (logic) | - blinking green: | end of paper |
| 40: | fan | 103: | main switch |
| 42: | connection board | 104: | power cord plug |
| 44: | I/O connector | | |
| 100: | red led => | | lit at POWER ON |

Electronic Control Unit - overall dimensions and fitting holes

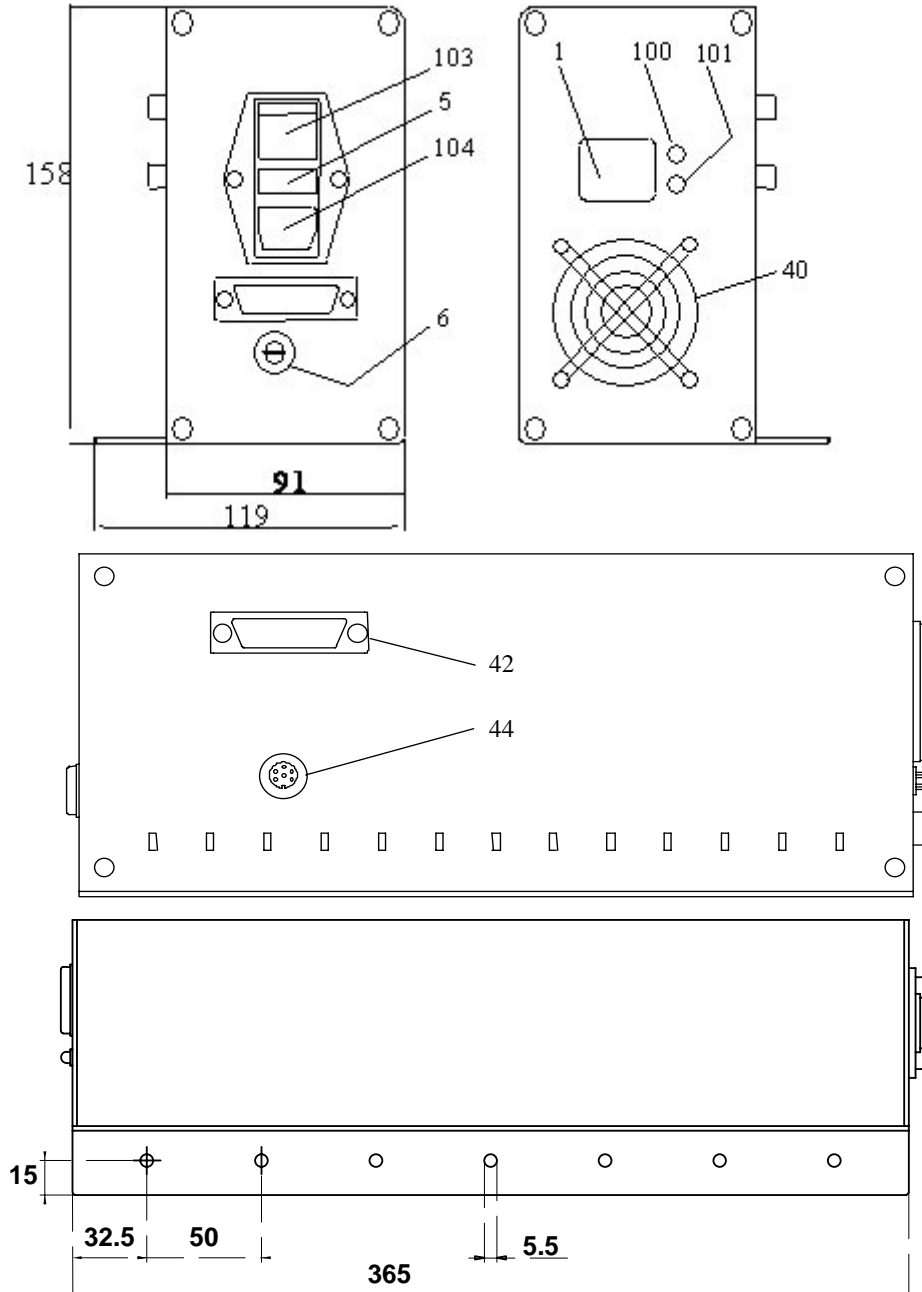

PICTURE 1

Dispenser 2'' – overall dimensions and fitting holes

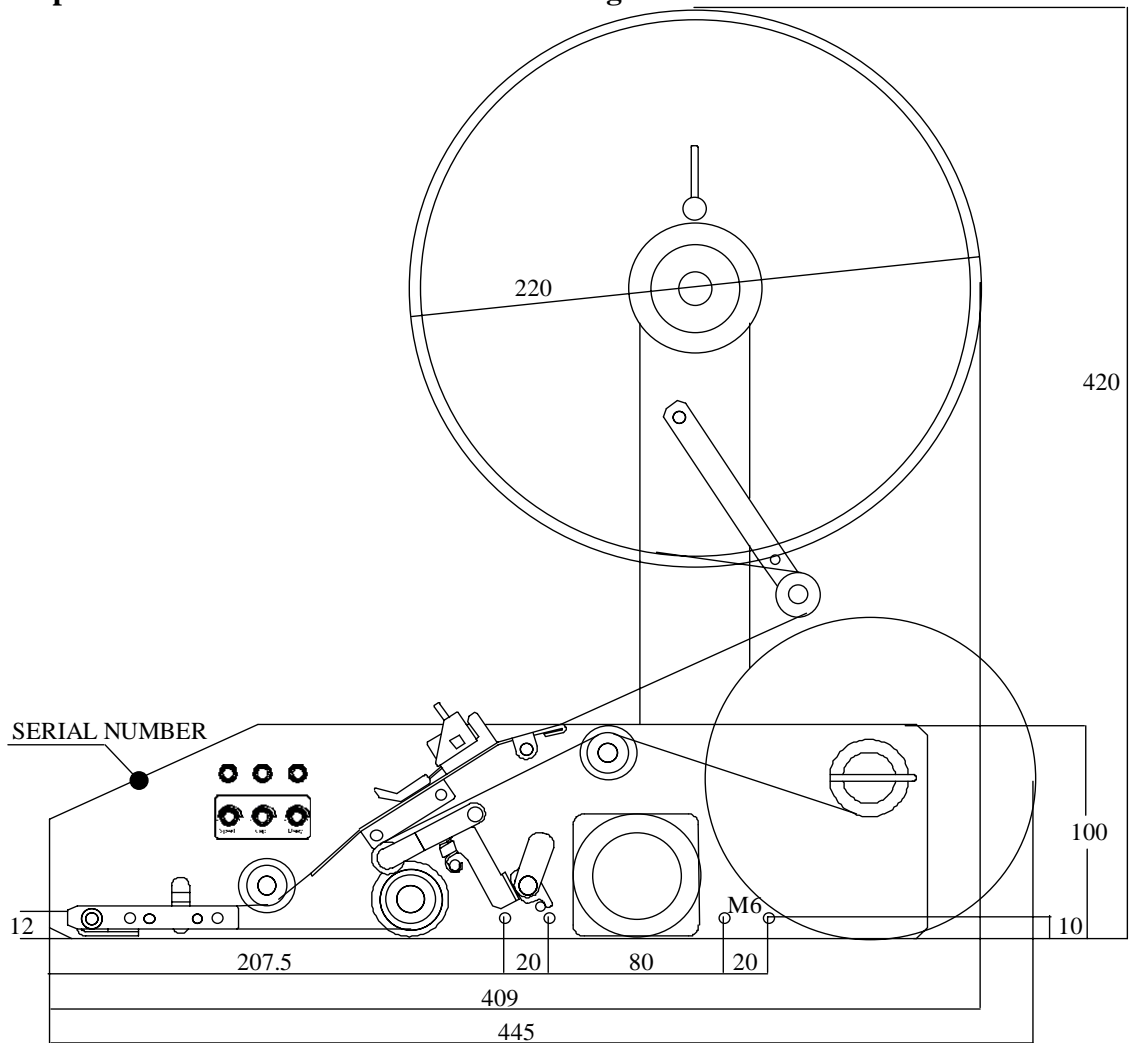

PICTURE 2 (side view)

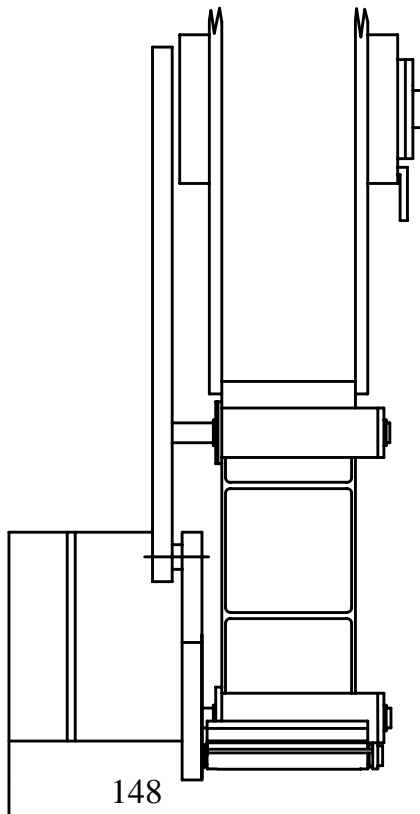

PICTURE 3 (front view)

4. ROLLS COMPARTMENT DESCRIPTION

(SEE FOLLOWING PICTURES)

- | | | | |
|----|---|-----|--|
| 10 | - photosensor for end of roll and label synchronisation | 35 | - driving roller |
| 17 | - lock / unlock toggle lever
17a - working position
17b - open position | 41 | - lock / unlock flange lever |
| 32 | - pressure roller | 43 | - potentiometers for feeding adjusting (see chapter 7) |
| 33 | - pressure clip | 45 | - label unwind holder |
| | | 102 | - rewinding shaft with adjusting clutch |

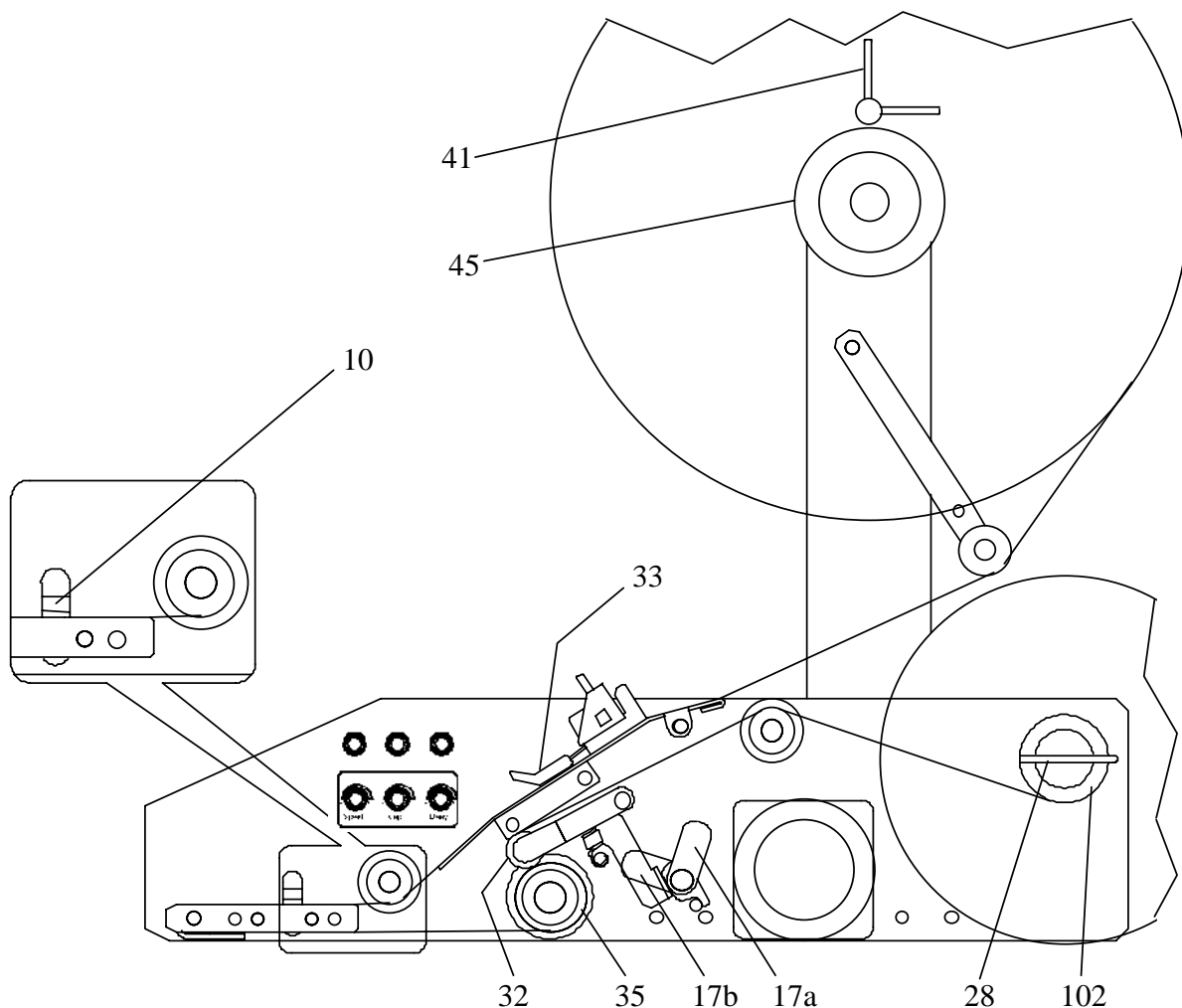

PICTURE 5

5. INCOMING INSPECTION

- * Assemble the label unwind holder support and flanges as shown in picture 6, using provided two screws and two spacers.
- * Proceed with label loading.
- * Connect the Dispenser to the Electronic Control Unit using the provided cable.
- * Check the voltage on the name plate next to the power receptacle.
- * Connect the power cable to a grounded power line

- * Switch the main switch on (rear panel)
RED and GREEN leds ON mean operating conditions.

NOTE: the Dispenser retains the label length and the baking paper transparency in permanent memory. In case of change of media see the following paragraph.

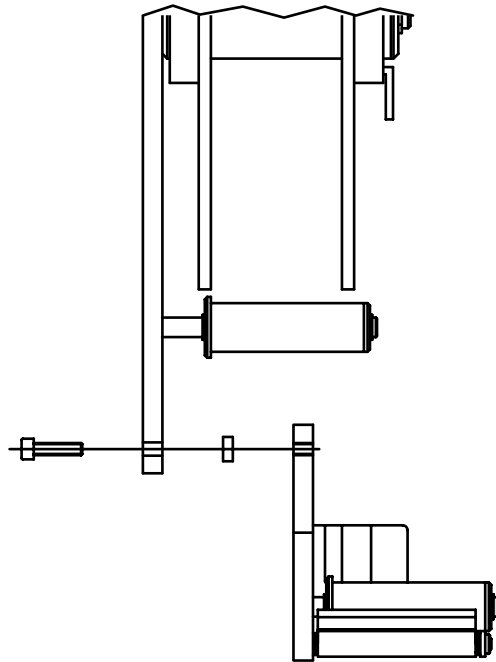

PICTURE 6

5.1. LABEL FORMAT SET UP PROCEDURE

(SEE PICTURE 5 and CHAPTER 7)

The Dispenser retains the label length and the backing paper transparency in permanent memory.

If changing label format or media type

you have to use the following procedure to update the values:

- **Switch** the Dispenser off.
- **Lift** the pressure roller up by rotating lever #17b.
- **Thread** the web between the driving roller and the pressure roller #35,32 up to the rewinding

shaft #102.

- **Check** web has been rightly positioned under the label photosensor #10.
- **Switch** the Dispenser on while pushing the button #1.
- **Dispenser** ejects some labels (depending on their length) and stores the values of the media.
- **Release** the button #1.

6. LABEL ROLL REPLACEMENT

(SEE PICTURE 5)

In case of changing of label format or media type, remember to follow the "Label format set up procedure".

Remove the movable flange by rotating the lever #41.

Remove the empty label roll.

Insert new label roll onto roller #45

Reassemble the movable flange and push it tightly against the side of the label roll; lock lever #41.

By rotating the lever #17b, lift the pressure roller #32 from the driving roller #35.

Remove clip #28 from the rewinding shaft #102.

Remove backing paper from the rewinding shaft.

Remove the first 50 centimetres from liner of the new roll labels.

Hold pressure clip #33 up and feed the liner through the path, then around the driving roller and under the pressure roller #35,32, finally slide the liner on the rewinder unit #102 and fasten it with the clip holder #28.

Turn the rewinder to stretch the paper.

Turn toggle lever back to closed positions 17a.

Check paper has been rightly positioned under the label photosensor #10.

Check pressure clip #33 has been positioned between centre and outer side of the label.

7. PARAMETERS SETTING

(SEE PICTURE 7)

Three parameters can be varied by means of potentiometers as shown on picture 7.

7.1. SPEED

Feeding speed of labels can be varied from 50 to 350 mm/s just turning relevant potentiometer, next label will be ejected at a different speed. This adjusting is very useful to synchronize label-feeding speed to conveyor speed.

7.2. GAP

To get the right peel-off position of labels (in function of label length, space between labels, applicator position, etc.), the point where the label stops can be varied rotating relevant potentiometer. Peel off position can be adjusted from -39 mm to +39 mm following a simple procedure: turn potentiometer, push the orange button positioned on the front panel of Electronics Box, same labels will be ejected reaching the new GAP value and as a consequence the new peel off position.

7.3. DELAY

The ejection of labels is driven by a signal coming from the external photocell when a tray or a box is intercepted by its light beam, the signal comes into the electronic control box and then a command is given to the Dispenser to eject a label. Delay between intercepting signal and eject command can be varied from 0 to 5 seconds just turning relevant potentiometer. This adjusting is very useful for an easy and convenient positioning of the photocell and to synchronize tray/box passing to tray/box labelling

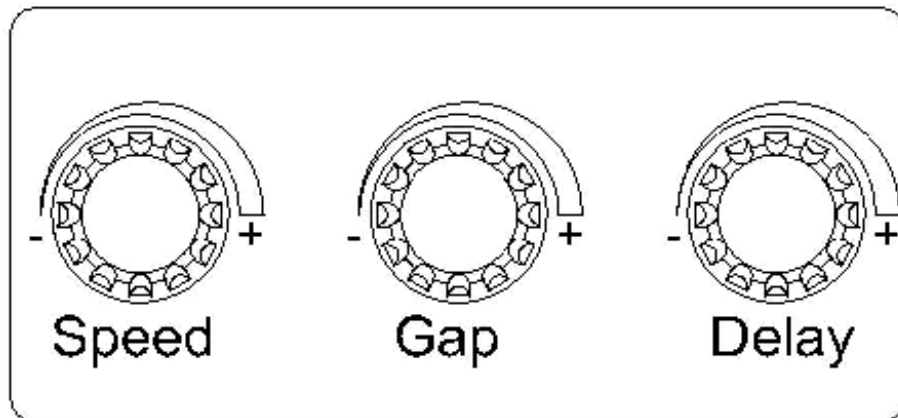

PICTURE 7

8. TROUBLE SHOOTING

8.1. NO LABELS FEEDING

Following situations may occur.

a) RED led is OFF, check (pict.1,#100):

- main voltage
- main switch (pict.1,#103) ON.
- main connector (pict.1,#104) plugged in

- main fuses (pict.1,#6) intact.

b) RED led is ON, STATUS led is BLINKING GREEN, check:

- label roll is not used up.
- paper position under the photosensor (pict.5,#10)

8.2. INCORRECT LABEL ALIGNMENT

Make sure that:

- toggle lever is closed (pict.5,#17a)
- paper position under the photosensor (pict.5,#10)
- backing paper is correctly rewound (pict.5,#102)
- pressure clip (pict.5,#33) is positioned

between centre and outer side of the label.

- movable flange is tightly pushed against the side of the label roll with the lever (pic.5,#41) in lock position.

See also "Label format set up procedure".

8.3. DRIVE BELT REPLACEMENT

(SEE PICTURE 8)

Remove the connection board and the safeguard plate from the spine, then loosen the relevant idler #16 and remove the belt. Replace the relevant belt and stretch

it by the idler till you get a deflection of 4 to 6 mm when applying a force of 7 N.

Reassemble the safeguard plate and the connection board.

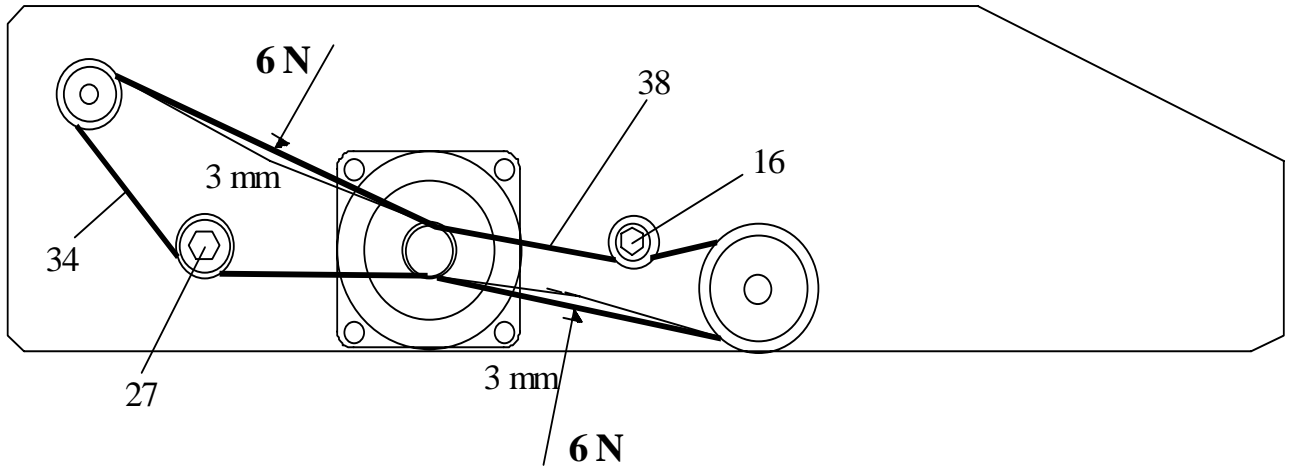

PICTURE 8

9. PART LIST AND RELEVANT PICTURES

(items are referred to following pictures)

ITEM	CODE	DESCRIPTION	Dispenser 2"
2	801665280	DIN connector assy	*
3	801292070	main switch	*
4	801292050	filter cap	*
5	056102080	fuse 2A T	*
6	056102020	fuse 1.6A T	*
7	801292090	fuse holder	*
10	809065080	label photosensor assy	*
12	059006010	cable 25 pins, 1000 mm	*
13	800945H3000	power supply	*
15	80087510215	CPU board	*
16	800925310	belt idler assy	*
17	80076209002	lever	*
20	80087217001	connection board (Dispenser)	*
22	801312220	pulley	*
24	809062150	peeling plate	*
27	809032200	spring	*
28	809062200	clip holder	*
30	809060103	belt idler assy	*
31	800872180	connection board (electronic cabinet)	*
32	809060102	pressure group	*
33	810940029	media position holder assy	*
34	800782360	belt	*
35	800925600	driving roller	*
38	800782360	belt	*
40	800926220	fan assy 60 x 60 mm	*
41	801605260	fixed flange assy	*
43	059006660	potentiometers assy	*
46	801605200	movable flange assy	*
49	800949940	stepping motor assy	*

