

**O.E.M.
THERMAL & THERMAL TRANSFER
LABEL PRINTERS**

models

AH 870 EL7

AH 871 GM EL7

AH 1271 GM EL7

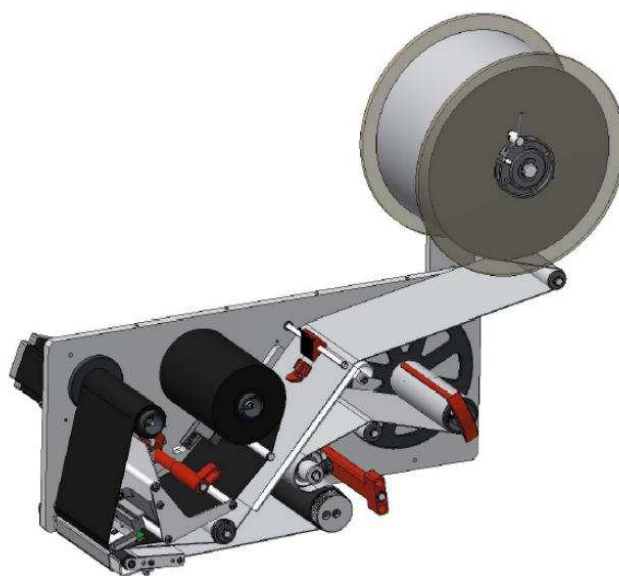

USER MANUAL

Italora

**Italora S.r.L. Largo Guastalla 7 - 20082 Binasco - (Milano) - Italy
phone +39.02.90092074 - fax +39.02.9055461**

**www.italora.it
sales@italora.it**

rev. 07.15

CONTENTS

1. TECHNICAL SPECIFICATIONS	3
2. UNPACKING	3
3. GENERAL VIEW	4
4. ROLLS COMPARTMENT DESCRIPTION	7
5. INCOMING INSPECTION	8
5.1. LABEL FORMAT SET UP PROCEDURE	9
6. PRINTING MEDIA DESCRIPTION	10
6.1. PAPER SPECIFICATIONS	10
6.2. THERMAL RIBBON SPECIFICATIONS	10
7. THERMAL RIBBON AND LABEL ROLL REPLACEMENT	10
7.1. THERMAL RIBBON REPLACEMENT	10
7.2. LABEL ROLL REPLACEMENT	11
8. PARAMETERS SETTING, DISPLAY AND KEYBOARD	11
8.1. KEYBOARD	11
8.2. MEANING OF DISPLAY COLOURS	20
9. INTERFACING	20
9.1. SERIAL INTERFACE	20
9.2. I/O SIGNALS	22
10. MAINTENANCE	33
10.1. CLEANING	33
11. TROUBLE SHOOTING	33
11.1. NO LABELS FEEDING	33
11.2. INCORRECT LABEL ALIGNMENT	33
11.3. PAPER SLIDES TO RIGHT SIDE	33
11.4. PRINTING WITH PATCHES MISSING	33
11.5. BLANK LABELS	33
11.6. POOR PRINTING CONTRAST	34
12. HARDWARE NOTES	34
12.1. HOW TO CHECK ELECTRONIC BOARDS	34
12.2. PRINT HEAD PROTECTION FUSE REPLACEMENT	34
12.3. THERMAL PRINT HEAD REPLACEMENT	34
12.4. DRIVE BELT REPLACEMENT	34
13. PICTURES	35
14. PART LIST AND RELEVANT PICTURES	40

Features and specifications are subject to change without notice

AH 870 EL7, AH 871 GM EL7 & AH1271 GM EL7 GRAPHIC LABEL PRINTERS

1. TECHNICAL SPECIFICATIONS

PRINTING

Method: Direct Thermal and Thermal Transfer
AH 870 Resolution: 8 dots/mm, 832 dots/line
Printing area: 102 x 1200 mm
Print speed: up to 150 mm/s
AH 871 GM Resolution: 8 dots/mm, 832 dots/line
Printing area: 102 x 1200 mm
Print speed: up to 300 mm/s
AH 1271 GM Resolution: 12 dots/mm, 1280 dots/line
Printing area: 108 x 500 mm
Print speed: up to 200 mm/s
X/Y positioning of texts and bar codes
Texts and bar codes printed in four orthogonal directions
Lines, diagonals, boxes, shadow and reverse printing
Graphic and logos: bit image mode
Bar Codes: EAN8, EAN13, 2/5, 2/5 I, 3/9, 2/7, DUN-14/16, UPC-A, UPC-B, UPC-E, CODE128, EAN128, Code 32, PZN, Code 93, PDF 417, Datamatrix, GS1 Databar, QR Code.

Automatic Check Digit computation
Wide/narrow ratio full programmable
Half, standard and double density
Height programmable
Suppression of human readable characters

Batch printing: up to 99.999.999 labels
Layouts: 26 programmable in Flash memory, 100 fields each
Up to 10 protection levels for variable data printing
4 up/down alphanumeric counters, 16 digits
Real Time Clock

Black intensity adjustable via SW
Print button for last label repeating

INTERFACING SIGNALS

Three optoisolated I/O

DATA TRANSFER INTERFACE

RS232/422/485: serial parameters settable by sw

USB, Ethernet (optional)

HANDSHAKE PROTOCOL

SW : XON/XOFF

HW : DTR

DATA TRANSMISSION

ASCII format

CHARACTER GENERATORS

5 fixed matrix), 6 proportionals

up to 112 customized

(see Programming Manual for further details)

Magnifications 9x9

MEMORY

32 – bit RISC microprocessor

8 MB flash

16 Mb RAM

DISPLAY: LCD alphanumeric 16 characters x 2 rows, 8 colours

KEYBOARD: 10 Keys membrane panel

DETECTORS

End of paper and feeding synchronism

End of thermal ribbon

PRINT MEDIA

Die cut labels

LABEL SIZES

Width: 30 mm min., 110 mm max

Length: 10 mm min.

1.200 mm max

Key: width min.: 2 mm

depth min.: 25 mm starting

from the inner edge

ROLL SIZES

Width: 30 mm min., 110 mm max

Outer diameter: 220 mm max

Core diameter: 45 mm min.

THERMAL RIBBON

Base polyester film, outside coated

Outer diameter: length 600 meters max

Width: 35 mm min., 110 mm max

Core diameter: 25.4 mm

PRINTER DIMENSIONS

Height: 175 mm; Depth: 452 mm

Length: 261 mm; Weight: 20 Kg

POWER REQUIREMENTS

Voltage: 115/230/240 Vac; 50-60 Hz

ENVIRONMENT

Operating temperature: 0°/ 40° C

Storage temperature: -20°/60° C

Humidity: 10% - 95% non-condensing

OPTIONS

32 digital opto-coupled I/O channels expansion boards with internal 24V power supply, Ethernet interface, Wifi interface, Label taken sensor

ETIK wysiwyg label editor Windows based

2. UNPACKING

Open the box and check the content :

- **italora** label printer model **AH 870 EL7** or **AH 871 GM EL7** or **AH 1271 GM EL7**
- Electronic Control Unit cabinet
- Connection cables
 - serial RS232, USB, DB9, DB25
- 1 DIN connector 6 poles
- unwind holder and flanges
- power cable
- roll of labels
- roll of thermal ribbon
- printing tests
- CD Rom with manuals and Etik Light

3. GENERAL VIEW

(See picture 1)

- | | | | |
|----|-----------------------------|------|----------------------|
| 1 | manual printing push button | 42 | connection board |
| 5 | 2 fuses 2AT (main) | 44 | photo cell connector |
| 6: | fuse 1.6AT (logic) | 100 | Display |
| 8A | USB connector | 103: | main switch |
| 8B | RS232 connector | 104: | power cord plug |
| 9 | fuse 8AT | | |

Electronic Control Unit overall dimensions and fitting holes

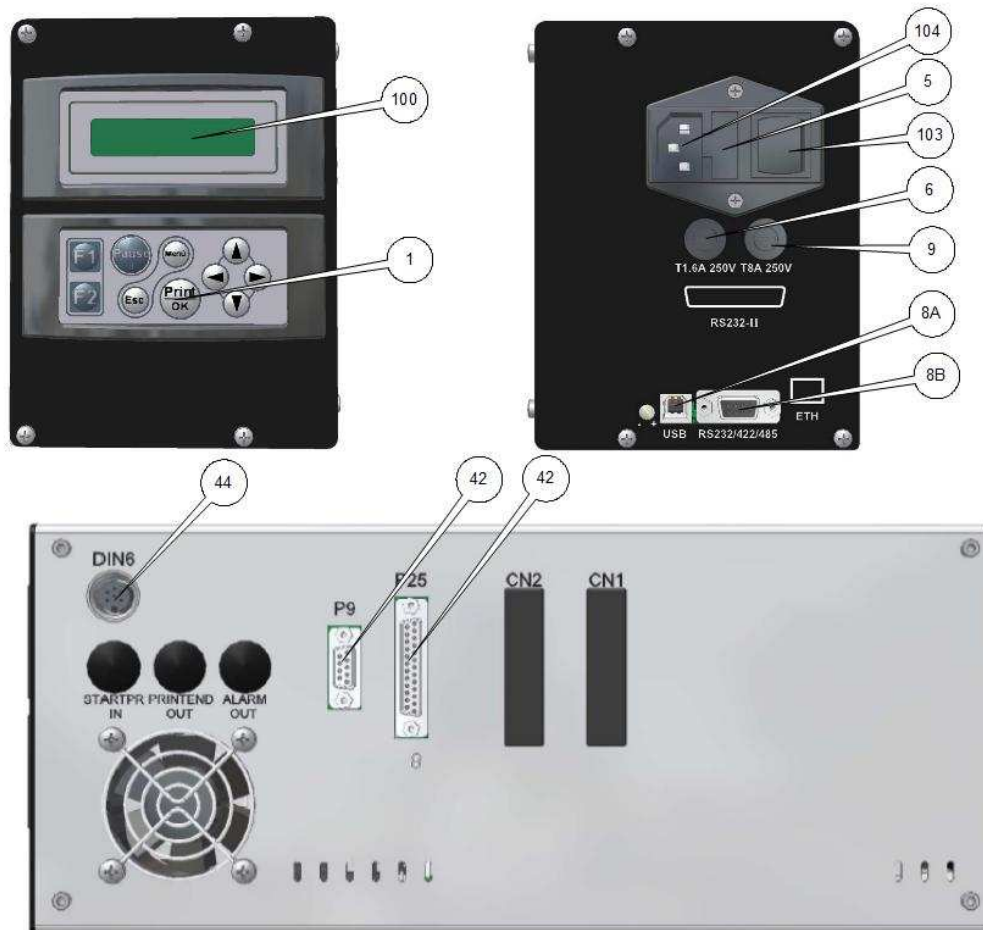

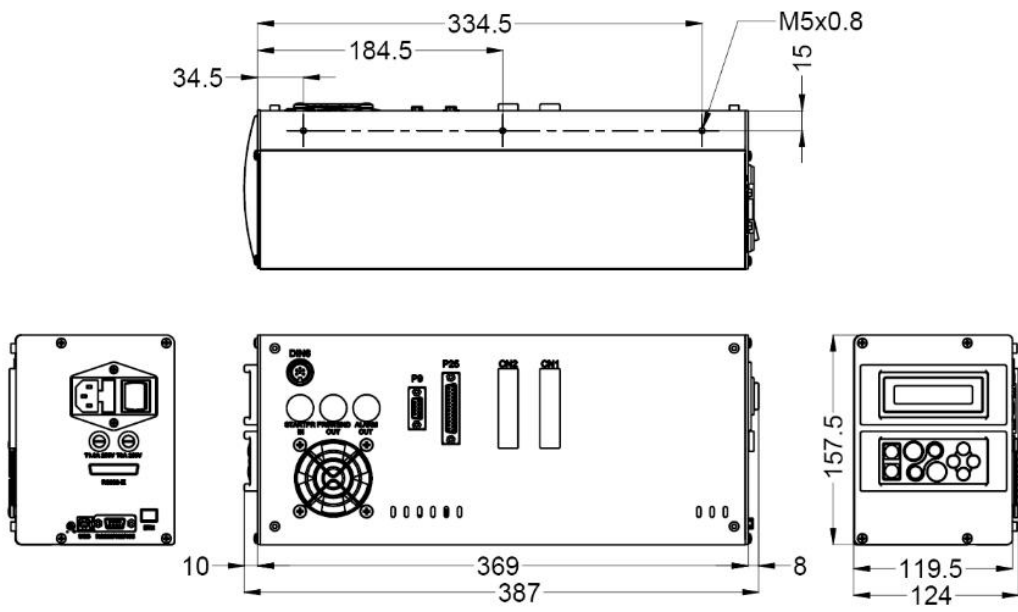

PICTURE 1

Printing mechanism - overall dimensions and fitting holes

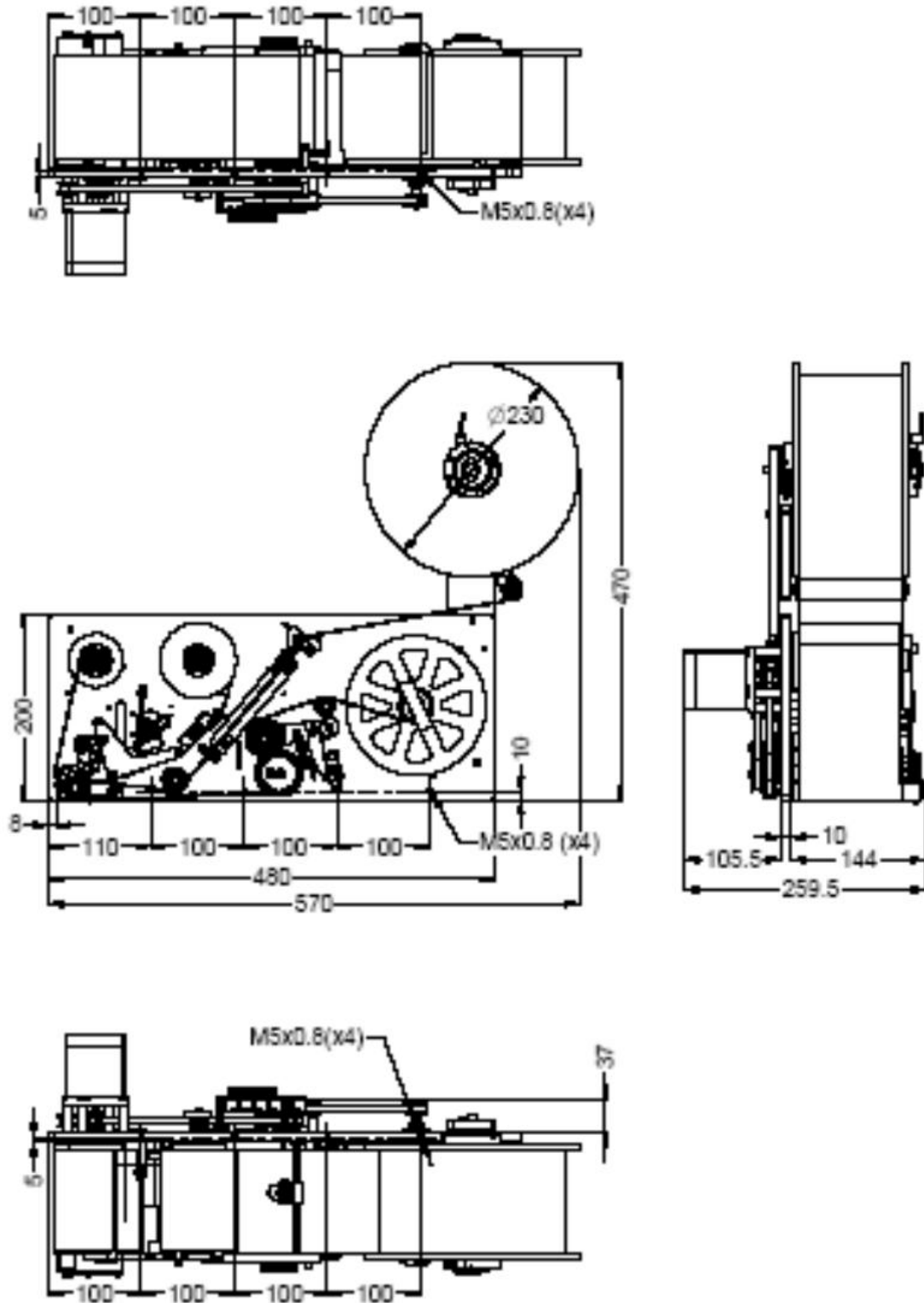

PICTURE 2

4. ROLLS COMPARTMENT DESCRIPTION

(SEE FOLLOWING PICTURES)

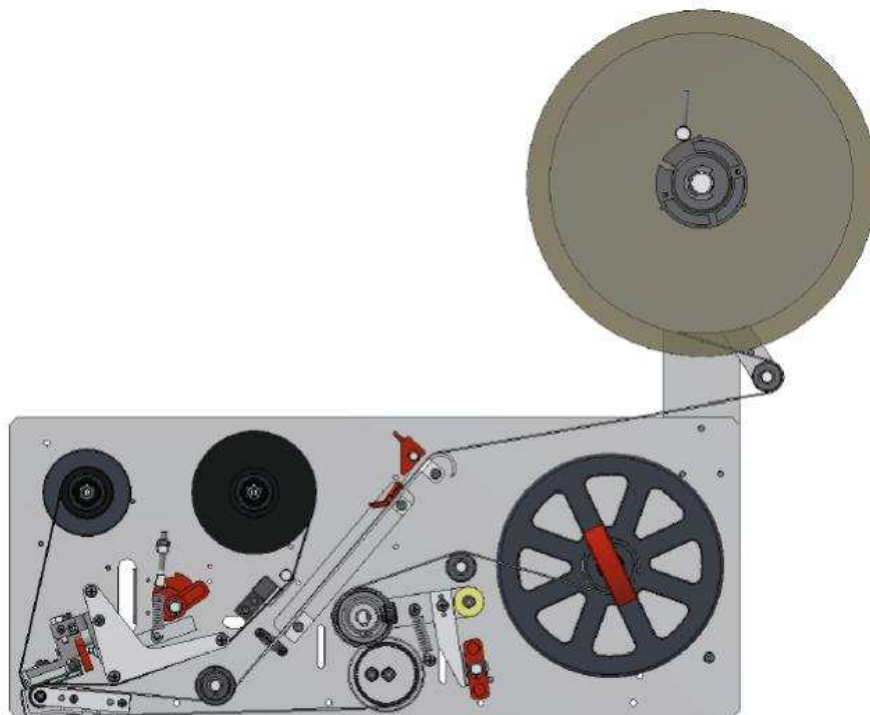
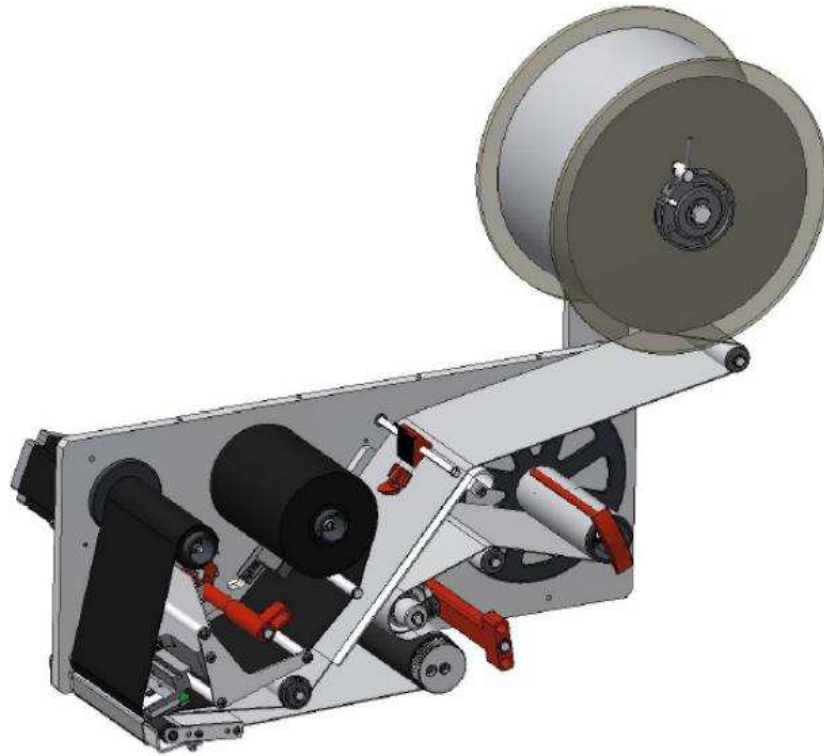

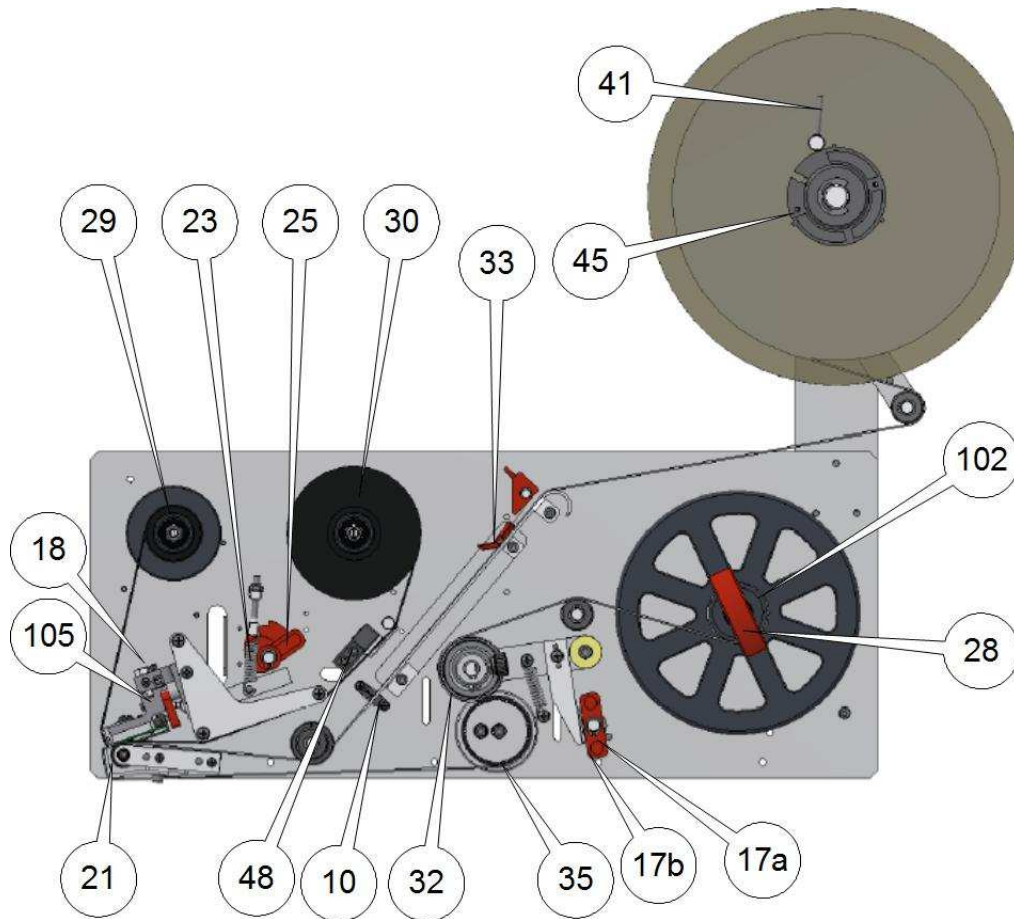

PICTURE 5

- | | |
|---|--|
| 10 - photosensor for end of roll and label synchronisation | 28 - clip holder |
| 17 - lock / unlock toggle lever
17a - working position
17b - open position | 29 - thermal ribbon rewinder |
| 18 - print head position fine adjustment | 30 - thermal ribbon stock |
| 21 - printing roller | 32 - pressure roller |
| 23 - print head assembly pressure spring | 33 - pressure clip |
| 25 - lock / unlock print head lever
25a - working position
25b - open position
25c - cleaning position | 35 - driving roller |
| 29 - thermal ribbon rewinder | 41 - lock / unlock flange lever |
| 30 - thermal ribbon stock | 45 - label unwind holder |
| 32 - pressure roller | 48 - photosensor for end of thermal ribbon |
| 33 - pressure clip | 102 - rewinding shaft |
| 35 - driving roller | 105 - print head assembly |
| 41 - lock / unlock flange lever | 112 - print head connector |
| 45 - label unwind holder | |
| 48 - photosensor for end of thermal ribbon | |
| 102 - rewinding shaft | |
| 105 - print head assembly | |
| 112 - print head connector | |

5. INCOMING INSPECTION

- * Assemble the label unwind holder support and flanges as shown in picture 6, using provided screws and spacers.
- * Proceed with label and ribbon loading, see chapter 7.
- * Connect the Printer Mechanism to the Electronic Control Unit using the two provided cables.
- * Check the correct pinout of the serial Cannon 9 pins female connector and connect the printer to the computer .
- * For further details see chapter 8 "Interfacing".
- * Check the voltage on the name plate next to the power receptacle.
- * Connect the power cable to a grounded power line
- * Switch the main switch on (rear panel)
LIGHT BLUE display ON means operating conditions.
- * Push the PRINT BUTTON, you will get a printing test with the FIRMWARE release information.
- * Sending data from the computer you will get the first printing.
- * Push the PRINT BUTTON to get the last printing again; the printer keeps the information of the last printing until next data arrive.

**NOTE: Printer retains the label length and the baking paper transparency in permanent memory.
In case of change of print media see the following paragraph.**

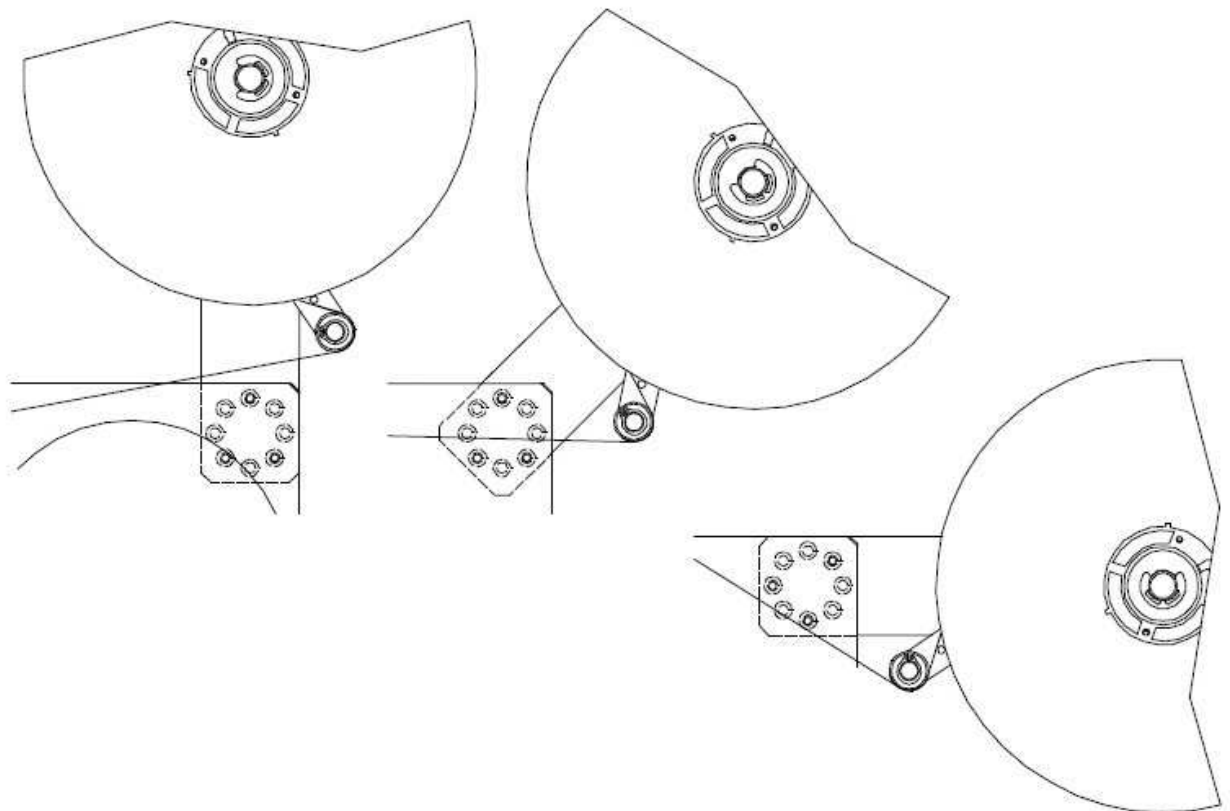
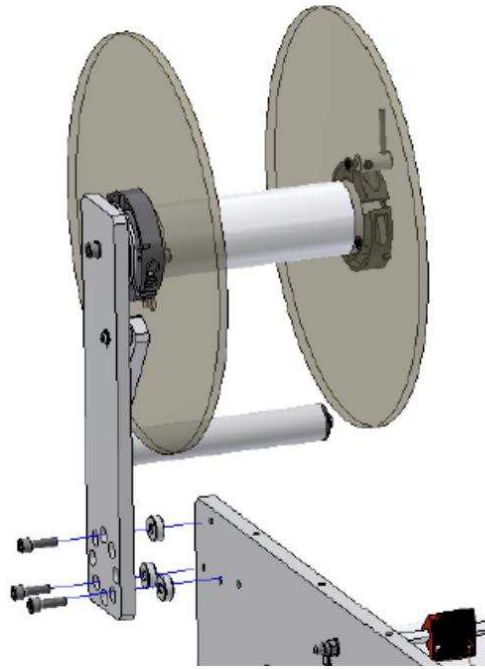

PICTURE 6

5.1. LABEL FORMAT SET UP PROCEDURE

(SEE PICTURE 5)

The printer retains the label length and the backing paper transparency in permanent memory.

If changing label format or print media type you have to use the following procedure to update the values:

- 1 - Switch the printer off.
- 2 - Lift the printing head up by rotating lever #25b.
- 3 - Thread the web between the printing roller and the printing head #21,105.
- 4 - Lift the pressure roller up by rotating lever #17b.

- 5 - Thread the web between the driving roller and the pressure roller #35,32 up to the rewinding shaft #102.
- 6 - Check web has been rightly positioned under the label photosensor #10.
- 7 - Lift the printing head and the pressure roller down by rotating levers #25a and #17a.

- 8 - Switch the printer on while pushing the print button.
- 9 - Printer ejects some labels (depending on their length) and stores the values of the media.
- 10 - Release the print button.
- 11 - The display lits light blue and the printer is ready to work.

6. PRINTING MEDIA DESCRIPTION

6.1. PAPER SPECIFICATIONS

White coated glossy printing paper

- weight: 65 ÷ 90 g/mq (ISO536)
- caliper: 0,075 ÷ 0,083 mm (ISO534)

ADHESIVE SPECIFICATIONS

- peel adhesion(90° C): 430 N/m
- service temperature: -20° C ÷ + 70° C

LINER SPECIFICATIONS

- BG 40 brown, supercalendered glassine
- weight: 65g/mq (ISO536)
- caliper: 0.057 mm (ISO534)
- transparency: 45%

SUGGESTED MODELS

- Fasson Fasthermal NT
- Kanzaki KPT 86-H
- Fasson Fastransfer MP - S470 (TT models)
- Fasson Fastransfer Extra - S470 (TT models)

LABEL DIMENSIONS

See Chapter 2

6.2. THERMAL RIBBON SPECIFICATIONS

- film thickness 4.5 ÷ 6 micron
- core diameter: 25.4 mm
- width: 35 mm min/ 110 mm max
- length: about 600 meters
- ink coating outside

SUGGESTED MODELS

- TOIKO C 250 (matt paper)
- TOIKO CR 150 (glossy paper and polypropylene)
- TOIKO R 300 (plastic media)

STORAGE

Keep labels and ribbons in a dry place at temperature not over 40° C and not exposed to direct sun light.

7. THERMAL RIBBON AND LABEL ROLL REPLACEMENT

7.1. THERMAL RIBBON REPLACEMENT

(SEE PICTURE 7)

Remove the used roll. Remove the core #47 from the shaft #30 and put it on the rewinder #29. By rotating the lever #25b, lift the printing head #105 from the printing roller #21, setting the movement of the ribbon free.

Slide new ribbon #43 onto shaft and thread it under the ribbon photosensor #48 and the threaders #107, 108 and 37 and up round to the rewinder #29. Attach the ribbon leader with label/tape to core #47. Return head lever to closed position #25a (or #25c).

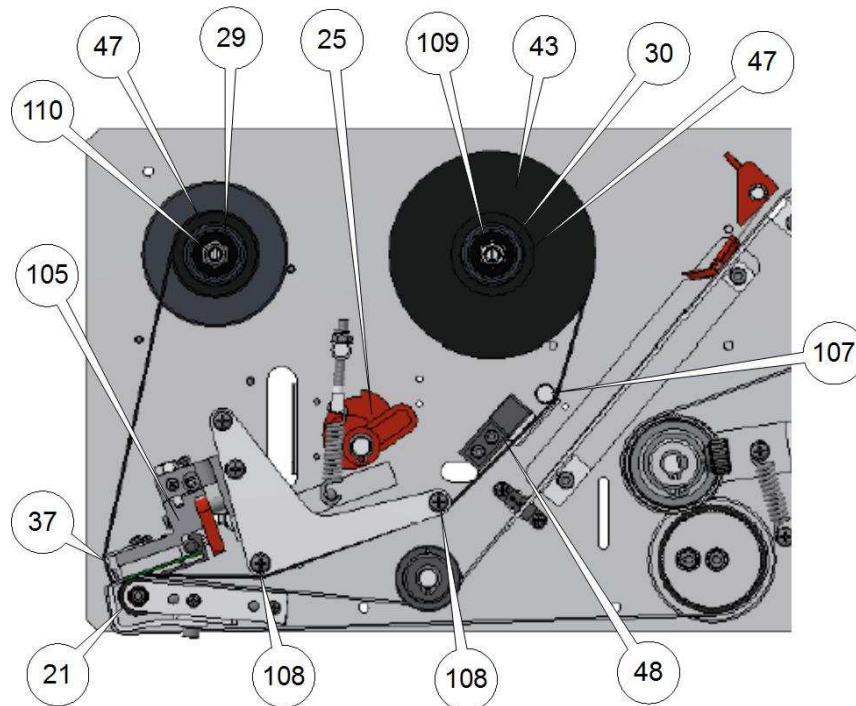

PICTURE 7

7.2. LABEL ROLL REPLACEMENT

(SEE PICTURE 5)

In case of changing of label format or printing media type, remember to follow the "Label format set up procedure" shown on paragraph 5.1.

Remove the movable flange by rotating the lever #41.

Remove the empty label roll.

Insert new label roll onto roller #45

Reassemble the movable flange and push it tightly against the side of the label roll; lock lever #41.

By rotating the lever #17b, lift the pressure roller #32 from the driving roller #35.

Remove clip #28 from the rewinding shaft #102.

Remove backing paper from the rewinding shaft.

Remove the first 50 centimetres from liner of the new roll labels.

Hold pressure clip #33 up and feed the liner through the path, thread the web between the printing roller

and the thermal head #21,105, then around the driving roller and under the pressure roller #35,32, finally slide the liner on the rewinder unit #102 and fasten it with the clip holder #28.

Turn the rewinder to stretch the paper.

Turn head lever and toggle lever back to closed positions #25a,17a.

Check paper has been rightly positioned under the movable label photosensor #10.

Check pressure clip #33 has been positioned between centre and outer side of the label.

WARNING: Italora OEM printer mechanisms must operate only in peel-off mode with backing paper rewound by toggle lever rollers. Any other print mode (strip form, tear-off, etc.) is not allowable and cause an incorrect paper feeding and bad printout quality.

8. PARAMETERS SETTING, DISPLAY AND KEYBOARD

8.1. KEYBOARD

The Printer behaviour in response to the keyboard use depends on the current status of the Printer itself.

POWER-ON

Features available at Printer Switching-ON.

NB: hold down corresponding key while switching on the Printer.

(release the key only after the activation of the desired function)



Press and hold the key on the front panel of the Printer

Switch on the Printer (and release the key previously pressed)

- "Power-ON" keypress procedure -

- Print/OK
 - Run the Printer "Initializing Procedure"
- Menu
 - Access the Printer "Setup Menu" before it reaches the Standard operating mode
- UP Arrow
 - Run the "DUMP Mode" of receiving data

Standard Operating Mode (Ready / Data Receiving)

Features available when the Printer is in Standard operating mode ("Ready").

(Printer Name)
Ready!

- "Ready" Display message -

- Print/OK
 - Print of the content of the Print Buffer (repeat the last label printed)
If the Print Buffer is empty (condition that occurs at Printer Switching-ON or after performing a "Reset Procedure"), the Printer will print the "Test Label", that lists the main Printer's current operating settings
- UP Arrow
 - Increase the energy percentage supplied to the Print-Head (0 - 150 %), accordingly increasing the Print Contrast
- DOWN Arrow
 - Decrease the energy percentage supplied to the Print-Head (150 - 0 %), accordingly decreasing the Print Contrast

WARNING:

a too high percentage may seriously damage the Print-Head or however reduce its life!!

- Menu
 - Access the Printer "Setup Menu"
(refer to "Setup Menu" paragraph)
- F1
 - Access the "Label Layout Selection" section
(refer to "Label Layout Selection (A - Z)" paragraph)
- Pause
 - Enable/Disable the execution of the "Apply Equipment Cycle" stored in Printer memory
(available only on models with Apply Equipment / "OEM Expansion Board")
- "UP Arrow + DOWN Arrow" (simultaneous pressure)

- Run the Printer "Reset Procedure"

Setup Menu

Features available in the Printer "Setup Menu".

- RIGHT/LEFT Arrows
 - Scroll Menu and Submenus Items
- UP/DOWN Arrows
 - Scroll available Options for each Item in Menu and Submenus
 - Increase/Decrease numeric fields in the Options
- Print/OK
 - Store the displayed Option
 - Access Submenus (when the message "OK to Enter" is shown)
 - Run the displayed procedure (when the message "OK to START!" is shown)
- Esc
 - Exit Submenus and return to the previous Menu/Submenu
 - Exit Menu and return to the "Ready" operating condition

WARNING: to really change the value of any option, the "Print/OK" key should be pressed!! Transferring to another Item ("RIGHT/LEFT Arrows") or exiting the Submenu/Menu ("ESC" key) without pressing the "Print/OK" key will NOT STORE the setting of the option previously displayed!! In this case, the settings of the last properly performed storing operation will be kept as valid. Each press of the "Print/OK" key stores the value of the currently displayed option.

Label Layout Selection (A - Z)

Features available in the "Label Layout Selection" section.

- RIGHT/LEFT Arrows
 - Scroll "Label Layouts" ('A' to 'Z')
- UP/DOWN Arrows
 - Scroll available Options ("Set as Default" or "Erase!")
- Print/OK
 - Perform the Option displayed
- Esc
 - Exit the section and return to the "Ready" operating condition

Special Combos

The special combos are keys combinations (starting from "Ready" operating condition) that should be used to access some special features.

Debug Menu

This combo give access to the "Debug Menu", feature that allows to analyze the internal settings of the Printer and (eventually) the external interfacing signals.

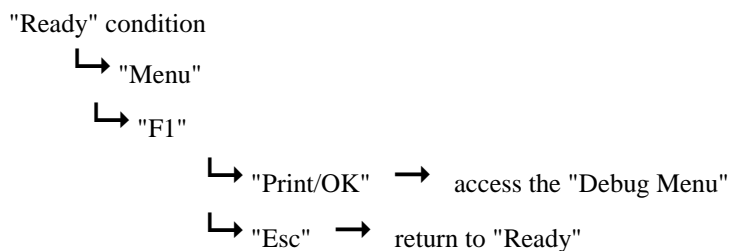

Available features inside the "Debug Menu" of the Printer:

- RIGHT/LEFT Arrows
 - Scroll Menu and Submenus Items
- UP/DOWN Arrows
 - Scroll available Options for "Output Commands" ("ON" or "OFF") (feature available on "OEM" models only)
- Pause
 - Suspend/Resume reading "Internal Sensors"
 - Suspend/Resume reading "Input Signals" (feature available on "OEM" models only)
- Print/OK
 - Access Submenus (when the message "OK to Enter" is shown)

- Run the displayed procedure (when the messages "OK to START!" or "OK to PRINT!" are shown)
- Resume reading "Internal Sensors" from Pause condition
- Resume reading "Input Signals" from Pause condition
(feature available on "OEM" models only)
- Perform the selected Option for "Output Commands"
(feature available on "OEM" models only)
- Esc
 - Exit Submenus and return to the previous Menu/Submenu
 - Exit the Menu and return to the "Ready" operating condition

Batch Print Mode

Features available with Printer in "Batch Print" operating mode.

Batch Copies:
(x) of (N)

- "Batch Print" Display message -

- Pause
 - Suspend/Resume the current Print Cycle
- Print/OK
 - Resume the current Print Cycle from Pause condition
- Esc
 - Quit the current Print Cycle and return to "Stand By" operating condition

Setup Menu

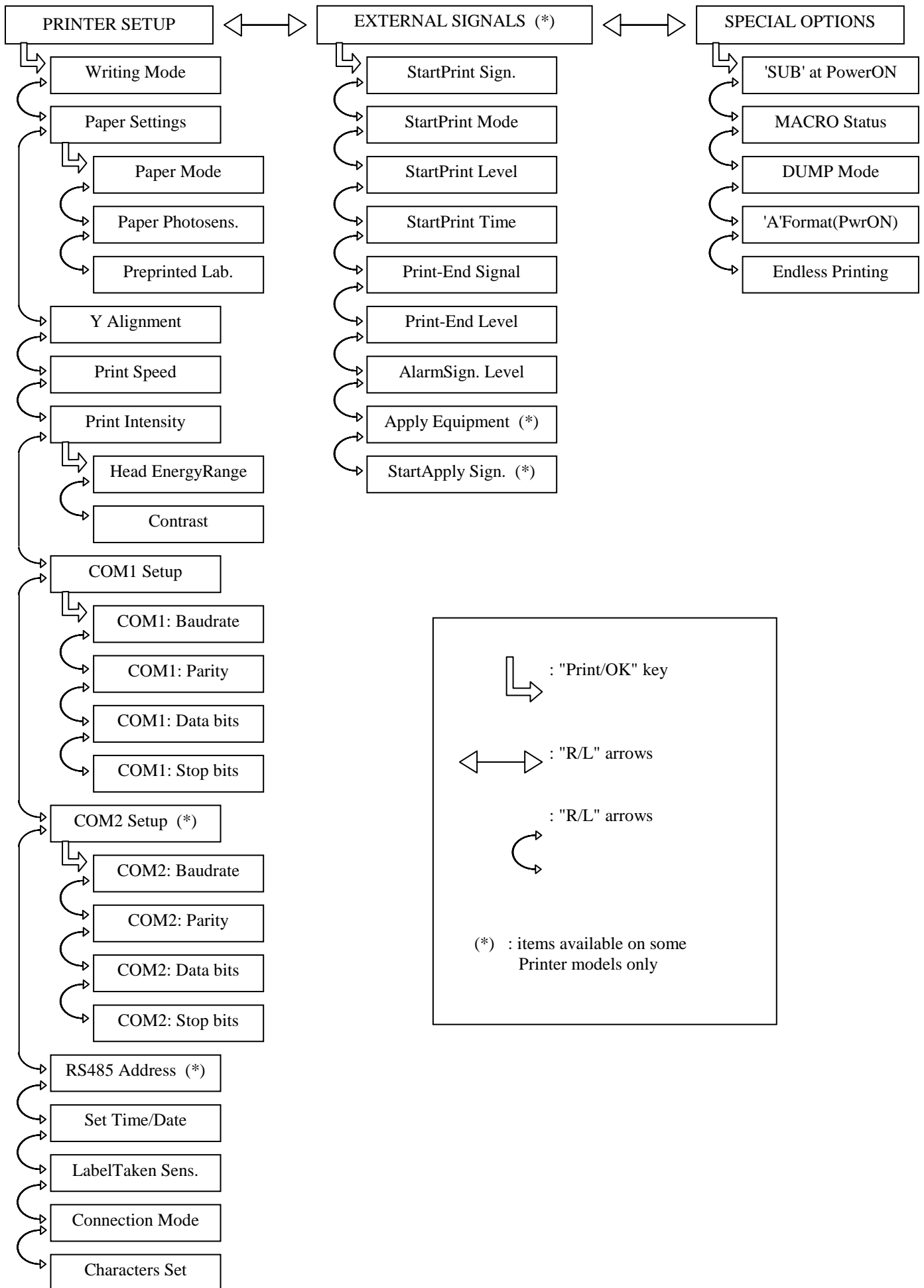

The "Setup Menu" allows to manage Printer operating general settings and parameters.

Available settings are divided into the following Submenus:

- **PRINTER SETUP**
Printer operating parameters
- **EXTERNAL SIGNALS**(available on "OEM" models only)
External Signals management
- **SPECIAL OPTIONS**
special Printer operating modes

PRINTER SETUP

"Printer Setup" Submenu contains the following Items:

- Writing Mode
Printing method:
 - Direct Thermal: directly on thermo-sensitive media
 - Thermal Transfer: through inked ribbon transfer
- Paper Settings
Print Media management:
 - Paper Mode
Print Media typology:
 - Labels: stickers/adhesive labels
 - Continuous: continuous media without marking signs
 - Tag/Tickets: media with marking signs or holes
 - Paper Photosens.
Print Media photosensor typology:
 - Fork
 - Reflection
 - Preprinted Lab.
setting to use pre-printed labels
- Y Alignment
Set the alignment "Gap" at printing end
- Print Speed
Set the Printer printing speed
- Print Intensity
Print Intensity adjusting:
 - Head EnergyRange
limitation of the energy supplied to the Print-Head:
 - Standard (Low): limitation enabled, operating in "Low Energy" range
 - High Energy: limitation disabled, operating in "High Energy" range
 - Contrast
percentage of energy supplied to the Print-Head (Print Contrast)
- COM1 Setup
Serial communication settings for "COM1" Port
 - COM1: BAUDRATE
 - COM1: PARITY
 - COM1: DATA bits
 - COM1: STOP bits
- COM2 Setup (available on "two-RS232 COM Port" models only)
Serial communication settings for "COM2" Port
 - COM2: BAUDRATE
 - COM2: PARITY
 - COM2: DATA bits
 - COM2: STOP bits
- RS485 Address (available on "RS485" models only)
Printer address for communication on "RS485" protocol
- Set Time/Date
Internal Time/Date settings
- LabelTaken Sens.
Use/Presence of Label-Taken Sensor
- Connection Mode
Control Characters receiving mode
 - Standard: received characters are not modified
 - Mainframe: conversion of all Control Characters received in the "Carriage Return"

character (CR, ASCII code = 13)

- Characters Set
Alphabetical Characters Set selection

EXTERNAL SIGNALS (AVAILABLE ON "OEM" MODELS ONLY)

"External Signals" Submenu contains the following Items:

- StartPrint Sign.
Enable/Disable Start-Print Signal
- StartPrint Mode
Start-Print Signal operating mode selection
- StartPrint Level
Set the Start-Print Signal logic level of activation
- StartPrint Time
Set the Start-Print Signal minimum period
- Print-End Signal
Print-End Signal operating mode selection
- Print-End Level
Set the Print-End Signal logic level of activation
- AlarmSign. Level
Set the Alarm Signal / Auxiliary Out logic level of activation
- Apply Equipment (available on "OEM" and "OEM Expansion Board" models only)
Enable/Disable the execution of the "Apply Equipment Cycle"
- StartApply Sign. (available on "OEM" and "OEM Expansion Board" models only)
Enable/Disable Start-Apply Signal

SPECIAL OPTIONS

"Special Options" Submenu contains the following Items:

- 'SUB' at PowerON
Send of "SUB" character (by the Printer) every time the power is restored (eg: at Power-ON or in case of voltage drops)
- MACRO Status
"Macro Interpreter" operating mode:
the Printer automatically composes the labels with data directly received from the device to which it is connected (eg: an electronic balance)
- DUMP Mode
"DUMP" operating mode:
the Printer decodes all the received characters and prints them as a sequence of single values depending on the set code (hexadecimal, decimal or ASCII)
- 'A'Format(PwrON)
Management of the "Label 'A' Format" auto-activation at Power-ON
- Endless Printing
Endless Printing operating mode:
continuous printing of data contained in the Print Buffer

Debug Menu

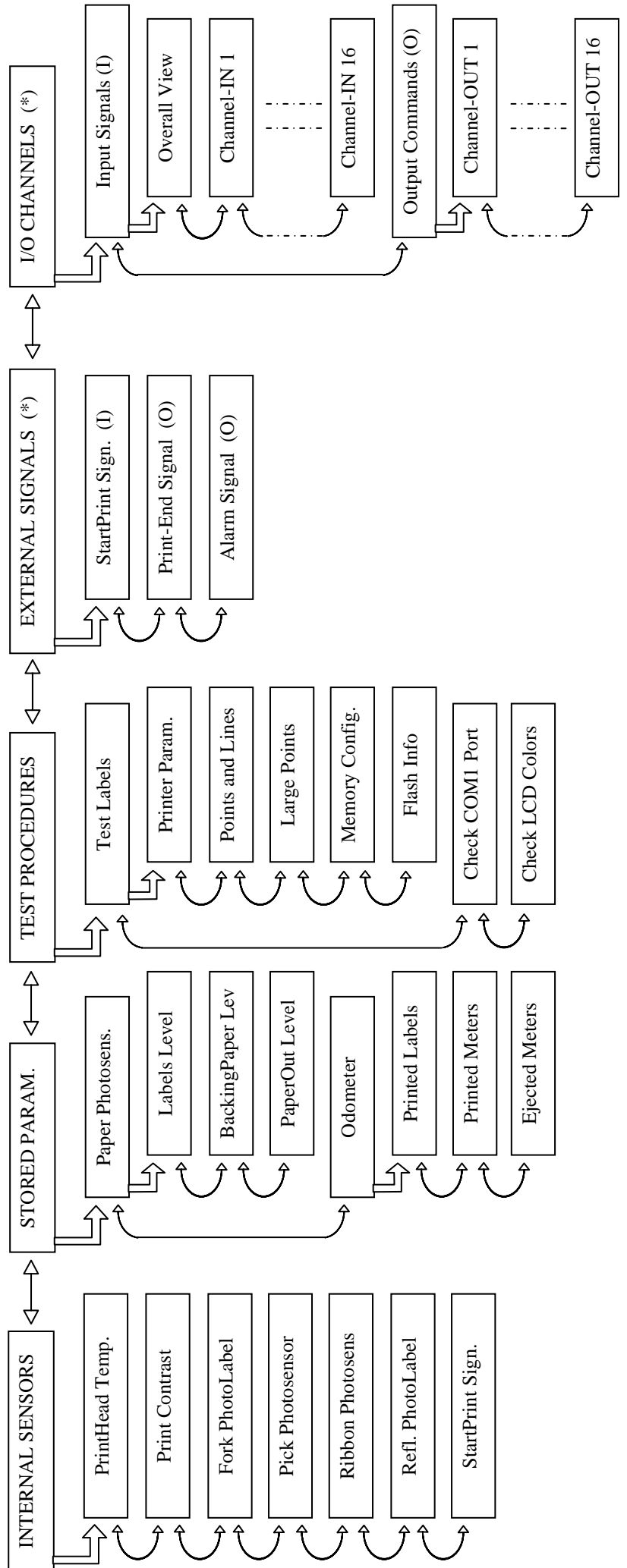
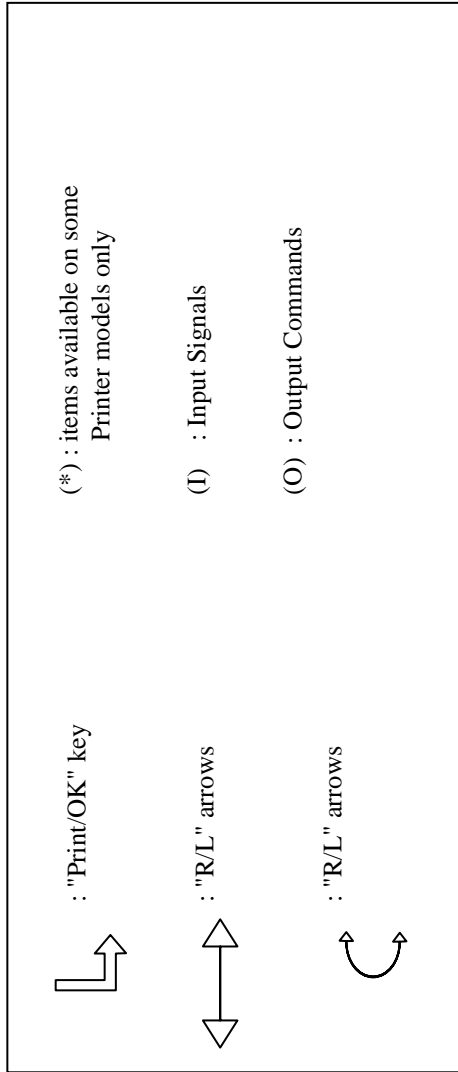

The "Debug Menu" allows to monitor and analyze Printer settings and (eventually) the external interfacing signals, in order to identify and solve any faults or malfunctioning.

Available settings are divided into the following Submenus:

- **INTERNAL SENSORS**
Printer Internal Sensors interrogation
- **STORED PARAM.**
displaying of parameters related to Print Media transparencies and made/performed Prints
- **TEST PROCEDURES**
procedures to test some Printer features
- **EXTERNAL SIGNALS** (available on "OEM" models only)
External Control Signal analysis
- **I/O CHANNELS** (available on "OEM" and "OEM Expansion Board" models only)
Input Signals and Output Commands analysis

INTERNAL SENSORS

- PrintHead Temp.: Print-Head temperature
- Print Contrast: Print Contrast percentage
- Fork PhotoLabel: value read from Print Media Photosensor (Fork type)
- Pick Photosensor: value read from Label-Taken Photosensor
- Ribbon Photosens: value read from Inked Ribbon Photosensor
- Refl. Photolabel: value read from Print Media Photosensor (Reflection type)
- StartPrint Sign.: Start-Print Signal value

STORED PARAM.

- o Paper Photosens.
Print Media transparencies, stored during the last alignment procedure:
 - Labels Level: boundary value of labels detection
 - BackingPaper Lev: boundary value of backing-paper detection
 - PaperOut Level: boundary value of End-Media detection
- o Odometer
parameters related to made/performed Prints:
 - Printed Labels: number of printed labels
 - Printed Meters: amount of printed Print Media
 - Ejected Meters: amount of ejected Print Media

TEST PROCEDURES

- o Test Labels
print of Test/Check Labels:
 - Printer Param.: Printer operating settings (also called "Printer Test Label")
 - Points and Lines: Print-Head dots integrity check pattern
 - Large Points: Print-Head dots integrity check pattern
 - Memory Config.: Printer's memories settings
 - Flash Info: Printer's Flash Memory settings
- o Check COM Port
serial communication check procedure (available for "COM1" Port only)
- o Check LCD Colors
8-color LCD Display check procedure

EXTERNAL SIGNALS

(AVAILABLE ON "OEM" MODELS ONLY)

- StartPrint Sign.: Start-Print Signal status
- Print-End Signal: Print-End Signal management
- Alarm Signal: Alarm Signal / Auxiliary Out management

I/O CHANNELS

(AVAILABLE ON "OEM" AND "OEM EXPANSION BOARD")

- o Input Signals
reading of the 16 Input Signals ("Channel-IN")
- o Output Commands
management of the 16 Output Commands ("Channel-OUT")

8.2. MEANING OF DISPLAY COLOURS

The Printer display can use different background colours. The meaning of these colours is the following:

- Light Blue:
 - "Ready" operating condition
- Red:
 - Error/Alarm condition due to factors external to the Printer (need for direct Operator intervention to identify and solve the problem)
- Yellow:
 - Error/Alarm condition due to critical operating conditions internal to the Printer (Printer resumes when operating conditions go back to the optimal ones)
- Blue:
 - browsing the Printer "Setup Menu"
 - browsing the "Label Layout Selection" section
 - browsing the "RAM Memory Backup" section
- Violet:
 - browsing the Printer "Debug Menu"
- Dark Blue:
 - Printer busy/engaged in internal procedures
 - Pause status during "Batch Print Mode"
 - Pause status while reading "Internal Sensors" (Debug mode)
 - Pause status while reading "Input Signals" (Debug mode) (available on "OEM" models only)
- Green:
 - "Ready" operating condition when the execution of the "Apply Equipment Cycle" is enabled. (available on "OEM" and "OEM Expansion Board" models only)
- Yellow/Green blinking:
 - need for Operator intervention to restart Printer (when the message "Turn OFF/ON to do" is shown)

9. INTERFACING

9.1. SERIAL INTERFACE

Electronic Control Units for **AH 870 EL7**, **AH 871 GM EL7** and **AH 1271 GM EL7** printer mechanisms have a RS232/422/485 hardware interface. Provided on board connector is a Cannon 9 pins "DB" female cabled as shown in the following pictures.

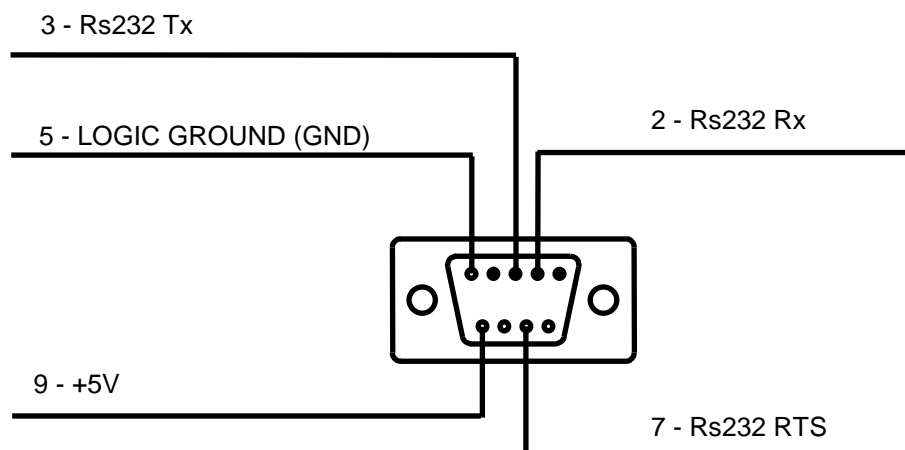

Connection to personal computer may be done in different ways:

COMPUTER CONNECTOR - 9 PIN		COMPUTER CONNECTOR - 25 PIN	
COMPUTER	PRINTER	COMPUTER	PRINTER
2	3 TX	3	3 TX
3	2 RX	2	2 RX
8	7 RTS	5	7 RTS
5	5 GND	7	5 GND

COMPUTER CONNECTOR: -using sw protocol XON/XOFF: short together PINS 7-8 and 1-4-6.		COMPUTER CONNECTOR: -using sw protocol XON/XOFF: short together PINS 4-5 and 6-8-20.	
-using hw protocol CTS/RTS: short together PINS 1-4-6.		-using hw protocol CTS/RTS: short together PINS 6-8-20.	

Rs422 – DB9 CONNECTOR

Connector pinout is

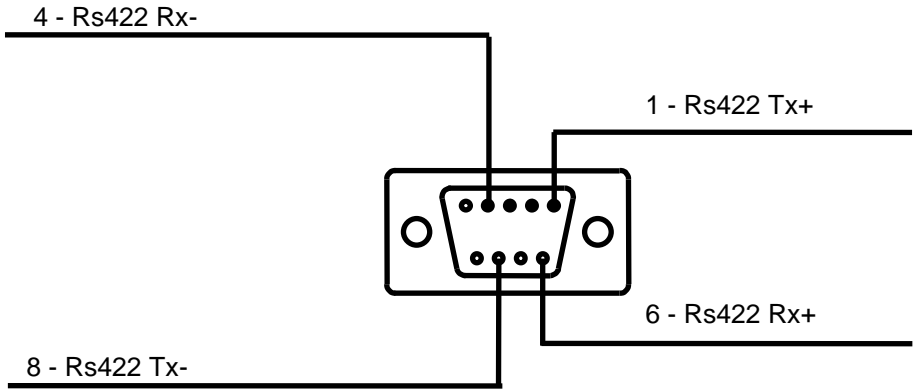

HANDSHAKE PROTOCOL

Rs422 serial line has no handshake protocol.

It means that if you transmit more than 2 / 3 KBytes of data at a time it's strongly recommended to insert a short delay (1 or 2 msec) between transmission of each character, in order to avoid printer errors during data receiving; alternatively software XON / XOFF handshake mode may be used.

Connection to personal computer may be done in different ways based on used converter.

Rs485 – DB9 CONNECTOR

Connector pinout is

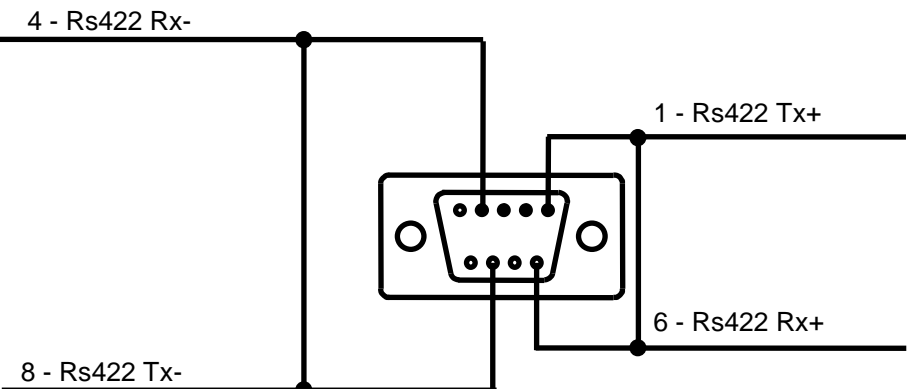

Maybe you'll need to do a short circuit between pins 2 and 4 on printer side connector, in order to enable the line terminator resistance (already included on the cpu board).

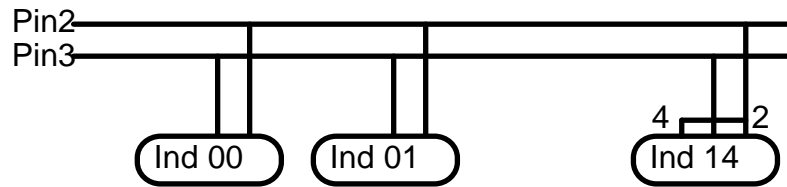

HANDSHAKE PROTOCOL

RS 485 serial line has no handshake protocol.

In fact CTS printer signal, normally used in RS232 serial line to stop data transmission, is used here to set up the direction of data stream.

It means that if you transmit more than 2 / 3 KBytes of data at a time it's strongly recommended to insert a short delay (1 or 2 msec) between transmission of each character, in order to avoid printer errors during data receiving. Connection to personal computer may be done in different ways based on used converter.

9.2. I/O SIGNALS

**Wiring for I/O signals
6 poles DIN connector**

Pick & Place working mode allows an external device (i.e. PLC, photocell, pneumatic applicator, etc...) to start or halt printing.

When Pick & Place options is enabled 3 optoisolated signals are available:

START PRINT	Input – print consent
PRINT END	Output – print end signal
ALARM	Output – auxiliary output for error conditions

These 3 signals are mapped on a 6 poles DIN tap.
DIN plug has following outline:

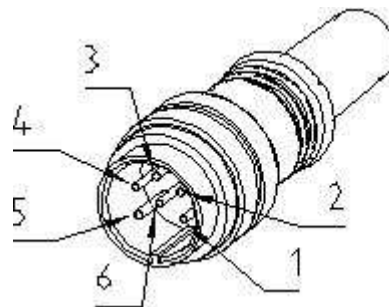

External view

**Wiring for I/O signals
3,4 and 5 poles connectors**

Pick & Place working mode allows an external device (i.e. PLC, photocell, pneumatic applicator, etc...) to start or halt printing.

When Pick & Place options is enabled 3 optoisolated signals are available:

START PRINT	Input – print consent
PRINT END	Output – print end signal
ALARM	Output – auxiliary output for error conditions

Devices with I/O expanded control unit, internale +24V supply and ground have these 3 signals mapped, besides on a 6 poles female connector, also on a 3,4 and 5 poles male connector .
See details ahead in these pages.

Pin out for Electronic Unit without expansion board - External power supply and ground

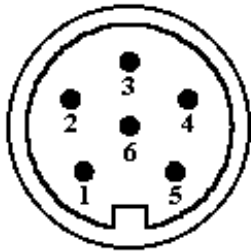

- 1) + START PRINT (INPUT)
- 2) - START PRINT (INPUT)
- 3) + ALARM (OUTPUT)
- 4) - ALARM (OUTPUT)
- 5) + PRINT END (OUTPUT)
- 6) - PRINT END (OUTPUT)

DIN plug
Internal view, soldering side

Pin out for Electronic Unit without expansion board - Internal power supply and ground

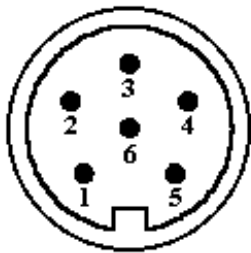

- 1) + START PRINT (INPUT)
- 2) - START PRINT (INPUT)
- 3) +24/20/10,5 V
- 4) GND
- 5) + PRINT END (OUTPUT)
- 6) - PRINT END (OUTPUT)

DIN plug
Internal view, soldering side

Pin out for Electronic Unit with expansion board – Internal +24V power supply and ground

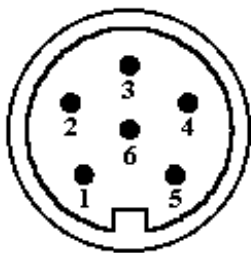

- 1) + START PRINT (INPUT)
- 2) GND
- 3) + ALARM (OUTPUT)
- 4) GND
- 5) + PRINT END (OUTPUT)
- 6) +24V

DIN plug
Internal view, soldering side

Wiring for I/O signals

Electronic Unit without expansion board

External power supply and ground

START PRINT
(soldering side view)

SWITCH

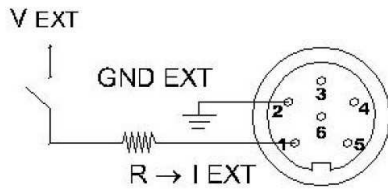

PNP Photocell

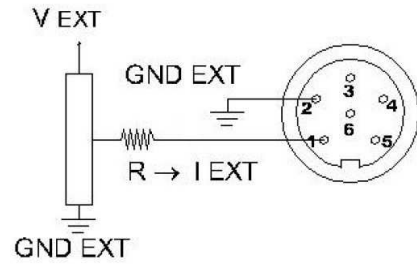

Input signal

Vext = external tension
Iext = current on external circuit
R = external circuit resistance

Vext (Volt)	Iext (mA)	R (Ohm)
24	15	1270
24	30	470
24	50	150
12	15	470
12	30	70
5	15	0

suggested values in **bold**

ALARM and PRINT END signals
(soldering side view)

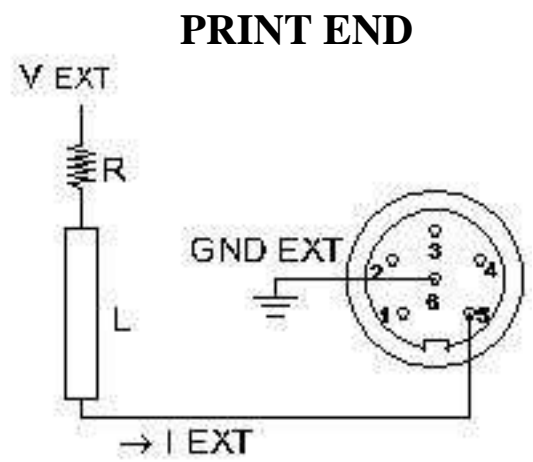
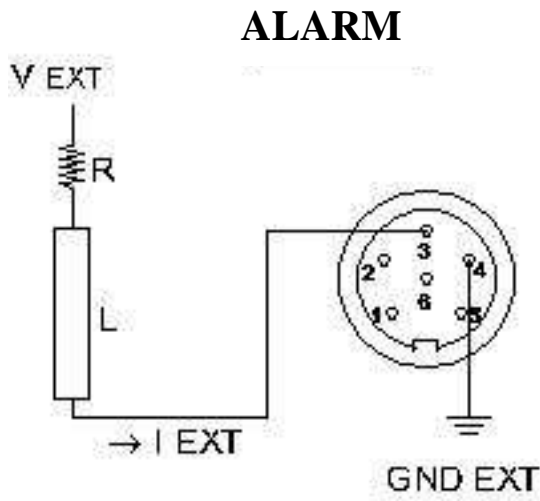

Output signals

Alarm and Print End

Vext = external tension

Iext = current on external circuit

R = Current limiting resistance of external circuit

L = Load impedance of external circuit

Vext (Volt)	Iext (mA)	R + L (Ohm)
24	10	2400
24	20	1200
24	50	240
12	10	1200
12	20	600
12	50	120
5	10	500
5	20	250
5	50	100

suggested values in **bold**

Wiring of I/O signals

Electronic Unit without expansion board

Internal power supply and ground

START PRINT
(soldering side view)

SWITCH

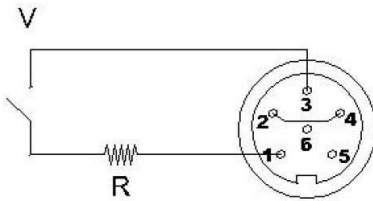

PNP Photocell

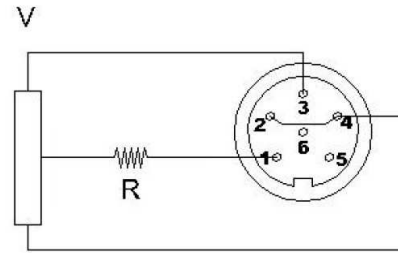

Input signal

V = Internal tension

I = current

R = external circuit resistance

V (Volt)	I (mA)	R (Ohm)
24	15	1270
24	30	470
24	50	150
12	15	470
12	30	70
5	15	0

suggested values in **bold**

PRINT END signal – ALARM signal is unavailable
(soldering side view)

PRINT END

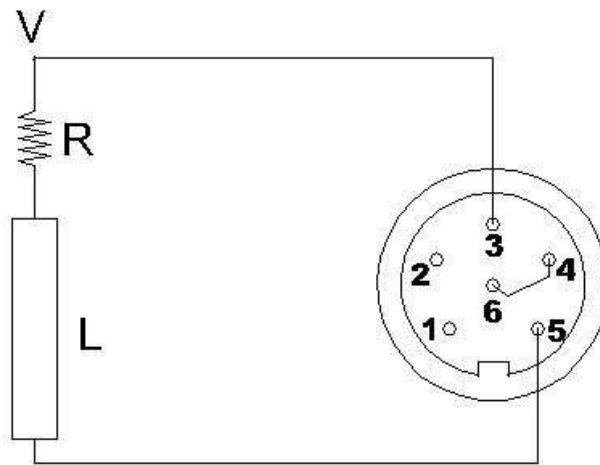

Output signal

Print End

V = external tension

I = current on external circuit

R = Current limiting resistance of external circuit

L = Load impedance of external circuit

V (Volt)	I (mA)	R + L (Ohm)
24	10	2400
24	20	1200
24	50	240
12	10	1200
12	20	600
12	50	120
5	10	500
5	20	250
5	50	100

suggested values in **bold**

Wiring of I/O signals
Electronic Unit with expansion board
+24V internal power supply and ground

START PRINT signal
(soldering side view)

SWITCH

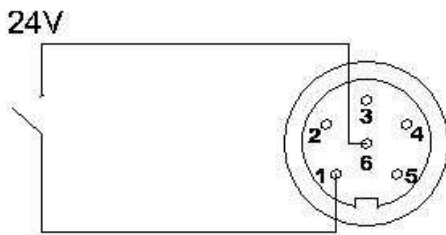

PNP Photocell

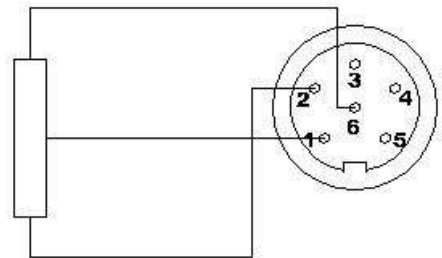

Input signal

Internal circuit resistance = 1800 Ohm

ALARM and PRINT END signals
(soldering side view)

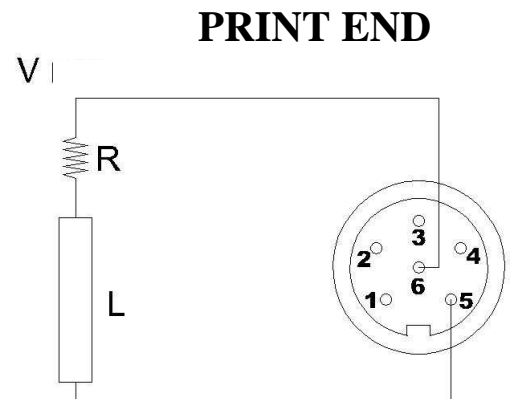
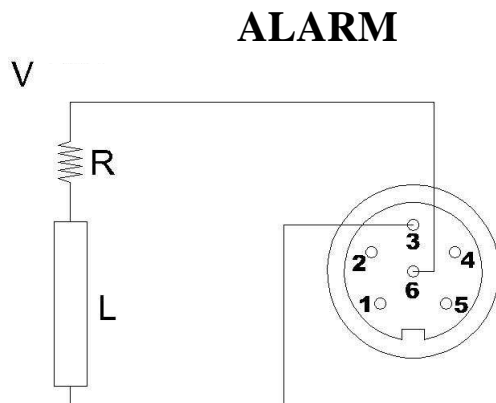

Output signals

Alarm and Print End

V = internal tension

I = current

R = Current limiting resistance of external circuit

L = Load impedance of external circuit

V = internal +24 Volt

Output transistor can drive up to 1 ampère.

$$I = V/(R+L)$$

$$I_{max} = 1A$$

V (Volt)	I (mA)	R + L (Ohm)
24	10	2400
24	20	1200
24	50	240

suggested values in **bold**

Wiring of I/O signals 3, 4 e 5 poles connectors

Devices with I/O expanded control unit, internale +24V supply and ground have these 3 signals mapped, besides on a 6 poles female connector, also on a 3,4 and 5 poles male connector .
Sockets for signal wiring have following configurations:

Pin out for Electronic Unit with expansion board – Internal +24V power supply and ground

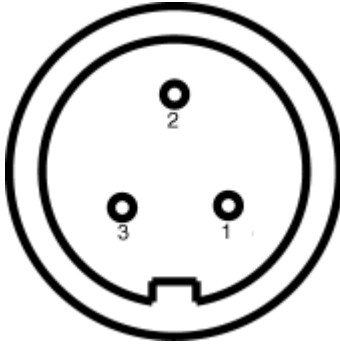

- 1) GND
- 2) +24V
- 3) INPUT - START PRINT signal

3 poles, female, START PRINT signal
Internal view, soldering side

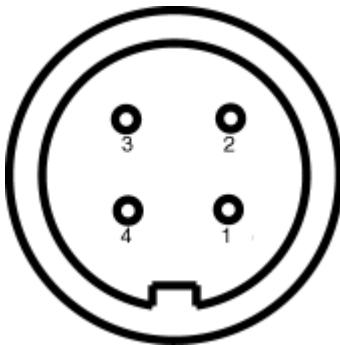

- 1) GND
- 2) +24V
- 3) OUTPUT - PRINT END signal
- 4) unused

4 poles, female, PRINT END signal
Internal view, soldering side

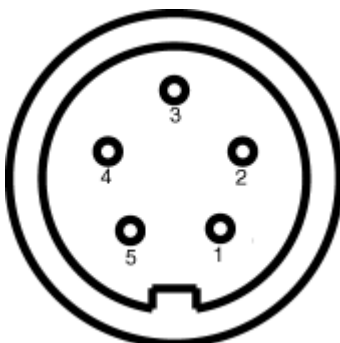

- 1) GND
- 2) +24V
- 3) OUTPUT - ALARM signal
- 4) unused
- 5) unused

5 poles, female, ALARM signal
Internal view, soldering side

START PRINT signal
(soldering side view)

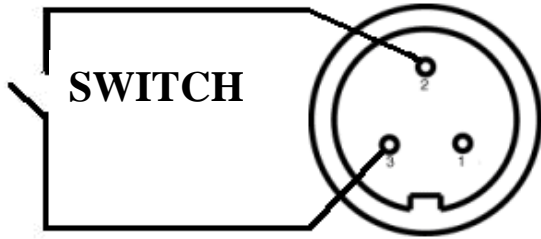

PHOTOCELL

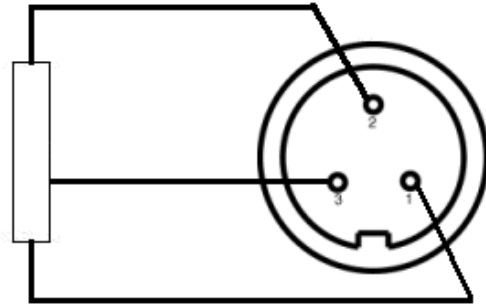

Input signal

Internal circuit resistance = 1800 Ohm

ALARM and PRINT END signals
(soldering side view)

PRINT END

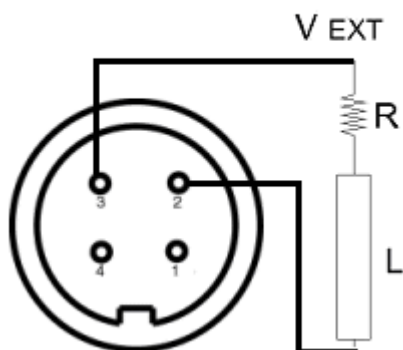

ALARM

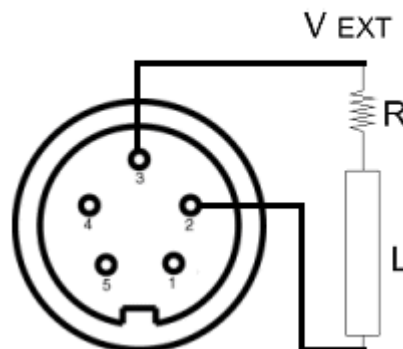

Output signals

Alarm and Print End

V = internal tension

I = current

R = Current limiting resistance of external circuit

L = Load impedance of external circuit

V = internal +24 Volt

Output transistor can drive up to 1 ampère.

$$I = V/(R+L)$$

$$I_{max} = 1A$$

V (Volt)	I (mA)	R + L (Ohm)
24	10	2400
24	20	1200
24	50	240

suggested values in **bold**

10. MAINTENANCE

WHEN NOT IN USE:

- SWITCH OFF POWER
- ALWAYS LIFT UP THE PRINTHEAD AND THE TOGGLE LEVER MECHANISM

10.1. CLEANING

Print Head

- Turn the power off.
- Wait until thermal head cools down.
- Lift the print head by using the lever
- Remove labels and thermal ribbon.
- Moisten a cotton bud with isopropyl alcohol.
- Place it between thermal head and roller and move it gently from side to side.
- Repeat until clean.
- Slowly pull out cotton bud
- Wait until dry before use

WARNING: never use hard tools as this may damage the print head.

Rubber feeding roll: use alcoholic detergents.

Photosensor: use a soft brush.

Metallic and plastic parts: use a soft cloth with water-based detergent (weak).

Removing adhesive traces or parts of labels: use alcoholic detergents. Be careful the liquid does not drip on the electronic compartment.

11. TROUBLE SHOOTING

11.1. NO LABELS FEEDING

Four situations may occur.

a) Display is OFF, check (pict.1,#100):

- main voltage
- main switch (pict.1,#103) ON.
- main connector (pict.1,#104) plugged in
- main fuses (pict.1,#6) intact.

b) Display is RED, check:

- label roll is not used up.

- paper position under the photosensor (pict.5,#10)

c) Display is RED, check:

- thermal ribbon is not used up.
- thermal ribbon position under the photosensor (pict.5,#48).

d) Display is YELLOW:

- head temperature control active, printer stops until temperature has fallen to normal values.

11.2. INCORRECT LABEL ALIGNMENT

Make sure that:

- print head is closed (pict.5,#25a)
- toggle lever is closed (pict.5,#17a)
- paper position under the photosensor (pict.5,#10)
- backing paper is correctly rewound (pict.5,#102)
- pressure clip (pict.5,#33) is positioned

between centre and outer side of the label.

- movable flange is tightly pushed against the side of the label roll with the lever (pic.5,#41) in lock position.

See also "Label format set up procedure" paragraph 5.1

11.3. PAPER SLIDES TO RIGHT SIDE

Check whether:

- pressure clip (pict.5,#33) is positioned between centre and outer side of the label.

- movable flange is closely positioned against the side of the label roll with the lever (pic.5,#41) in lock position.

11.4. PRINTING WITH PATCHES MISSING

Check whether:

- thermal print head needs cleaning (chapter 9)
- thermal ribbon unwinds correctly.

- there are creases on the rewound thermal ribbon. If so, turn the nut (pict.7,#110) clockwise, in order to increase the rewinding torque (a quarter of a turn max) while holding the roller (pict.7,#29) still.

11.5. BLANK LABELS

Check whether

- the fuse (8AT) on the back panel has blown
- the print head connector is correctly plugged in

(pict.4,#112) with polarity key up.

- thermal ribbon is correctly positioned, opaque surface on the label side.

11.6. POOR PRINTING CONTRAST

- Printer Standard operating mode ("**Ready**" **Display message**).

- UP Arrow
Increase the energy percentage supplied to the Print-Head (0 - 150 %), accordingly increasing the Print Contrast
- DOWN Arrow
Decrease the energy percentage supplied to the Print-Head (150 - 0 %), accordingly decreasing the Print Contrast

Otherwise use the software command ?77& (see Programming Manual).

BEWARE: continual high operating temperature of thermal head may reduce its working life and may also fuse the ribbon.

12. HARDWARE NOTES

12.1. HOW TO CHECK ELECTRONIC BOARDS

- **First unplug the power cable from the electronic cabinet.**

- turn the 4 front and the 4 rear screws out (pict.8#114 - 121).

- remove front and rear panels.

- turn the 4 side screws out (pict.8,#122 - 125).

- turn the 3 inner screws out (pict.8,#126 - 128).

- Unplug the following connectors from CPU board (pict.21 and 21 bis).and pull carefully off the electronic boards from the chassis

Y2 = ribbon photosensor

Y3 = LCD

Y4 = stepping motor

Y5 = label photosensor

Y7 = serial port

Y9 = thermal head (**AH 870**)

Y11 = I/O signals

Y14 = fan

Y17 = keyboard

Y18 = LCD

Y29 = USB

Y30 = power supply

Y15 and YGM = thermal head (**AH 871 GM, AH 1271 GM**)

- disconnect the ground cable turning the chassis nut out

- unplug the fuses connectors and the main switch connector.

12.2. PRINT HEAD PROTECTION FUSE REPLACEMENT

- Thermal print head is protected by an 8 A timed fuse (pict.1,#9).

12.3. THERMAL PRINT HEAD REPLACEMENT

(SEE PICTURE 9)

- 1 switch the printer off .
- 2 unplug connector(s) #112 from the print head.
- 3 lift print head by rotating the lever #25c..
- 4 turn the screw #130 out.
- 5 remove the adjusting nut #18.
- 6 pull out the print head and dissipater assembly from the pivot pin.
- 7 turn the screw #138 out and remove the print head #26 from the dissipater.
- 8 replace thermal head and run back steps 7 to 2.

WARNING: pay attention to plug in correctly thermal head connector(s), wrong connection causes

irreversible damage to the print head functionality (pict. 4)

- 9 in case of printing quality problems, loosen the screw #130 and turn slowly the adjusting nut in or out #18, for the best printing quality, finally lock the screw #130.
- 10 in case of creases on the rewound thermal ribbon, loosen the screws #128,129 and adjust the plate #37 in order to obtain a correct parallelism and flatness on the rewound ribbon; finally lock the screws #128,129 (TT models).

12.4. DRIVE BELT REPLACEMENT

(SEE PICTURE 10)

Loosen the relevant idler #16 and remove the belt.
Replace the relevant belt and stretch it by the idler till

you get a deflection of 4 to 6 mm when applying a force of 7 N.

13. PICTURES



PICTURE 8

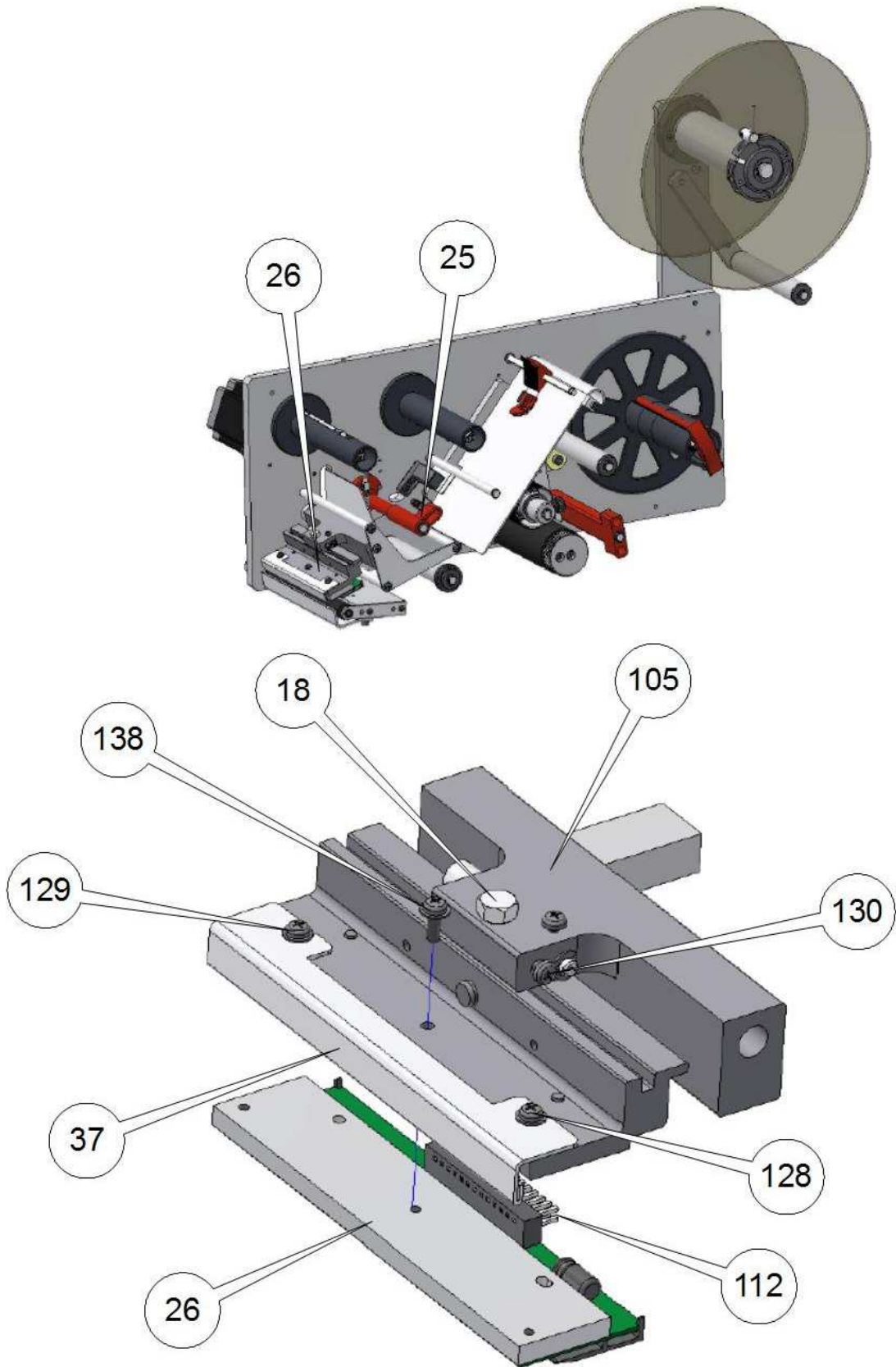

PICTURE 9

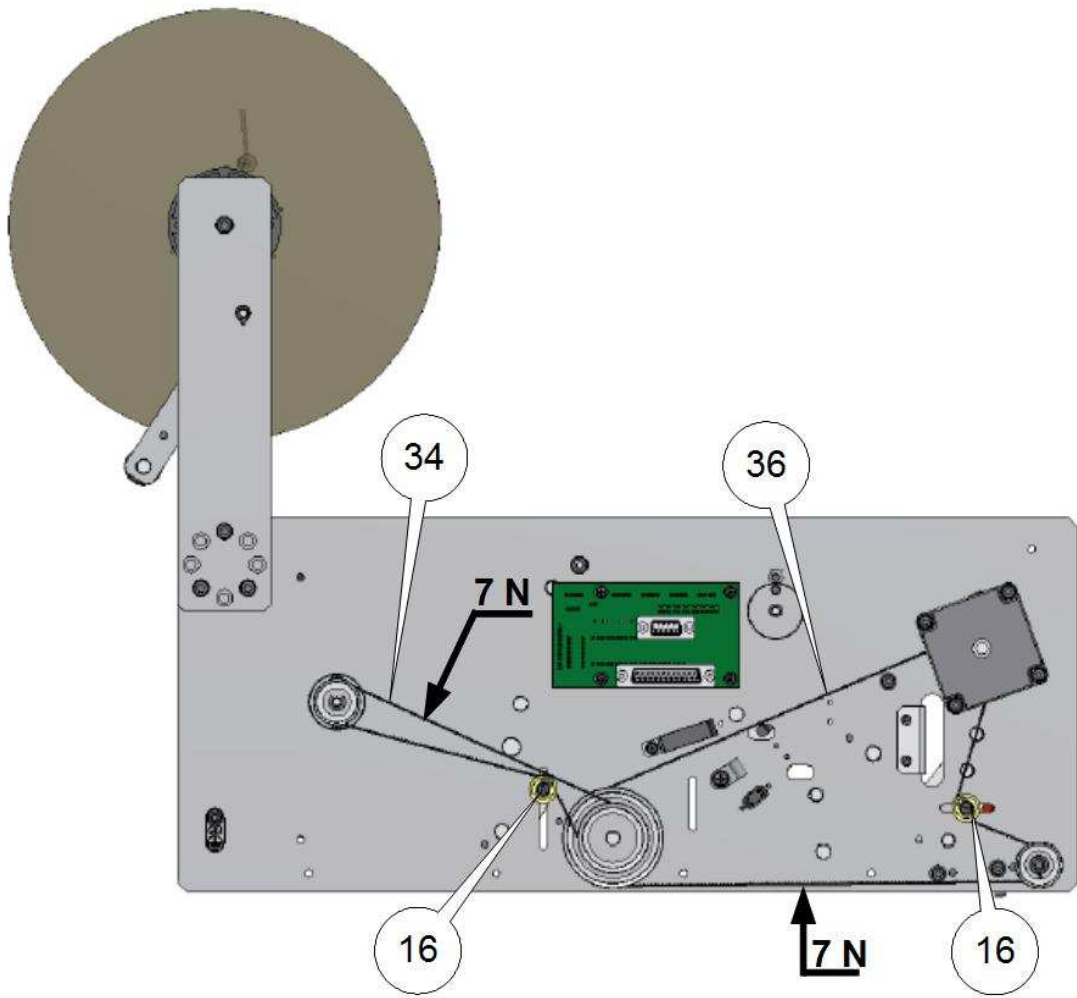

PICTURE 10

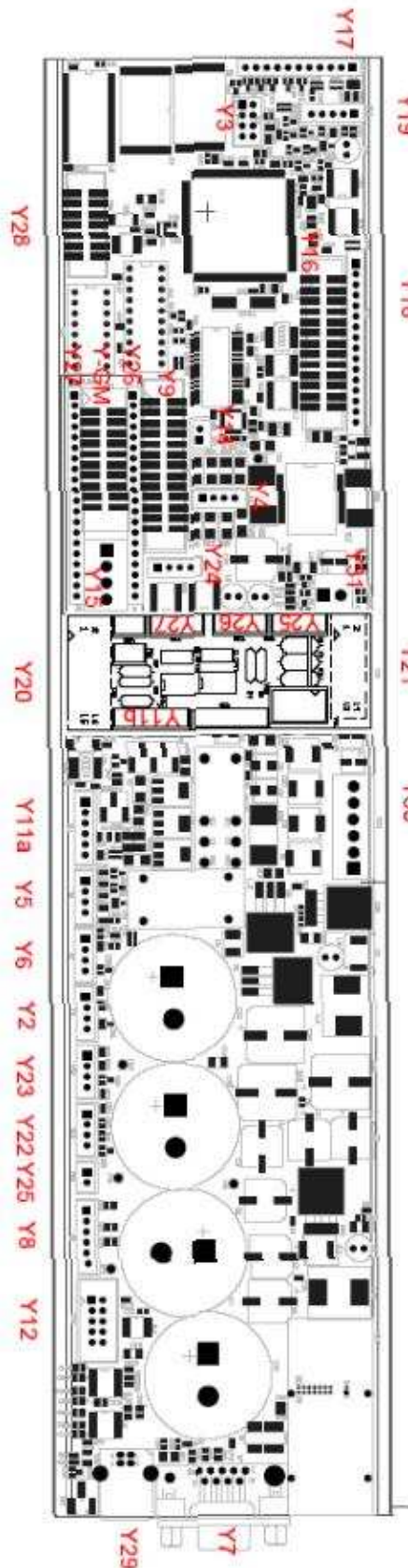

AH 870 EL7

- Y1
- Y2 Ribbon sensor
- Y3 LCD
- Y4 Motor
- Y5 Label sensor
- Y6 Label taken sensor
- Y7 Serial port
- Y8
- Y9 Thermal head
- Y10
- Y11 I/O Signals
- Y12
- Y13
- Y14 Fan
- Y15
- Y16
- Y17 Keyboard
- Y18 LCD
- Y19
- Y20
- Y21
- Y22
- Y23
- Y24
- Y25
- Y26
- Y27
- Y28
- Y29 USB
- Y30 Power supply

PICTURE 21 AH 870 LOGIC BOARD - layout

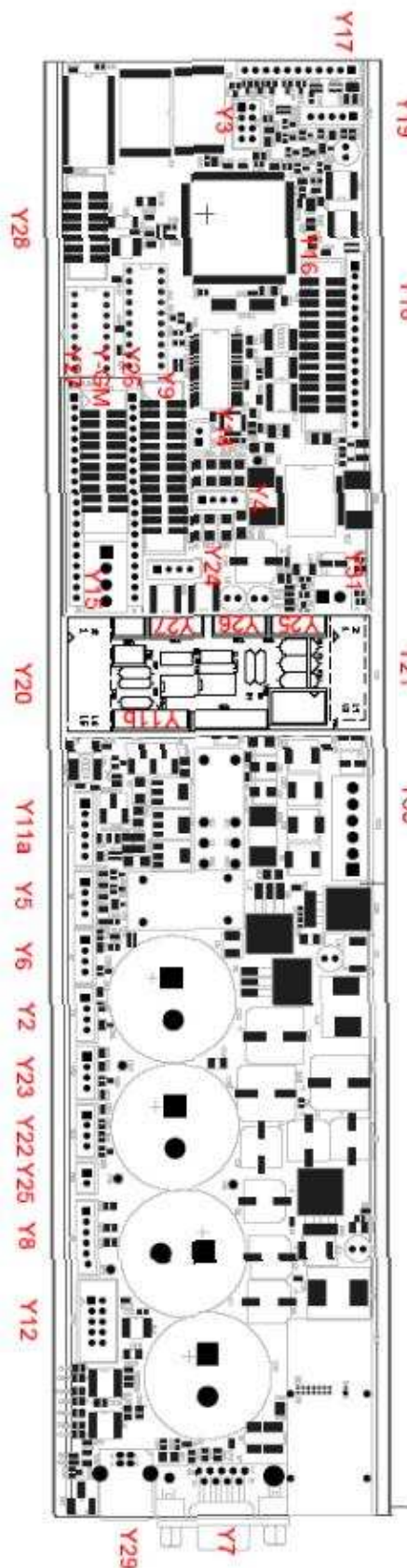

AH 871 GM EL7 AH 1271 GM EL7

- Y1
- Y2 Ribbon sensor
- Y3 LCD
- Y4 Motor
- Y5 Label sensor
- Y6 Label taken sensor
- Y7 Serial port
- Y8
- Y9
- Y10
- Y11 I/O Signals
- Y12
- Y13
- Y14 Fan
- Y15 Thermal head GM (power)
- YGM Thermal head GM (signals)
- Y16
- Y17 Keyboard
- Y18 LCD
- Y19
- Y20
- Y21
- Y22
- Y23
- Y24
- Y25
- Y26
- Y27
- Y28
- Y29 USB
- Y30 Power supply

PICTURE 21 bis AH 871 GM, AH 1271 GM LOGIC BOARD - layout

14. PART LIST AND RELEVANT PICTURES

(items are referred to following pictures)

ITEM	PART NUMBER	DESCRIPTION	AH 870 EL7	AH 871 GM EL7	AH 1271 GM EL7
1	800822960	keyboard	*	*	*
2	801665280	DIN connector assy	*	*	*
3	800925280	ring clip	*	*	*
4	801292050	filter cap	*	*	*
5	056102080	fuse 2A T	*	*	*
6	056102020	fuse 1.6A T	*	*	*
7	801292090	fuse holder	*	*	*
9	056102030	fuse 8A T	*	*	*
10	809065080	label photosensor assy	*	*	*
11	800943880	display assy	*	*	*
12	059006010	cable 25 pins, 1000 mm	*	*	*
13	800944080	power board	*	*	*
14	059006020	cable 9 pins, 1000 mm	*	*	*
15	80087700065	logic board AH 870	*		
15	80087700053	logic board AH 871 GM		*	
15	800877000B2	logic board AH 1271 GM			*
16	800925310	belt idler assy	*	*	*
17	800762090	lever	*	*	*
18	800722460	nut	*	*	*
19	061702050	bushing	*	*	*
20	800872170	connection board (printer)	*		
20	800928523	connection board GM (printer)		*	*
21	800926510	printing roller	*	*	*
22	801872020	rewinding pulley Z35	*	*	*
23	800742100	spring	*	*	*
24	800926520	peeling plate assy	*	*	*
25	800925890	lever cam	*	*	*
26	800822011	thermal print head (8 dots)	*		
26	800822720	thermal print head (8 dots GM)		*	
26	800822450	thermal print head (12 dots GM)			*
27	800944430	backing paper rewinding assy	*	*	*
28	800762350	clip holder 4"	*	*	*
29	800943500	ribbon rewinding assy	*	*	*
30	800943510	ribbon stock assy	*	*	*
31	800872180	connection board (electronic cabinet)	*		
31	800928533	connection board GM (electronic cabinet)		*	*
33	810940029	media position holder assembly	*	*	*
34	800782180	belt	*	*	*
35	800949540	driving roller assy	*	*	*
36	800782080	belt	*	*	*
37	800542410	ribbon plate	*	*	*
38	800949550	pressure roller	*	*	*
39	801622160	ribbon rewinding gear	*	*	*
40	800926220	fan assy 60 x 60 mm	*	*	*
41	801605260	fixed flange assy	*	*	*
42	051507490	printhead flat cable 26 pins	*		
42	059007040	print head flat cable 20 pins		*	*
	059007270	print head cable 4 pins (power)		*	*
43	800742210	ribbon spring	*	*	*
44	061702060	bushing	*	*	*
45	801800103	label unwind holder	*	*	*
46	801605200	movable flange assy	*	*	*
47	800926320	heat dissipater assy	*	*	*
48	801625030	ribbon photosensor	*	*	*
49	800947640	stepper motor assy 8 dots	*	*	
49	800947770	stepper motor assy 12 dots			*
50	801842501	tie rod	*	*	
51	800926560	printing roller pinion 8 dots Z28	*	*	
51	800926670	printing roller pinion 12 dots Z25			*

