

O.E.M.  
THERMAL & THERMAL TRANSFER  
LABEL PRINTERS

models

**AH 53/8 EL5**

**USER MANUAL**



Italora S.r.L. Largo Guastalla7 - 20082 Binasco - (Milano) - Italy  
phone ++39.02.90092074 - fax ++39.02.9055461

<http://www.italora.it>  
e-mail: [sales@italora.it](mailto:sales@italora.it)

## CONTENTS

1. TECHNICAL SPECIFICATIONS.....	3
2. UNPACKING .....	3
3. GENERAL VIEW.....	4
4. ROLLS COMPARTMENT DESCRIPTION.....	6
5. INCOMING INSPECTION .....	7
5.1. LABEL FORMAT SET UP PROCEDURE .....	9
6. PRINTING MEDIA DESCRIPTION .....	9
6.1. PAPER SPECIFICATIONS.....	9
6.2. THERMAL RIBBON SPECIFICATIONS.....	9
7. THERMAL RIBBON AND LABEL ROLL REPLACEMENT.....	9
7.1. THERMAL RIBBON REPLACEMENT.....	9
7.2. LABEL ROLL REPLACEMENT.....	9
8. INTERFACING .....	10
8.1. SERIAL INTERFACE.....	10
8.2. I/O SIGNALS.....	10
9. MAINTENANCE.....	11
9.1. CLEANING .....	12
10. TROUBLE SHOOTING .....	12
10.1. NO LABELS FEEDING.....	12
10.2. INCORRECT LABEL ALIGNMENT.....	12
10.3. PAPER SLIDES TO RIGHT SIDE .....	12
10.4. PRINTING WITH PATCHES MISSING.....	12
10.5. BLANK LABELS .....	12
10.6. POOR PRINTING CONTRAST .....	12
11. HARDWARE NOTES.....	13
11.1. HOW TO CHECK ELECTRONIC BOARDS .....	13
11.2. PRINT HEAD PROTECTION FUSE REPLACEMENT.....	13
11.3. THERMAL PRINT HEAD REPLACEMENT .....	13
11.4. DRIVE BELT REPLACEMENT.....	13
12. PICTURES .....	14
13. PART LIST AND RELEVANT PICTURES.....	19

Features and specifications are subject to change without notice

# AH 53/8 EL5 O.E.M. GRAPHIC LABEL PRINTERS

## 1. TECHNICAL SPECIFICATIONS

### PRINTING

Method: Direct Thermal and Thermal Transfer  
Resolution: 8 dots/mm, 384 dots/line  
Print width: 51.1 mm  
Print speed: up to 150 mm/s  
X/Y positioning of texts and bar codes  
Texts and bar codes printed in four orthogonal directions  
Lines, boxes, shadow and reverse printing  
Graphic and logos: bit image mode  
Bar Codes: EAN8, EAN13, 2/5, 2/5 I, 3/9, 2/7, DUN-14/16, UPC-A, UPC-B, UPC-E, CODE128, EAN128, Code 32, PZN, Code 93, PDF 417, Datamatrix, GS1 Databar

Automatic Check Digit computation  
Wide/narrow ratio full programmable  
Half, standard and double density  
Height programmable  
Suppression of human readable characters

Batch printing: up to 99.999.999 labels  
Layouts: 26 programmable in Flash memory, 100 fields each  
Up to 10 protection levels for variable data printing  
4 up/down 16 digits counters  
Real Time Clock

Black intensity adjustable via software  
Print button for last label repeating

### INTERFACING SIGNALS

Three optoisolated I/O

### DATA TRANSFER INTERFACE

RS232 : serial parameters settable by dip switches  
RS485 : on request

### HANDSHAKE PROTOCOL

SW : XON/XOFF

HW : DTR

### DATA TRANSMISSION

ASCII format

### CHARACTER GENERATORS

5 fixed matrix), 6 proportionals  
up to 112 customized  
(see Programming Manual for further details)  
Magnifications 9x9

### PERMANENT MEMORY

32 – bit RISC microprocessor  
4 MB flash memory  
1 MB RAM  
PCMCIA memory interface

### DETECTORS

End of paper and feeding synchronism  
End of thermal ribbon

### PRINT MEDIA

Die cut labels

### LABEL SIZES

Width: 30 mm min., 60 mm max.  
Length: 6 mm min.  
2.300 mm max.  
Key: width min.: 2 mm  
depth min.: 25 mm starting  
from the inner edge

### ROLL SIZES

Width: 30 mm min., 60 mm max.  
Outer diameter: 220 mm max.  
Core diameter: 45 mm min.

### THERMAL RIBBON

Base polyester film  
Outer diameter: length 220 meters max.  
Width: 32 mm min., 54 mm max.  
Core diameter: 25.4 mm

### PRINTER DIMENSIONS

See following pictures

Weights: 8 Kg (printer)  
7 Kg (electronic cabinet)

### POWER REQUIREMENTS

Voltage: 115/230/240 Vac; 50-60 Hz

### ENVIRONMENT

Operating temperature: 0°/ 40° C  
Storage temperature: -20°/60° C  
Humidity: 10% - 95% non-condensing

### OPTIONS

Label taken sensor

ETIK, wysiwyg label editor Windows based

## 2. UNPACKING

Open the box and check the content :

- **italora** label printer model **AH 53/8 EL5**
- Electronic Control Unit cabinet
- connection cables  
serial RS232, DB9, DB25
- 1 DIN connector 6 poles

- unwind holder and flanges
- power cable
- roll of labels
- roll of thermal ribbon
- printing tests
- CD Rom with manuals and Etik Light

### 3. GENERAL VIEW

(See picture 1)

- |      |   |  |
|------|---|--|
| 1:   | manual printing push button             |  |
| 5:   | 2 fuses 2AT (main)                      |  |
| 6:   | 1 fuse 1.6AT (logic)                    |  |
| 8:   | interfacing connector                   |  |
| 9:   | fuse 8AT (thermal head)                 |  |
| 40:  | fan                                     |  |
| 42:  | connection board                        |  |
| 44:  | I/O connector                           |  |
| 100: | <b>red led</b> =>                       | lit at POWER ON                                |
| 101: | <b>status led</b> =>                    |  |
|      | - <b>lit green:</b>                     | ON-LINE  |
|      | - <b>blinking green:</b>                | end of paper                                   |
|      | - <b>lit yellow:</b>                    | syntax error (push printing button to restart) |
|      | - <b>blinking yellow:</b>               | head temperature control active                |
| 103: | main switch                             |  |
| 104: | power cord plug                         |  |
| 106: | trimmer for black intensity fine adjust |  |
|      | - clockwise = more intensity            |  |
|      | - anticlockwise = less intensity        |  |

Electronic Control Unit 80.560.00xx - overall dimensions and fitting holes

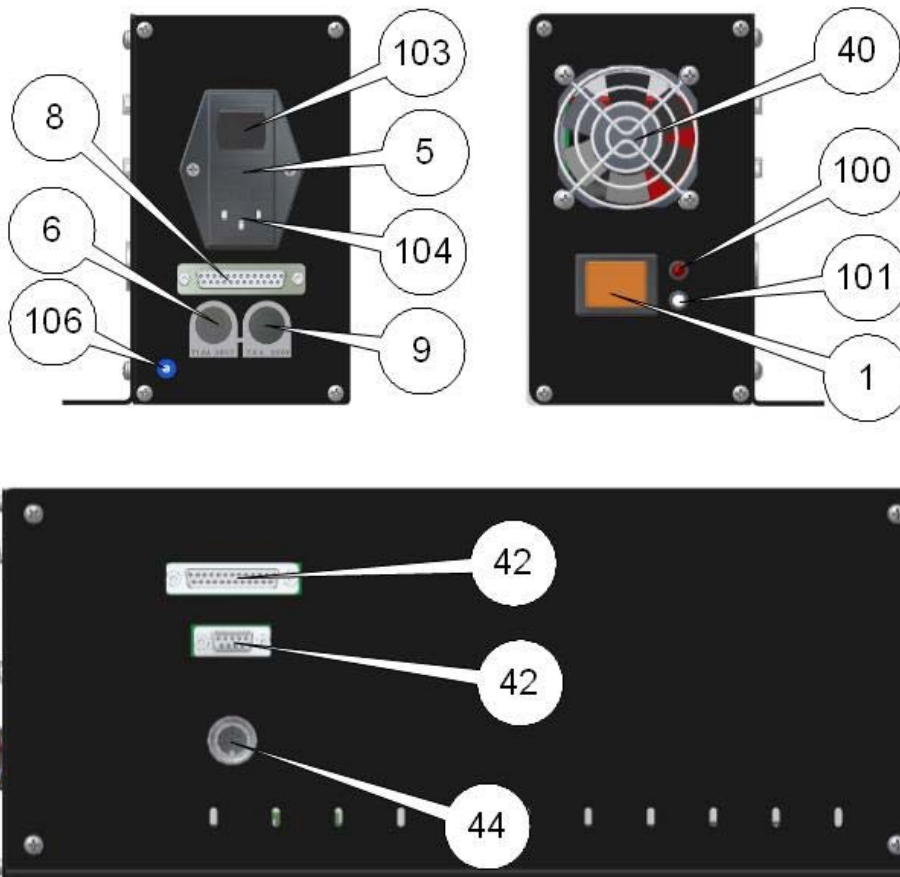

PICTURE 1

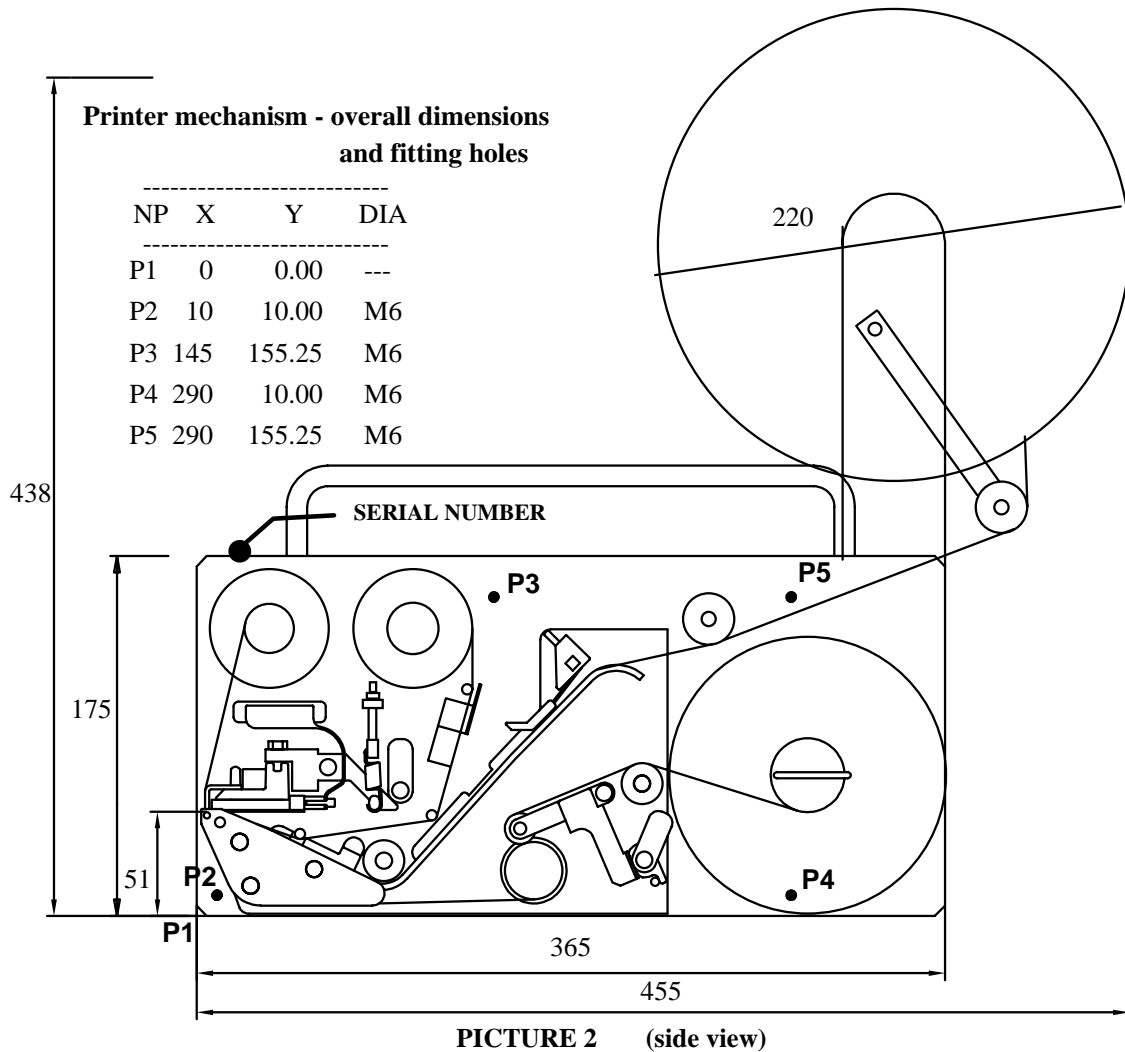
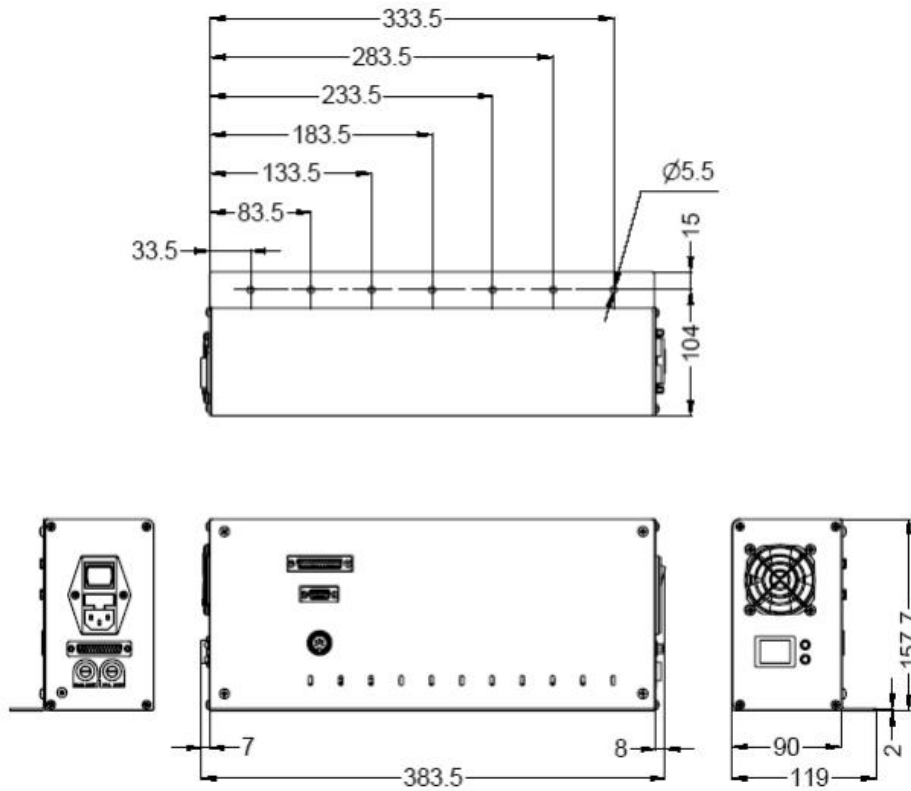

PICTURE 2 (side view)

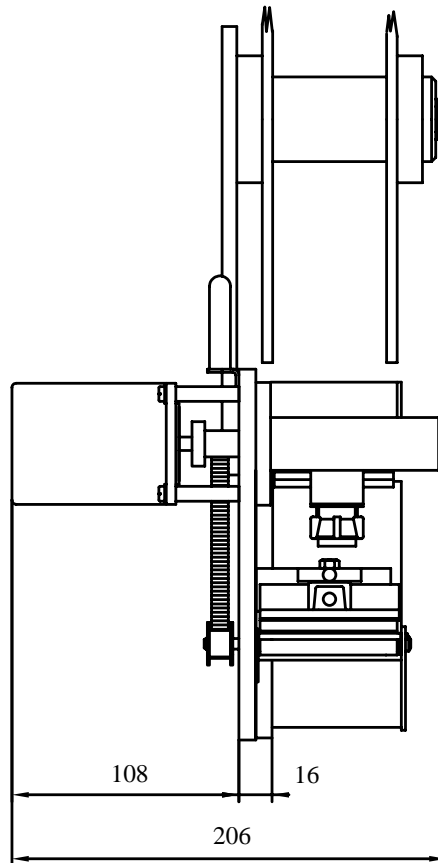

**PICTURE 3 (front view)**

#### **4. ROLLS COMPARTMENT DESCRIPTION**

(SEE FOLLOWING PICTURES)

- |  |  |
|--|--|
| 10 - photosensor for end of roll and label synchronisation | 28 - clip holder                           |
| 17 - lock / unlock toggle lever                            | 29 - thermal ribbon rewinder               |
| 17a - working position                                     | 30 - thermal ribbon stock                  |
| 17b - open position  | 32 - pressure roller                       |
| 18 - print head position fine adjustment                   | 33 - pressure clip                         |
| 21 - printing roller                                       | 35 - driving roller                        |
| 23 - print head assembly pressure spring                   | 41 - lock / unlock flange lever            |
| 25 - lock / unlock print head lever                        | 45 - label unwind holder                   |
| 25a - working position                                     | 48 - photosensor for end of thermal ribbon |
| 25b - open position  | 102 - rewinding shaft                      |
| 25c - cleaning position                                    | 105 - print head assembly                  |

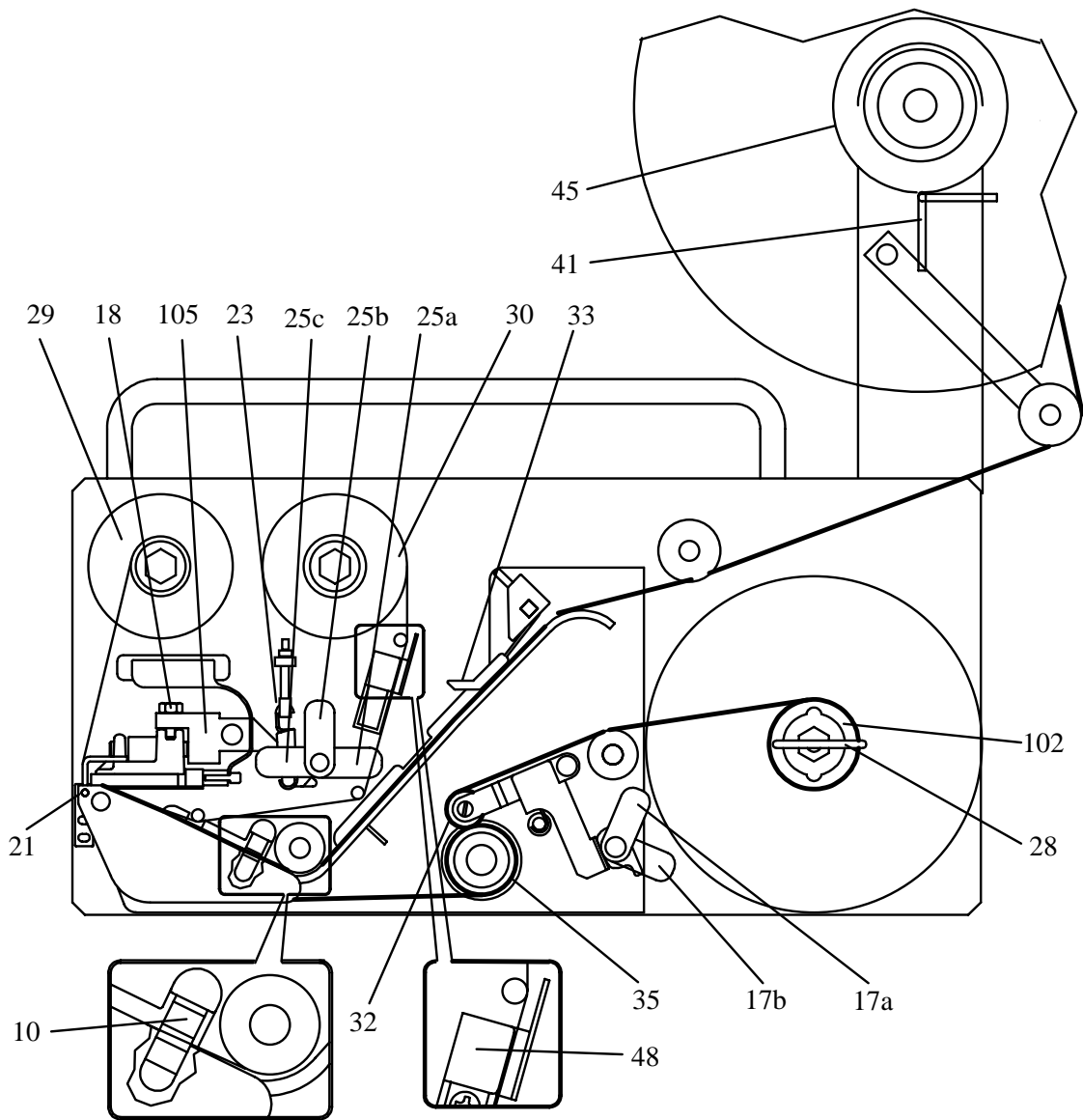

PICTURE 5

## 5. INCOMING INSPECTION

- \* Assemble the label unwind holder support and flanges as shown in picture 6, using provided three screws and three spacers.
- \* Proceed with label and ribbon loading, see chapter 7.
- \* Connect the Printer Mechanism to the Electronic Control Unit using the two provided cables.
- \* Check the correct pinout of the serial Cannon 25 pins female connector and connect the printer to the computer .
- \* For further details see chapter 8 "Interfacing".
- \* Check the voltage on the name plate next to the power receptacle.
- \* Connect the power cable to a grounded power line
- \* Switch the main switch on (rear panel)  
RED and GREEN leds ON mean operating conditions.
- \* Push the PRINT BUTTON, you will get a printing test with the FIRMWARE release information.
- \* Sending data from the computer you will get the first printing.
- \* Push the PRINT BUTTON to get the last printing again; the printer keeps the information of the last printing until next data arrive.

NOTE: **Printer retains the label length and the baking paper transparency in permanent memory. In case of change of print media see the following paragraph.**

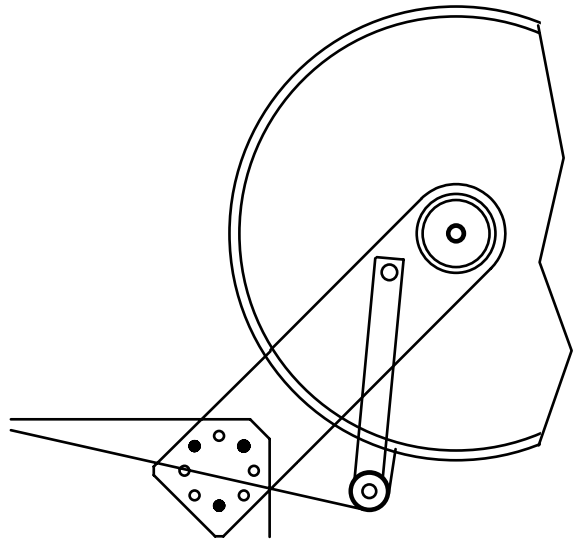
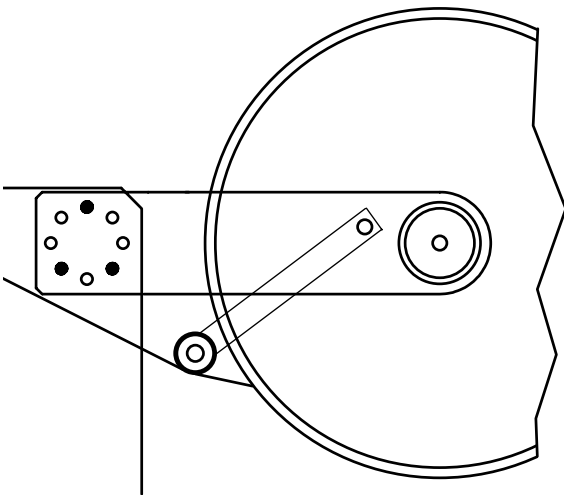
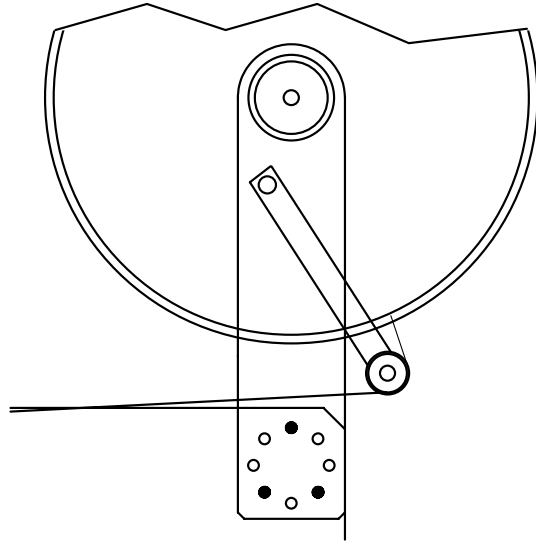
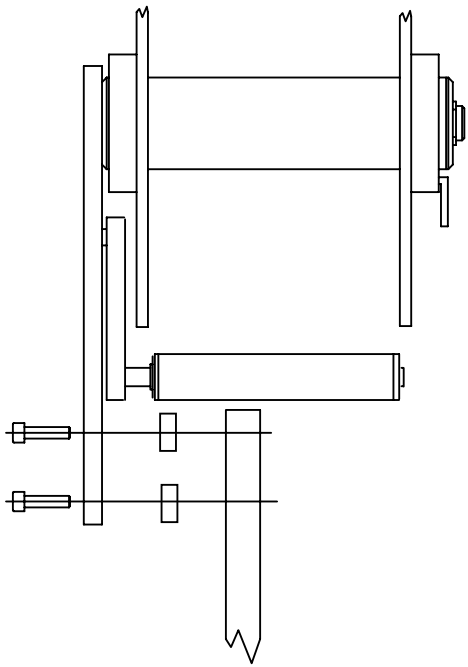

PICTURE 6

## 5.1. LABEL FORMAT SET UP PROCEDURE

(SEE PICTURES 5 and 7)

The printer retains the label length and the backing paper transparency in permanent memory.

### If changing label format or print media type

you have to use the following procedure to update the values (see also paragraph 7.2):

- 1 - Switch the printer off.
- 2 - Lift the printing head up by rotating lever #25b.
- 3 - Thread the web between the printing roller and the printing head #21,105.
- 4 - Lift the pressure roller up by rotating lever #17b.
- 5 - Thread the web between the driving roller and the pressure roller #35,32 up to the rewinding

shaft #102.

- 6 - Check web has been rightly positioned under the label photosensor #10.
- 7 - Lift the printing head and the pressure roller down by rotating levers #25a and #17a.
- 8 - Switch the printer on while pushing the print button.
- 9 - Printer ejects some labels (depending on their length) and stores the values of the media.
- 10 - Release the print button.
- 11 - The green led lit and the printer is ready to work.

## 6. PRINTING MEDIA DESCRIPTION

### 6.1. PAPER SPECIFICATIONS

White coated glossy printing paper

- weight: 65 ÷ 90 g/mq (ISO536)
- caliper: 0,075 ÷ 0,083 mm (ISO534)

### ADHESIVE SPECIFICATIONS

- peel adhesion(90° C): 430 N/m
- service temperature: -20° C ÷ + 70° C

### LINER SPECIFICATIONS

- BG 40 brown, supercalendered glassine
- weight: 65g/mq (ISO536)
- caliper: 0.057 mm (ISO534)
- transparency: 45%

### SUGGESTED MODELS

- Fasson Fastthermal NT
- Kanzaki KPT 86-H
- Fasson Fastransfer MP - S470 (TT models)
- Fasson Fastransfer Extra - S470 (TT models)

LABEL DIMENSIONS See Chapter 1

### 6.2. THERMAL RIBBON SPECIFICATIONS

- film thickness 4.5 ÷ 6 micron
- core diameter: 25.4 mm
- width: 32 mm min/ 54 mm max.
- length: about 220 meters
- ink coating outside

### SUGGESTED MODELS

- TOIKO C 250 (matt paper)
- TOIKO CR 150 (glossy paper and polypropylene)
- TOIKO R 300 (plastic media)

### STORAGE

Keep labels and ribbons in a dry place at temperature not over 40° C and not exposed to direct sun light.

## 7. THERMAL RIBBON AND LABEL ROLL REPLACEMENT

### 7.1. THERMAL RIBBON REPLACEMENT

(SEE PICTURE 7)

Remove the used roll. Remove the core #47 from the shaft #30 and put it on the rewinder #29.

By rotating the lever #25b, lift the printing head #105 from the printing roller #21, setting the movement of the ribbon free.

Slide new ribbon #43 onto shaft #30 and thread it under the ribbon photosensor #48 and the threaders #108, 107 and 37 and up round to the rewinder #29. Attach the ribbon leader with label/tape to core #47. Return head lever to closed position #25a

### 7.2. LABEL ROLL REPLACEMENT

(SEE PICTURE 5)

In case of changing of label format or printing media type, remember to follow the "Label format set up procedure" shown on paragraph 5.1.

Remove the movable flange by rotating the lever #41. Remove the empty label roll.

Insert new label roll onto roller #45

Reassemble the movable flange and push it tightly against the side of the label roll; lock lever #41.

By rotating the lever #25b, lift the printing head #105 from the feed roller #21, setting the movement of labels and ribbon free.

By rotating the lever #17b, lift the pressure roller #32 from the driving roller #35.

Remove clip #28 from the rewinding shaft #102.

Remove backing paper from the rewinding shaft.

Remove the first 50 centimetres from liner of the new roll labels.

Hold pressure clip #33 up and feed the liner through the path, thread the web between the printing roller and the thermal head #21,105, then around the driving roller and under the pressure roller #35,32, finally slide the liner on the rewinder unit #102 and fasten it with the clip holder #28.

Turn the rewinder to stretch the paper.

Turn head lever and toggle lever back to closed positions #25a,17a.

Check paper has been rightly positioned under the label photosensor #10.

Check pressure clip #33 has been positioned between centre and outer side of the label.

**WARNING: Italora OEM printer mechanisms must operate only in peel-off mode with backing paper rewound by toggle lever rollers. Any other print mode (strip form, tear-off, etc.) is not allowable and cause an incorrect paper feeding and bad printout quality.**

## 8. INTERFACING

### 8.1. SERIAL INTERFACE

Electronic Control Units 80.560.00xx for **AH53/8 EL5** printer mechanisms have a RS232 hardware interface (RS485 on request). Provided on board connector is a Cannon 25 pins "DB" female cabled as shown in the following pictures.

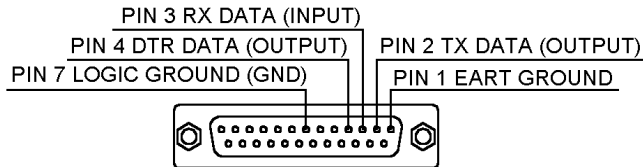

#### COMPUTER CONNECTOR WITH 9 PINS

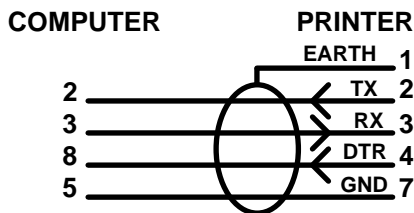

COMPUTER CONNECTOR:

- using sw protocol XON/XOFF:  
short together PINS 7-8 and 1-4-6.
- using hw protocol DTR:  
short together PINS 1-4-6.

#### COMPUTER CONNECTOR WITH 25 PIN

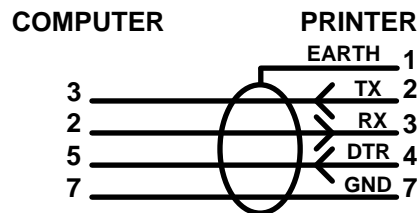

COMPUTER CONNECTOR:

- using sw protocol XON/XOFF:  
short together PINS 4-5 and 6-8-20.
- using hw protocol DTR:  
short together PINS 6-8-20.

### 8.2. I/O SIGNALS

Electronic Control Units 80.560.00xx are provided of three optoisolated lines for I/O signals: one input and two outputs. A six pins DIN connector type GPE/DIN 40040 is present cabled as follows.

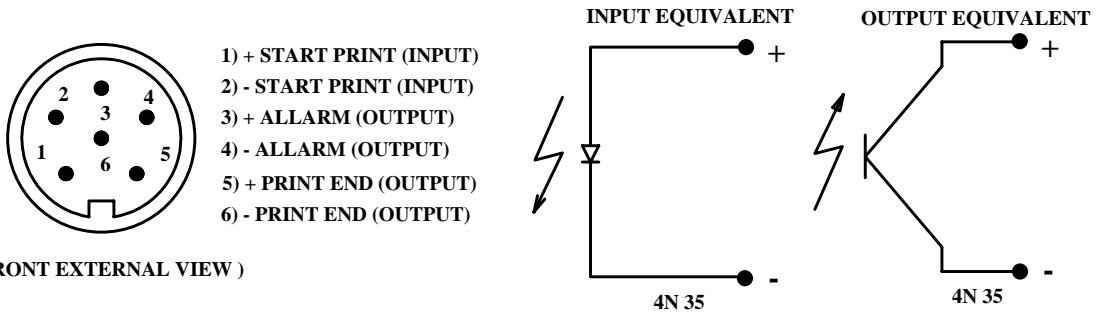

( FRONT EXTERNAL VIEW )

**PRINT END output** signal is a 250 milliseconds active pulse (optotransistor in conduction) when printer has finished to eject a printed label. This signal is commonly used to get one of our printers interfaced with automatic systems, such as appliers. It can be programmed in two different ways with the “?66&” software command (see “**PROGRAMMING MANUAL**”):

\* “?66&0” standard behaviour: a pulse of 250 msec is driven as soon as the feeding of a label has been completed. In these 250 msec (optotransistor in conduction state) the signal goes from the high level (4.4V) to the low level (0.8 V).

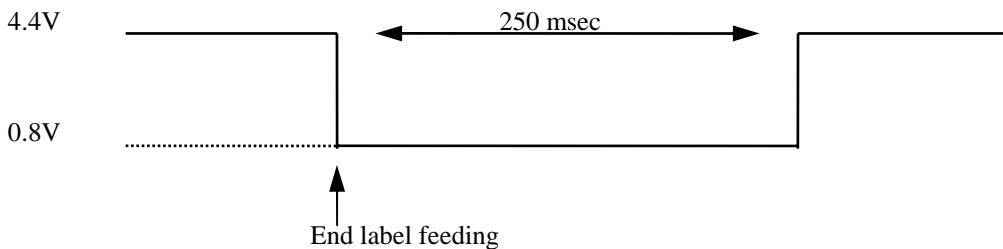

In this case the delay between a label and its next is, obviously, at least 250 msec.

\* “?66&I” : the pulse is driven (optotransistor in conduction state) during the whole label feeding so, in this period, the signal goes low.

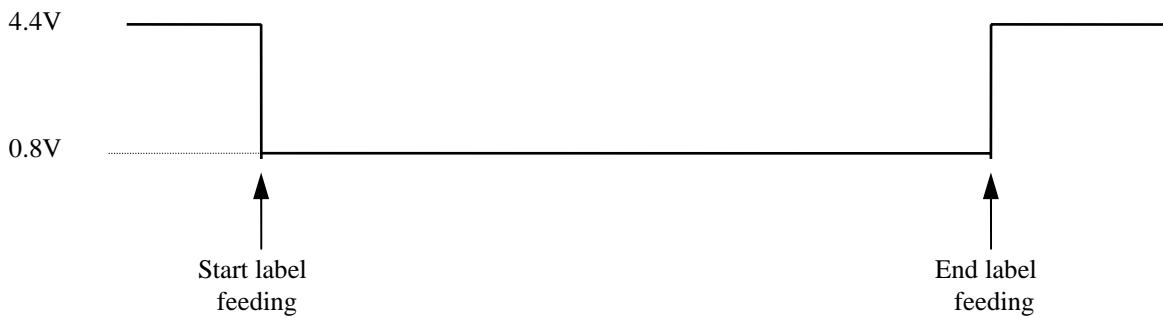

The electronic circuit is like this:

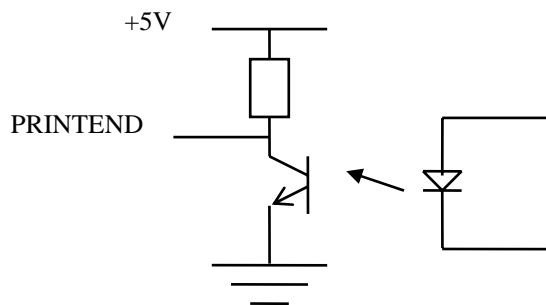

**ALARM output (OUTAUX)** signal is a level output becoming active (optotransistor in conduction) when printer detects an alarm condition: it remains active until alarm condition is present.

In end of paper or end of ribbon condition, together with the traditional led blinking, this auxiliary signal goes low and it stays there until you put the printer well again.

With your software you can program this signal in two different ways (see “**PROGRAMMING MANUAL**”):

\* *disabled signal* (default): the signal level is always high (4.4 V).

\* *enabled signal*: you can choose this possibility with the “?64&” software command; the signal goes low for the next 250 msec after the command decoding.

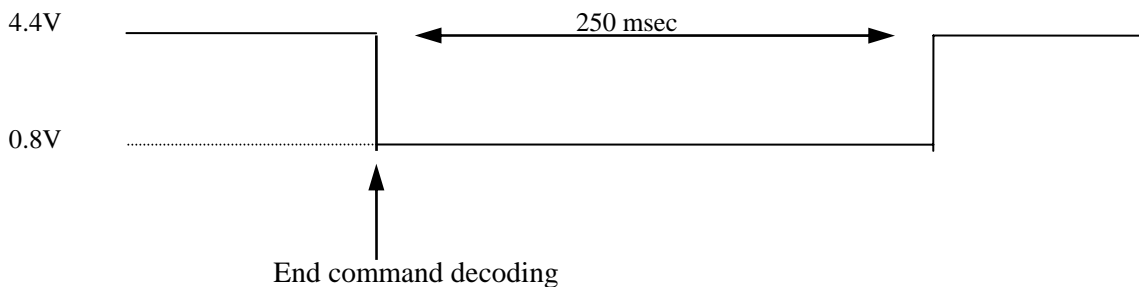

The electronic circuit is like this:

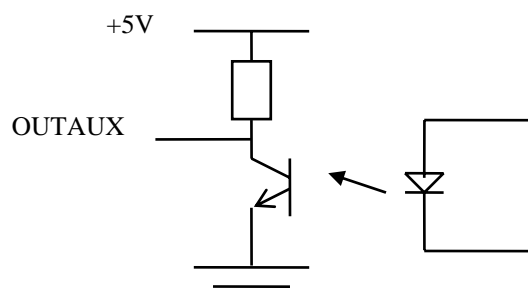

**START PRINT input** signal is activated by Set Up menu. For more information see “**PROGRAMMING MANUAL**”.

Meaning of START PRINT input is “print enable”: printer will not print any label, as after an Host computer command or as after a Print Button pushing, until START PRINT is active for at least 50 milliseconds. For every ejected label a 50 milliseconds minimum active pulse is required. Otherwise, after a pulse on this input, the printer will print only if a previous print or batch command was received, or a Print Button pushing was executed.

## 9. MAINTENANCE

WHEN NOT IN USE:

- SWITCH OFF POWER
- ALWAYS LIFT UP THE PRINTHEAD AND THE TOGGLE LEVER MECHANISM

## 9.1. CLEANING

### Print Head

- Turn the power off.
- Wait until thermal head cools down.
- Lift the print head by using the lever on position 25c
- Remove labels and thermal ribbon.
- Moisten a cotton cloth with denatured alcohol.
- Polish the below side to remove incidental adhesive traces or parts of labels
- Wait until dry before use

**WARNING: never use hard tools as this may damage the print head.**

**Rubber feeding roll:** use alcoholic detergents.

**Photosensor:** use a soft brush.

**Metallic and plastic parts:** use a soft cloth with water-based detergent (weak).

**Removing adhesive traces or parts of labels:** use alcoholic detergents. Be careful the liquid does not drip on the electronic compartment.

## 10. TROUBLE SHOOTING

### 10.1. NO LABELS FEEDING

Four situations may occur.

a) RED led is OFF, check (pict.1,#100):

- main voltage
- main switch (pict.1,#103) ON.
- main connector (pict.1,#104) plugged in
- main fuses (pict.1,#6) intact.

b) RED led is ON, STATUS led is BLINKING GREEN, check:

- label roll is not used up.
- paper position under the photosensor (pict.5,#10)

c) RED led is ON, STATUS led is BLINKING alternately GREEN and YELLOW, check:

- thermal ribbon is not used up.
- thermal ribbon position under the photosensor (pict.5,#48).

d) RED led is ON, STATUS led is BLINKING YELLOW:

- head temperature control active, printer stops until temperature has fallen to normal values.

### 10.2. INCORRECT LABEL ALIGNMENT

Make sure that:

- print head is closed (pict.5,#25a)
- toggle lever is closed (pict.5,#17a)
- paper position under the photosensor (pict.5,#10)
- backing paper is correctly rewound (pict.5,#102)
- pressure clip (pict.5,#33) is positioned

- between centre and outer side of the label.
- movable flange is tightly pushed against the side of the label roll with the lever (pic.5,#41) in lock position.

See also "Label format set up procedure" paragraph 5.1

### 10.3. PAPER SLIDES TO RIGHT SIDE

Check whether:

- pressure clip (pict.5,#33) is positioned between centre and outer side of the label.

- movable flange is closely positioned against the side of the label roll with the lever (pic.5,#41) in lock position.

### 10.4. PRINTING WITH PATCHES MISSING

Check whether:

- thermal print head needs cleaning (chapter 9)
- thermal ribbon unwinds correctly.

- there are creases on the rewound thermal ribbon. If so, turn the nut (pict.7,#110) clockwise, in order to increase the rewinding torque (a quarter of a turn max.) while holding the roller (pict.7,#29) still.

### 10.5. BLANK LABELS

Check whether

- the fuse (8AT) on the back panel has blown
- the print head connector is correctly plugged in

- (pict.13,#112) with polarity key up.
- thermal ribbon is correctly positioned, opaque surface on the label side.

### 10.6. POOR PRINTING CONTRAST

- See Electronic Control Unit rear panel.
- turn the print head screw (pict.1,#106) for temperature fine adjustment :  
clockwise to make print darker.  
anticlockwise to make print lighter.

Otherwise use the software command ?77& (see Programming Manual).

**BEWARE:** continual high operating temperature of thermal head may reduce its working life and may also fuse the ribbon.

## 11. HARDWARE NOTES

### 11.1. HOW TO CHECK ELECTRONIC BOARDS

- **First unplug the power cable from the electronic cabinet.**
- turn the 4 front and the 4 rear screws out (pict.8a#114 - 121).
- remove front and rear panels.
- turn the 4 side screws out (pict.8a,#122 - 125).
- turn the 3 inner screws out (pict.8b,#126 - 128).
- Unplug the following connectors from CPU board (pict.21).and pull carefully off the electronic boards from the chassis
  - Y2 = ribbon photosensor
  - Y3 = leds and push button
  - Y4 = stepping motor
  - Y5 = label photosensor
  - Y7 = serial interface
  - Y9 = thermal head
  - Y10 = power supply
  - Y14 = fan
- disconnect the ground cable turning the chassis nut out
- unplug the fuses connectors and the main switch connector.

### 11.2. PRINT HEAD PROTECTION FUSE REPLACEMENT

- Thermal print head is protected by an 8 A timed fuse (pict.1,#9).

### 11.3. THERMAL PRINT HEAD REPLACEMENT

(SEE PICTURE 27)

- 1 switch the printer off .
  - 2 unplug the flat connector #112 from the print head.
  - 3 lift print head by rotating the lever #25c.
  - 4 turn the screw #130 out.
  - 5 remove the adjusting nut #18.
  - 6 pull out the print head and dissipater assembly from the pivot pin.
  - 7 turn the screw #138 out and remove the print head #26 from the dissipater.
  - 8 replace thermal head and run back steps 7 to 2.
- WARNING: pay attention to plug in correctly the thermal head connector, wrong connection causes irreversible damage to the print head functionality (pict. 13)**
- 9 in case of printing quality problems, loosen the screw #130 and turn slowly the adjusting nut in or out #18, for the best printing quality, finally lock the screw #130.
  - 10 in case of creases on the rewound thermal ribbon, loosen the screws #128,129 and adjust the plate #37 in order to obtain a correct parallelism and flatness on the rewound ribbon; finally lock the screws #128,129 (TT models).

### 11.4. DRIVE BELT REPLACEMENT

(SEE PICTURE 29)

- Loosen the relevant idler #16 to remove belt #34 or #36. Replace the belt and stretch it by the idler till you get a deflection of 4 to 6 mm when applying a force of 7 N.

## 12. PICTURES

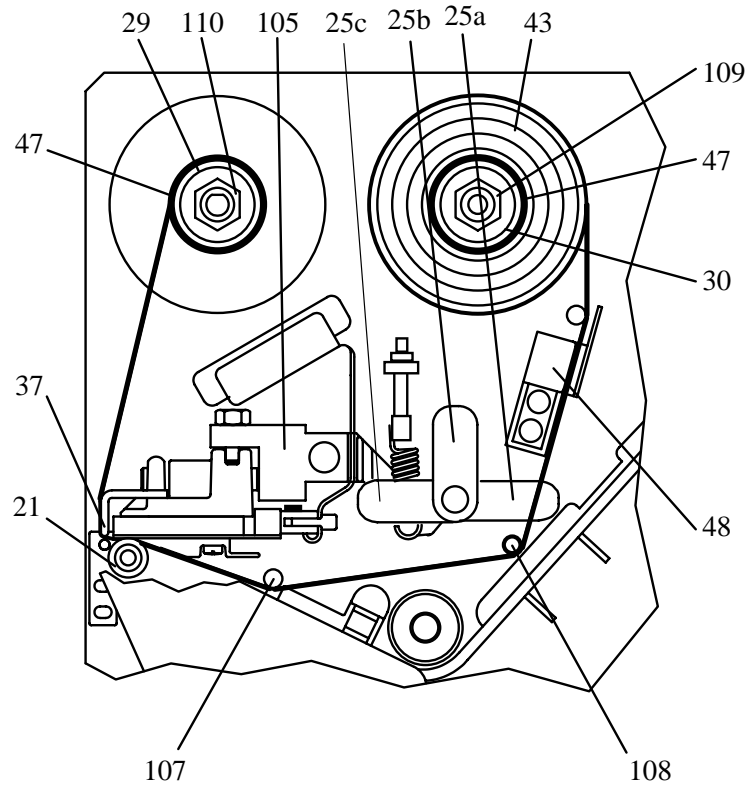

PICTURE 7

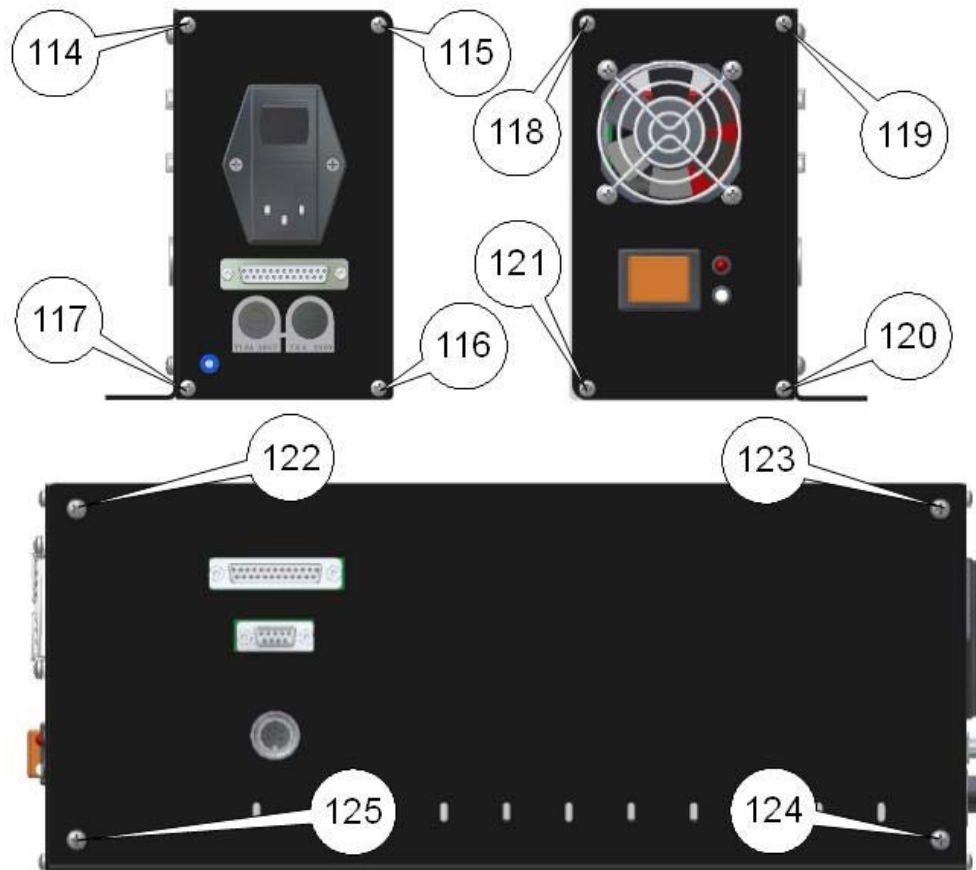

PICTURE 8a

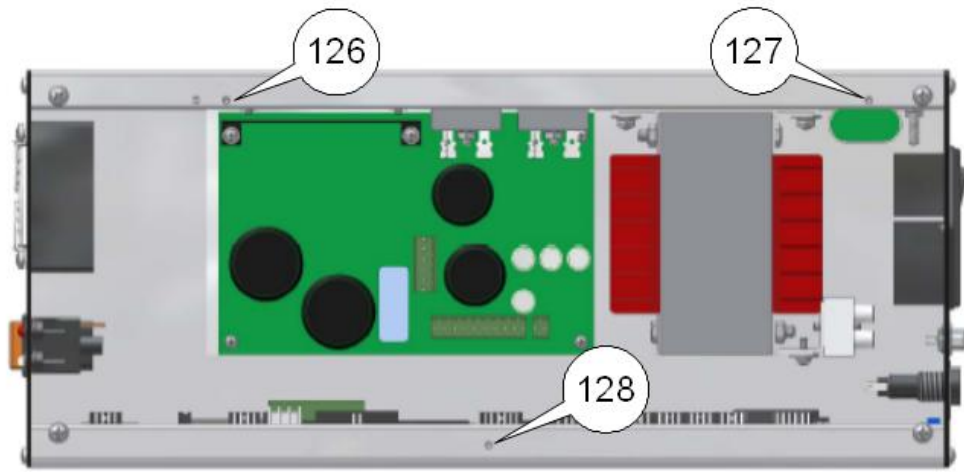

PICTURE 8b

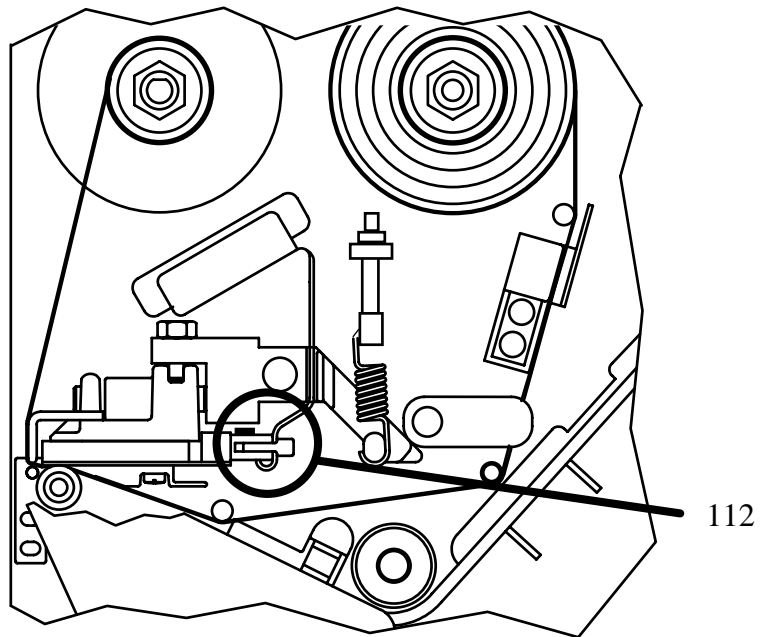

PICTURE 13

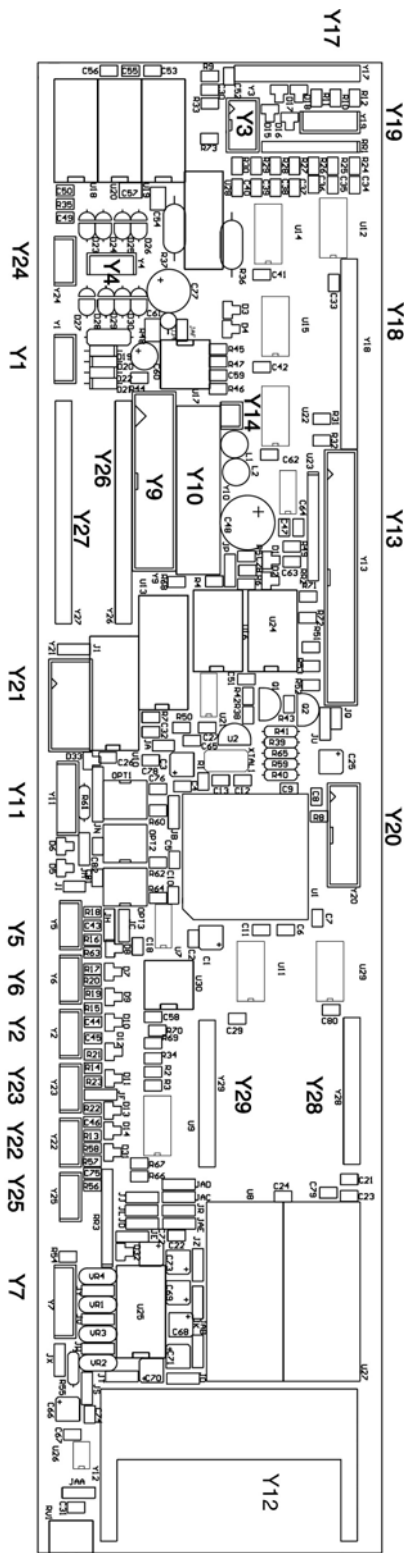

- Y1
- Y2 Ribbon sensor
- Y3 Push button, Leds
- Y4 Motor
- Y5 Label sensor
- Y6 Label taken sensor
- Y7 Serial port
- Y8
- Y9 Thermal head
- Y10 Power supply
- Y11 Optocouplers
- Y12
- Y13
- Y14 Fan
- Y15
- Y16
- Y17
- Y18
- Y19
- Y20
- Y21
- Y22
- Y23

PICTURE 21

LOGIC BOARD - layout

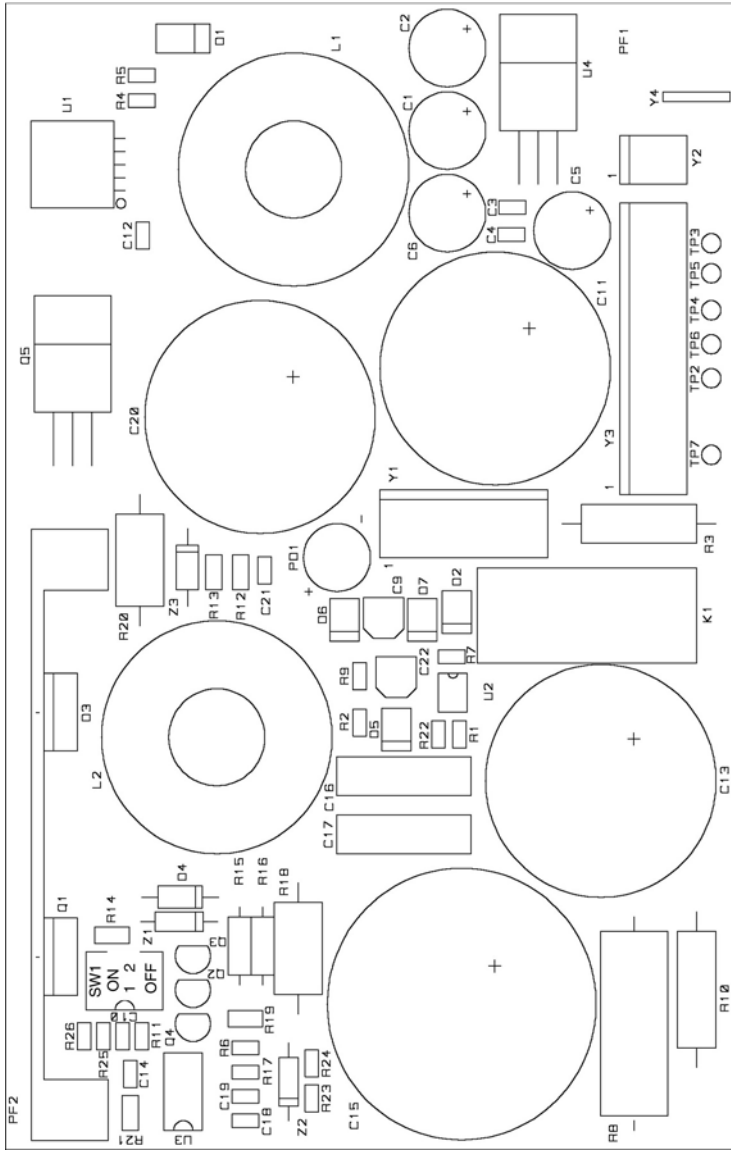

PICTURE 23 POWER SUPPLY - layout

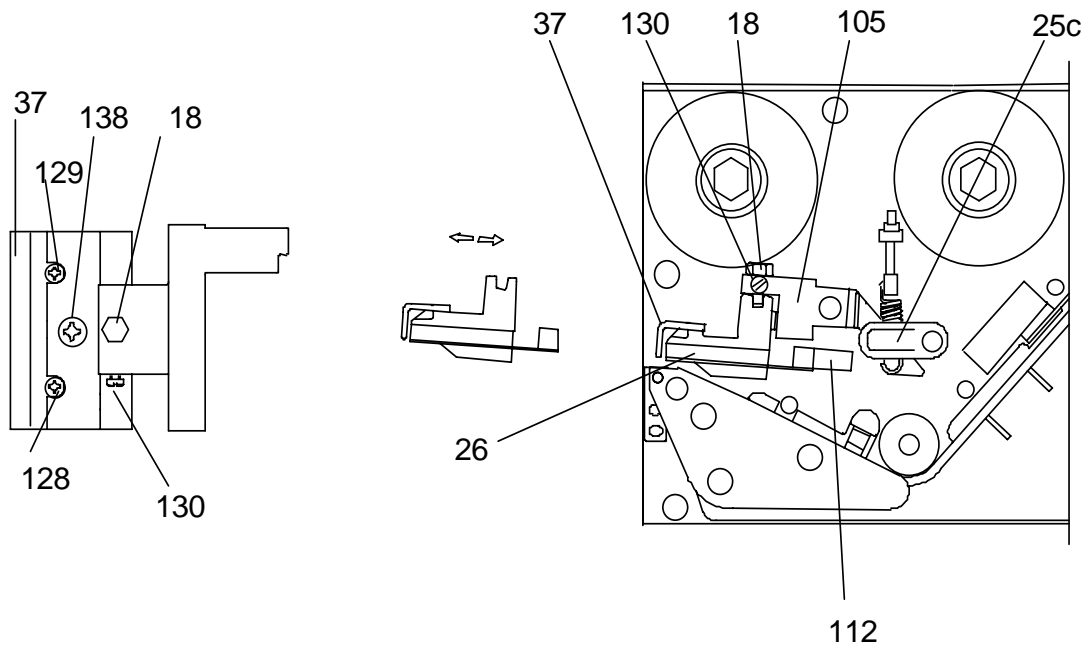

PICTURE 27

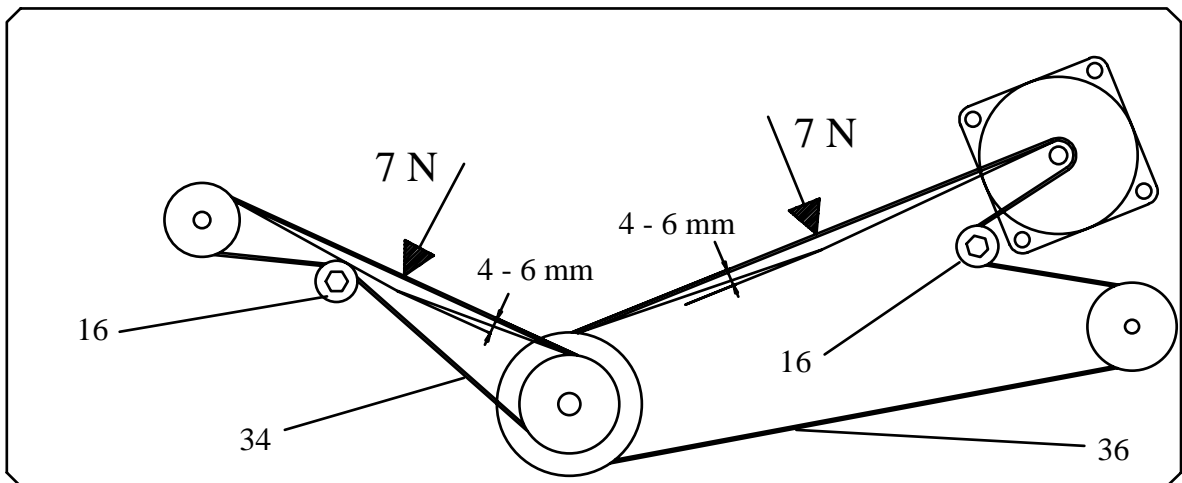

PICTURE 29

### 13. PART LIST AND RELEVANT PICTURES

(items are referred to following pictures)

ITEM	CODE	DESCRIPTION	AH 53/8 EL5 8 dots resolution
1	055002101	push button	*
2	801665280	DIN connector	*
3	800925050	printing roller plate	*
4	801292050	filter cap	*
5	056102080	fuse 2A T	*
6	056102020	fuse 1.6A T	*
7	801292090	fuse holder	*
8	801665050	RS232 connector	*
9	056102030	fuse 8A T	*
10	809065080	label photosensor assy	*
11	801665250	leds assy	*
12	059006010	cable 25 pins, 1000 mm	*
13	800945H3002	power board	*
14	059006020	cable 9 pins, 1000 mm	*
15	80087510207	logic board	*
16	800925310	belt idler assy	*
17	80076209001	lever	*
18	801312400	nut	*
19	061702050	bush	*
20	800872170	connection board (printer)	*
21	801602070	printing roller	*
22	800926630	heat dissipater assy	*
23	800742100	printhead lever spring	*
24	800926080	peeling shaft assembly	*
25	800925880	printhead lever	*
26	800822040	thermal print head (8 dots)	*
27	809032200	lever spring	*
28	809062200	clip holder	*
29	800942670	ribbon rewinding assy	*
30	800942680	ribbon stock assy	*
31	---	---	---
32	051507490	printhead flat cable	*
33	810940029	media position holder assembly	*
34	801602200	belt	*
35	800925600	driving roller	*
36	802352830	belt	*
37	801622040	ribbon plate	*
38	800502271	side panel	*
39	801622160	ribbon rewinding gear	*
40	800926220	fan assy 60 x 60 mm	*
41	801605260	fixed flange assy	*
42	800872180	connection board (electronic cabinet)	*
43	801842501	tie rod	*
44	---	---	---
45	800925720	label unwind holder	*
46	801605200	movable flange assy	*
47	---	---	---
48	801625030	ribbon photosensor	*
49	801805050	stepper motor assy	*

