

**O.E.M.  
THERMAL & THERMAL TRANSFER  
LABEL PRINTERS**

**models**

**AH 2006**

**USER MANUAL**



**Italora S.r.L. Largo Guastalla 7 - 20082 Binasco - (Milano) - Italy**  
**phone ++39.02.90092074 - fax ++39.02.9055461**  
**internet - <http://www.italora.it>**  
**E mail - [sales@italora.it](mailto:sales@italora.it)**

**rev. 03.11**

**AH 2006**

## CONTENTS

1. TECHNICAL SPECIFICATIONS .....	3
2. UNPACKING .....	3
3. GENERAL VIEW .....	4
4. ROLLS COMPARTMENT DESCRIPTION .....	9
5. INCOMING INSPECTION .....	11
5.1. LABEL FORMAT SET UP PROCEDURE .....	13
6. PRINTING MEDIA DESCRIPTION .....	13
6.1. PAPER SPECIFICATIONS .....	13
6.2. THERMAL RIBBON SPECIFICATIONS .....	13
7. THERMAL RIBBON AND LABEL ROLL REPLACEMENT .....	14
7.1. THERMAL RIBBON REPLACEMENT .....	14
7.2. LABEL ROLL REPLACEMENT .....	14
8. INTERFACING .....	11
8.1. SERIAL INTERFACE .....	11
8.2. I/O SIGNALS .....	11
9. MAINTENANCE .....	16
9.1. CLEANING .....	17
10. TROUBLE SHOOTING .....	17
10.1. NO LABELS FEEDING .....	17
10.2. INCORRECT LABEL ALIGNMENT .....	17
10.3. PAPER SLIDES TO RIGHT SIDE .....	17
10.4. PRINTING WITH PATCHES MISSING .....	17
10.5. BLANK LABELS .....	17
10.6. POOR PRINTING CONTRAST .....	17
11. HARDWARE NOTES .....	18
11.1. HOW TO CHECK ELECTRONIC BOARDS .....	18
11.2. PRINT HEAD PROTECTION FUSE REPLACEMENT .....	19
11.3. THERMAL PRINT HEAD REPLACEMENT .....	19
11.4. DRIVE BELT REPLACEMENT .....	20
12. SCHEMES .....	21
13. PART LIST AND RELEVANT PICTURES .....	23

Features and specifications are subject to change without notice

# AH 2006 GRAPHIC LABEL PRINTERS

## 1. TECHNICAL SPECIFICATIONS

### PRINTING

Method: Direct Thermal and Thermal Transfer

Resolution: 8 dots/mm 1344 dot/line

Print width: 168.0 mm

Print speed: up to 130 mm/s

X/Y positioning of texts and bar codes

Texts and bar codes printed in four orthogonal directions

Lines, diagonals, boxes, shadow and reverse printing

Graphic and logos: bit image mode

Bar Codes: EAN8, EAN13, 2/5, 2/5 I, 3/9, 2/7, DUN-14/16, UPC-A, UPC-B, UPC-E, CODE128, EAN128, Code 32, PZN, Code 93, PDF 417, Datamatrix, GS1

Databar

Automatic Check Digit computation

Wide/narrow ratio full programmable

Half, standard and double density

Height programmable

Suppression of human readable characters

Batch printing: up to 99.999.999 labels

Layouts: 26 programmable in Flash memory, 100 fields each

Up to 10 protection levels for variable data printing

4 up/down alphanumeric counters, 16 digits

Real Time Clock

Black intensity adjustable via SW

Print button for last label repeating

### INTERFACING SIGNALS

Three optoisolated I/O

### DATA TRANSFER INTERFACE

Serial RS232, serial parameters settable via software

RS485 : on request

### HANDSHAKE PROTOCOL

SW : XON/XOFF

HW : DTR

### DATA TRANSMISSION

ASCII format

### CHARACTER GENERATORS

5 fixed matrix), 6 proportionals

up to 112 customized

(see Programming Manual for further details)

Magnifications 9x9

### MEMORY

32 bit RISC microprocessor

4 MB flash memory

1 MB RAM

PCMCIA memory interface

### DETECTORS

End of paper and feeding synchronism

End of thermal ribbon

### PRINT MEDIA

Die cut labels

### LABEL SIZES

Width: 80 mm min., 180 mm max

Length: 50 mm min.

760 mm max

Key: width min.: 2 mm

depth min.: 25 mm starting from the inner edge

### ROLL SIZES

Width: 80 mm min., 180 mm max

Outer diameter: 220 mm max

Core diameter: 45 mm min.

### THERMAL RIBBON

Base polyester film, outside coated

Outer diameter: length 600 meters max

Width: 80 mm min., 180 mm max

Core diameter: 25.4 mm

### PRINTER DIMENSIONS

See following pictures

Weight: 15 Kg (printer)

9 Kg (electronics box)

### POWER REQUIREMENTS

Voltage: 115/230/240 Vac; 50-60 Hz

### ENVIRONMENT

Operating temperature: 0°/ 40° C

Storage temperature: -20°/60° C

Humidity: 10% - 95% non-condensing

### OPTIONS

Label taken sensor

ETIK wysiwyg label editor Windows based

## 2. UNPACKING

Open the box and check the content :

- **italora** label printer model **AH 2006**

- Electronic Control Unit cabinet

- Connection cables

serial RS232, DB9, DB25

- 1 DIN connector 6 poles

- unwind holder and flanges

- power cable

- roll of labels

- roll of thermal ribbon

- printing tests

- CD Rom with manuals and Etik Light

### 3. GENERAL VIEW

(See picture 1)

- |      |                                       |   |  |
|------|---------------------------------------|---|--|
| 1:   | manual printing push button           | - <b>lit yellow:</b>                      | syntax error (push printing button to restart) |
| 5:   | 2 fuses 2AT (main)                    | - <b>blinking yellow:</b>                 | head temperature control active                |
| 6:   | 1 fuse 1.6AT (logic)                  | - <b>alternate green/yellow blinking:</b> | end of ribbon                                  |
| 8:   | interfacing connector                 |   |  |
| 9:   | fuse 8AT (thermal head)               |   |  |
| 40:  | fan                                   |   |  |
| 42:  | connection board                      | 103:                                      | main switch                                    |
| 44:  | I/O connector                         | 104:                                      | power cord plug                                |
| 100: | <b>red led</b> => lit at POWER ON     | 106:                                      | trimmer for black intensity fine adjust        |
| 101: | <b>status led</b> =>                  |   | - clockwise = more intensity                   |
|      | - <b>lit green:</b> ON-LINE           |   | - anticlockwise = less intensity               |
|      | - <b>blinking green:</b> end of paper |   |  |

Electronic Control Unit 80.560.00xx - overall dimensions and fitting holes

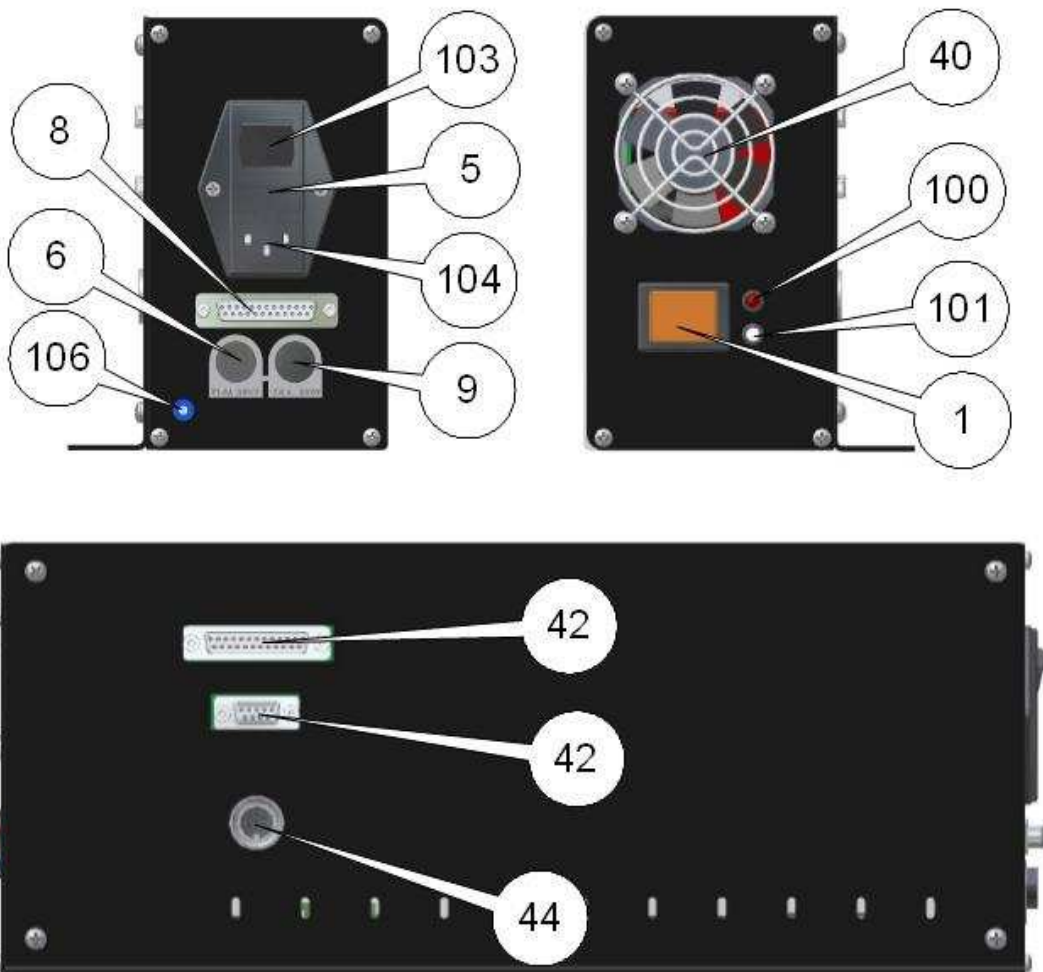

PICTURE 1

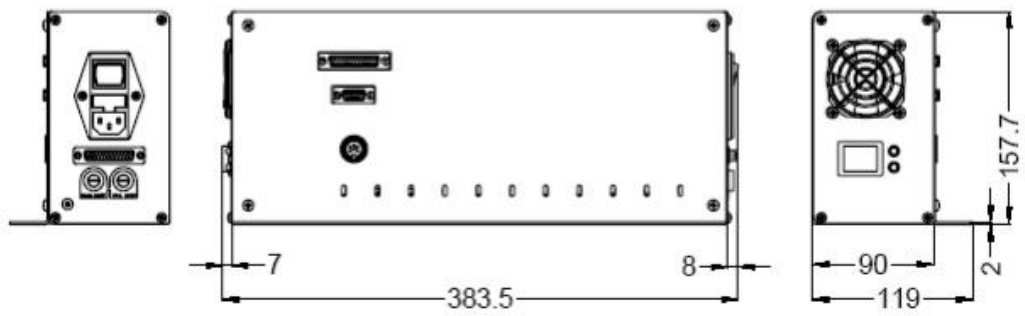
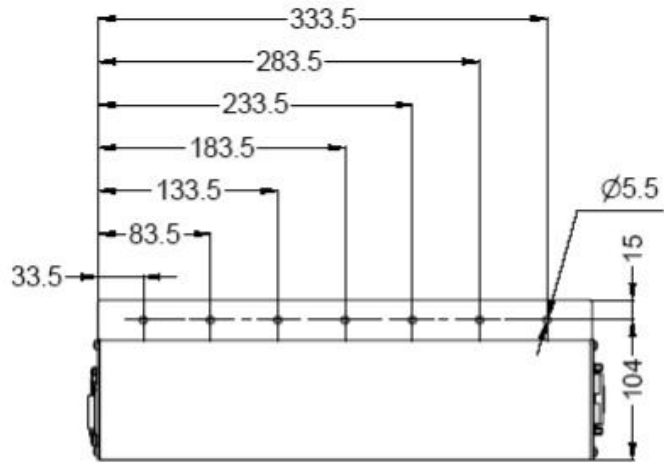



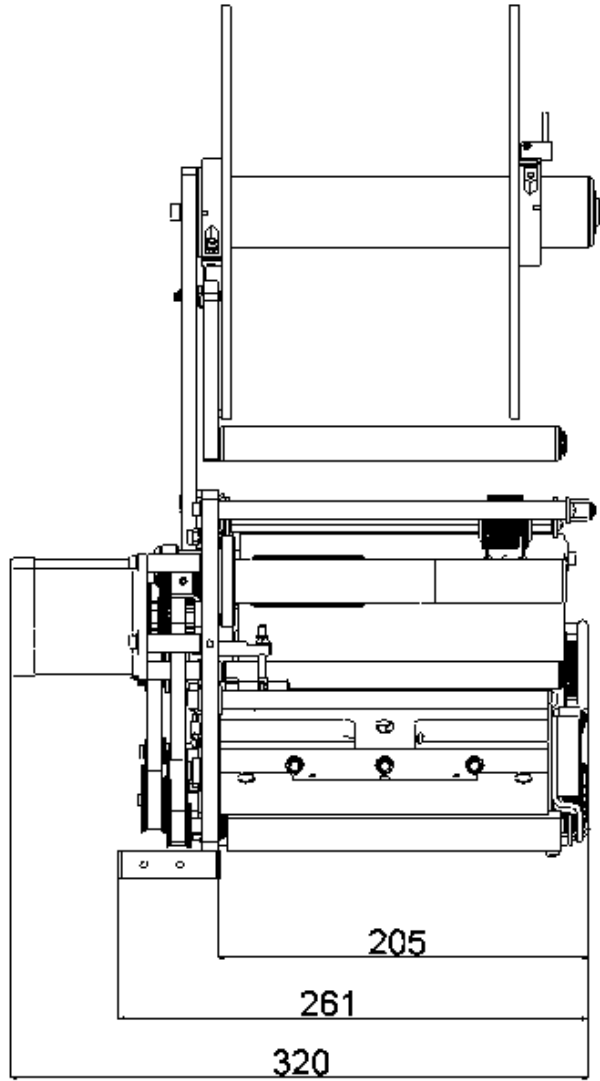

(front view)

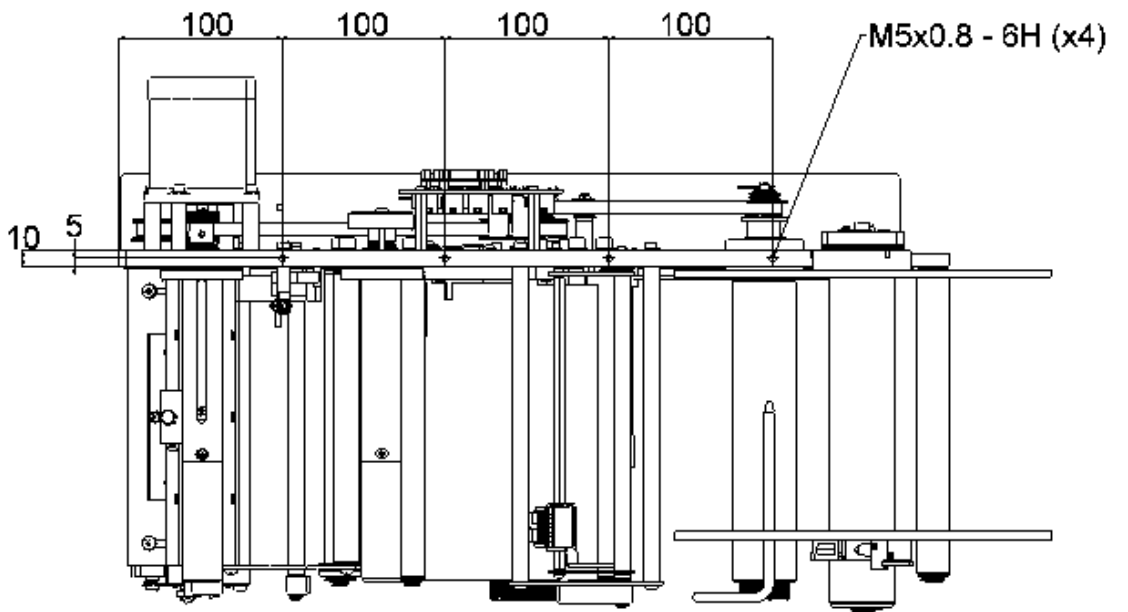

(top view)

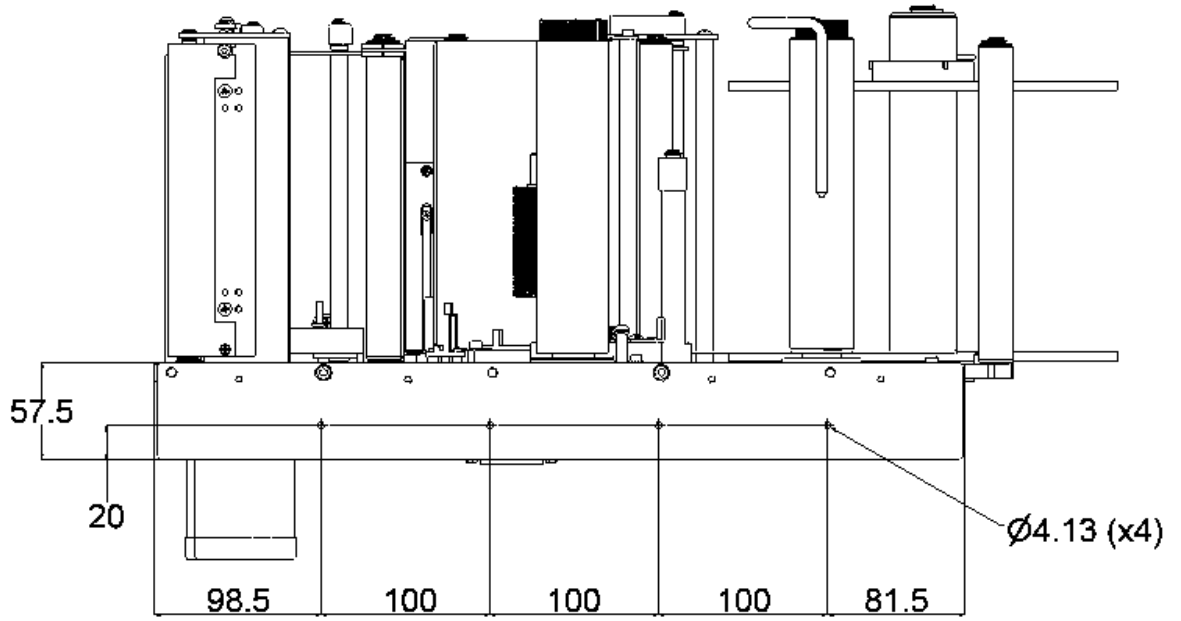

(bottom view)

#### 4. ROLLS COMPARTMENT DESCRIPTION

(SEE FOLLOWING PICTURES)

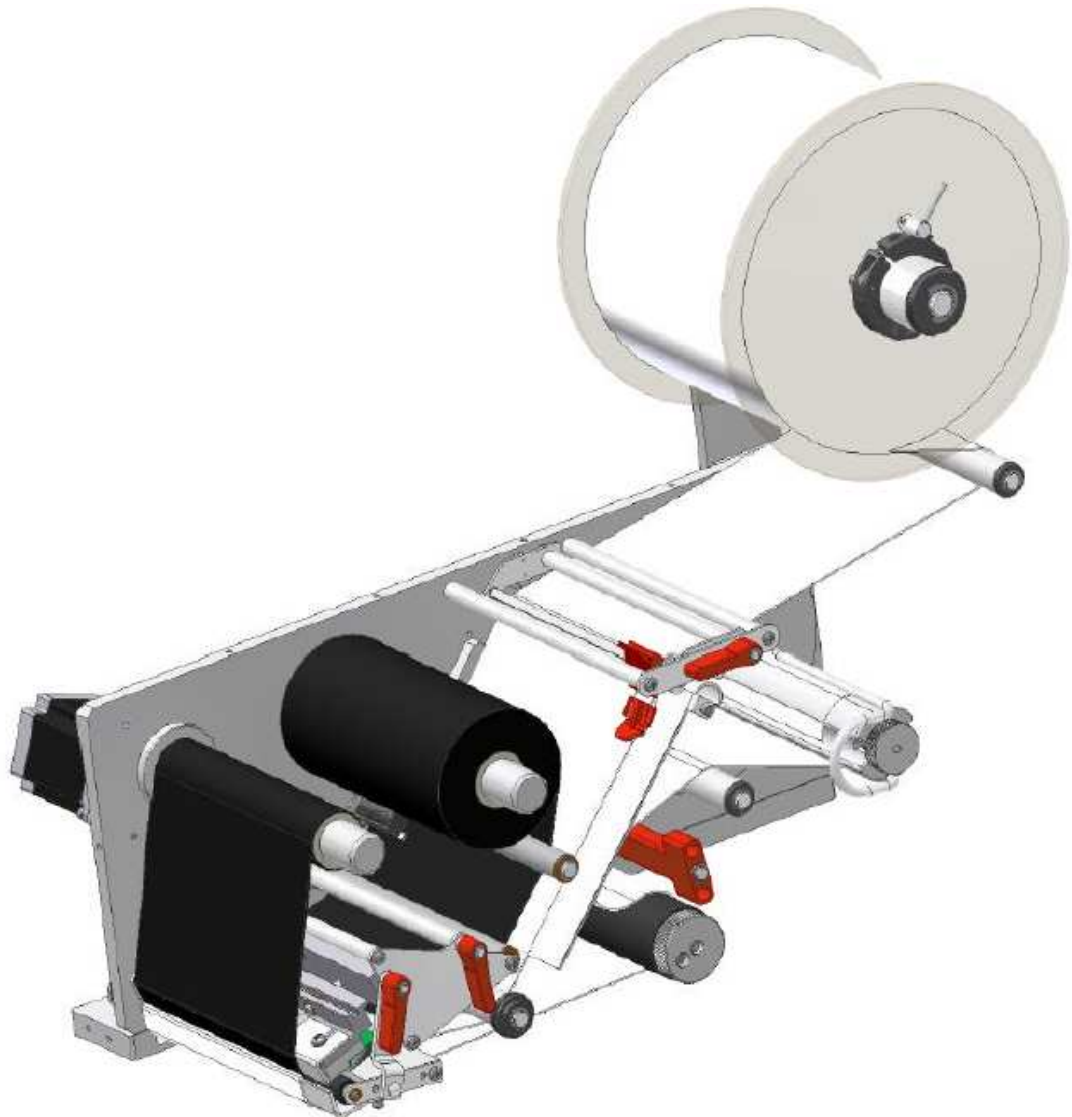

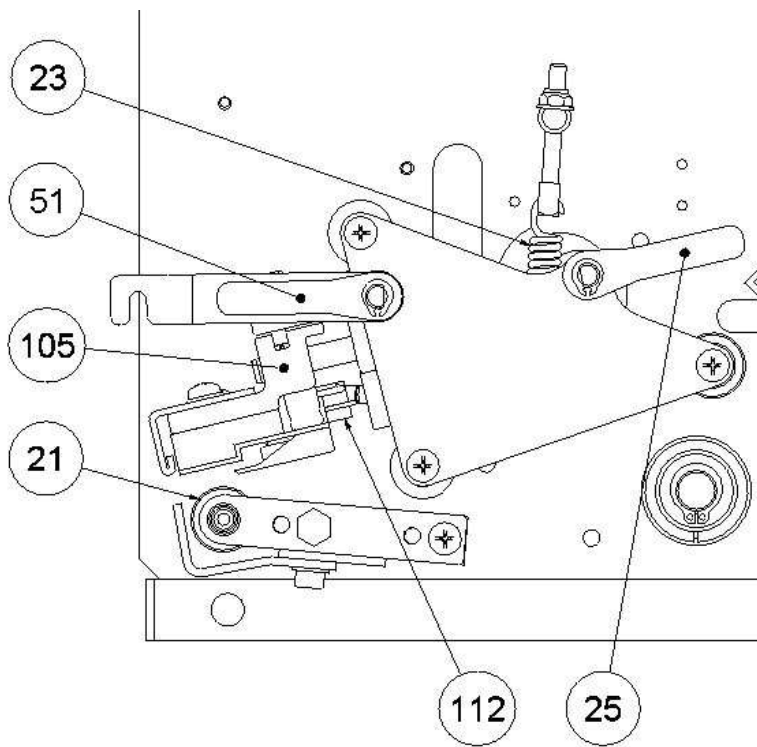

PICTURE 4

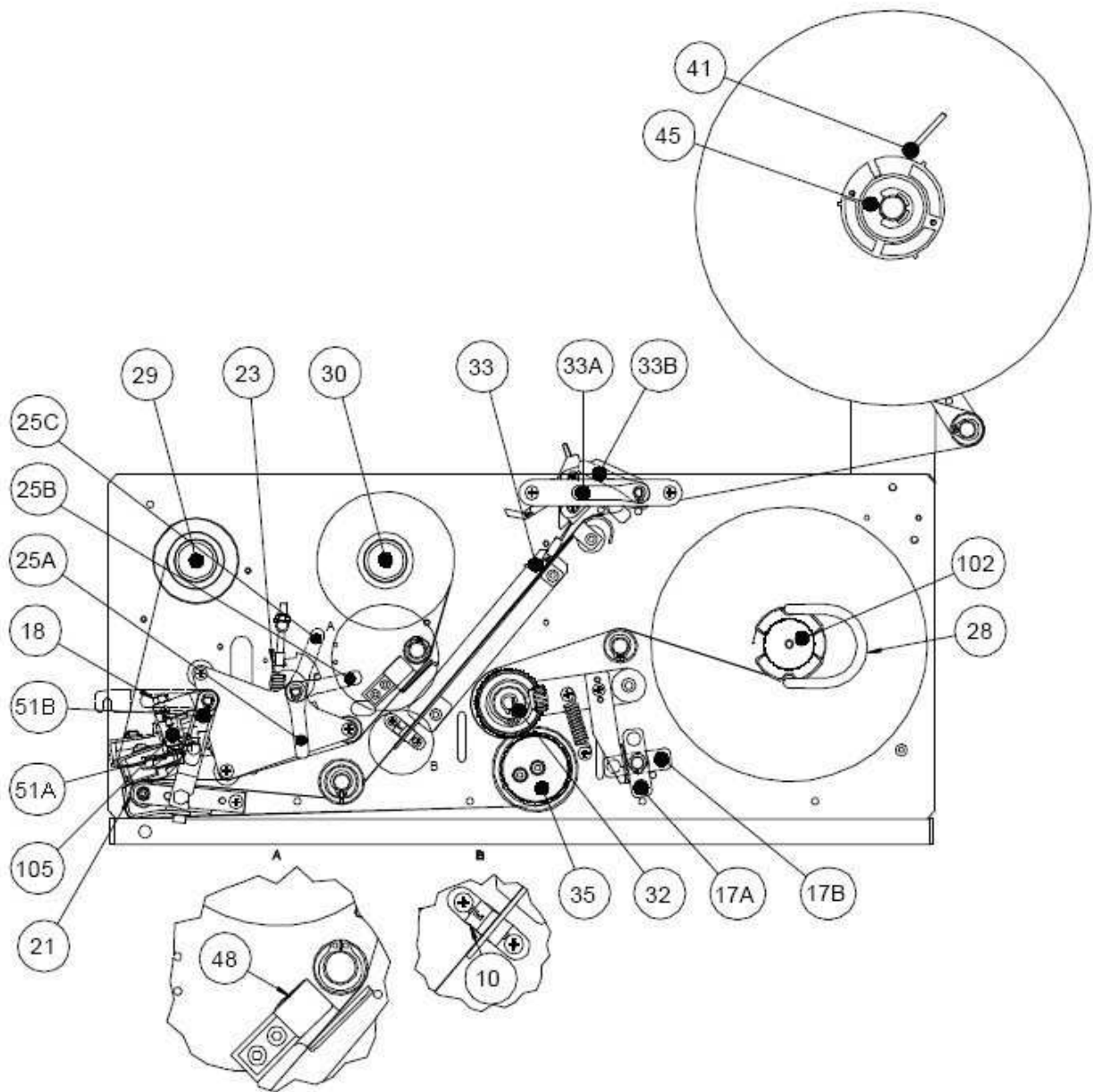

**PICTURE 5**

- |     |   |     |   |
|-----|---|-----|---|
| 10  | - photosensor for end of roll and label synchronisation | 32  | - pressure roller                       |
| 17  | - lock / unlock toggle lever                            | 33  | - pressure clip                         |
| 17a | - working position                                      | 33a | - working position                      |
| 17b | - open position   | 33b | - open position                         |
| 18  | - print head position fine adjustment                   | 35  | - driving roller                        |
| 21  | - printing roller                                       | 41  | - lock / unlock flange lever            |
| 23  | - print head assembly pressure spring                   | 45  | - label unwind holder                   |
| 25  | - lock / unlock print head lever                        | 48  | - photosensor for end of thermal ribbon |
| 25a | - working position                                      | 51  | - pressure clip                         |
| 25b | - open position   | 51a | - working position                      |
| 25c | - cleaning position                                     | 51b | - open position                         |
| 28  | - clip holder   | 102 | - rewinding shaft                       |
| 29  | - thermal ribbon rewinder                               | 105 | - print head assembly                   |
| 30  | - thermal ribbon stock                                  | 112 | - print head connector                  |

## 5. INCOMING INSPECTION

\* Assemble the label unwind holder support and flanges as shown in picture 6, using provided screws.

\* Proceed with label and ribbon loading, see chapter 7.

\* Connect the Printer Mechanism to the Electronic Control Unit using the two provided cables.

- \* Check the correct pinout of the serial Cannon 25 pins female connector and connect the printer to the computer .
- \* For further details see chapter 8 "Interfacing".
- \* Check the voltage on the name plate next to the power receptacle.
- \* Connect the power cable to a grounded power line
- \* Switch the main switch on (rear panel)  
RED and GREEN leds ON mean operating conditions.

- \* Push the PRINT BUTTON, you will get a printing test with the FIRMWARE release information.
- \* Sending data from the computer you will get the first printing.
- \* Push the PRINT BUTTON to get the last printing again; the printer keeps the information of the last printing until next data arrive.

**NOTE: Printer retains the label length and the baking paper transparency in permanent memory. In case of change of print media see the following paragraph.**

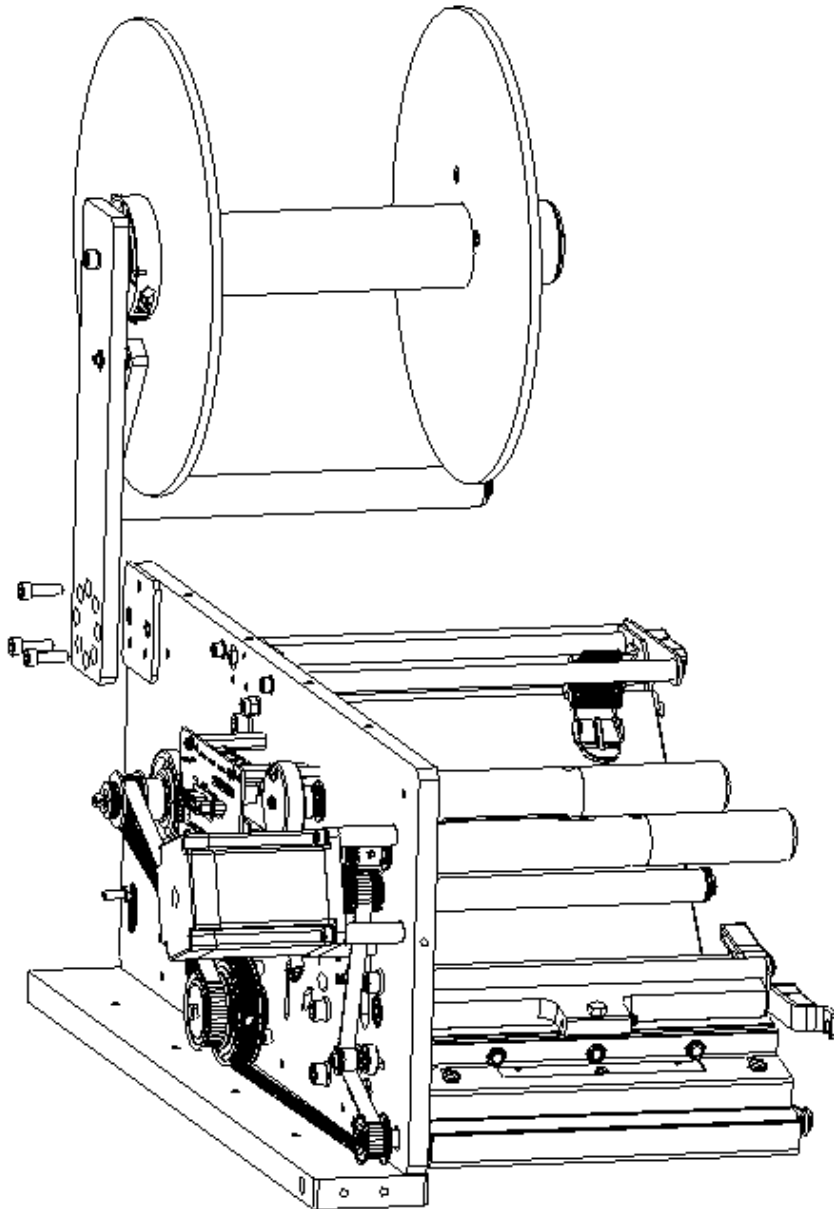

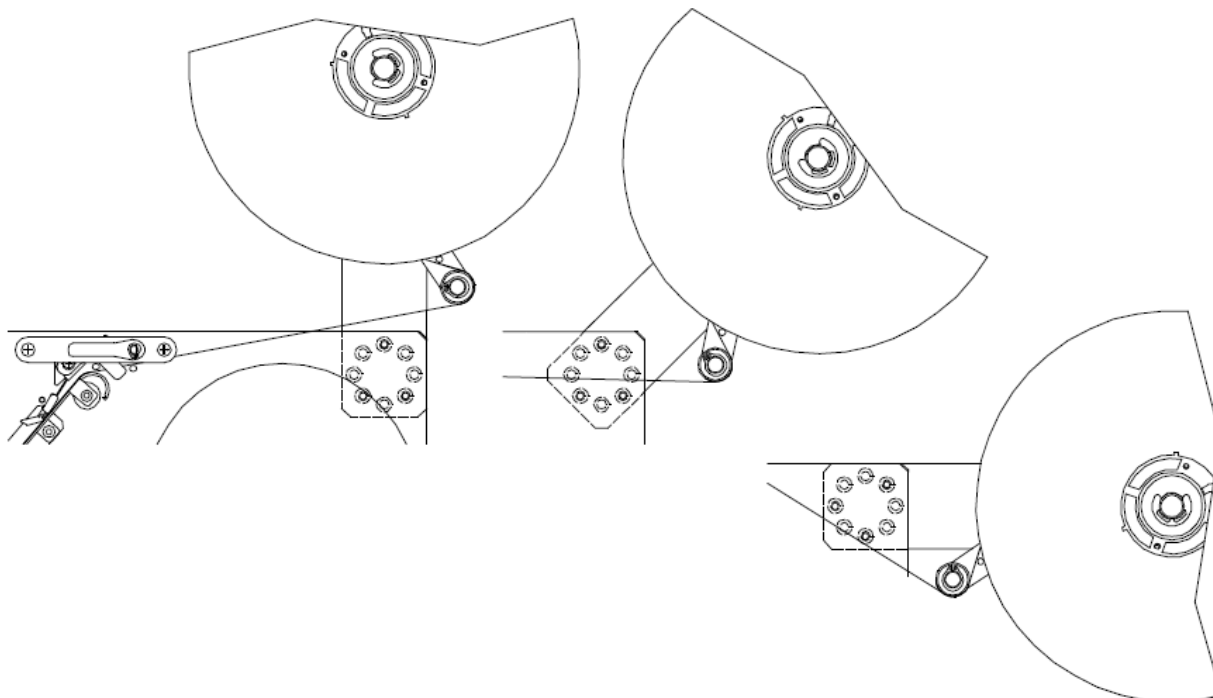

PICTURE 6

## 5.1. LABEL FORMAT SET UP PROCEDURE

(SEE PICTURES 4 and 5)

The printer retains the label length and the backing paper transparency in permanent memory.

**If changing label format or print media type** you have to use the following procedure to update the values:

- 1 - Switch the printer off.
- 2 - Lift the printing head up by rotating lever #25b. and 51b
- 3 - Thread the web between the printing roller and the printing head #21,105.
- 4 - Lift the pressure roller up by rotating lever #17b.
- 5 - Thread the web between the driving roller and the pressure roller #35,32 up to the rewinding shaft #15.
- 6 - Check web has been rightly positioned under the label photosensor #10.
- 7 - Lift the printing head and the pressure roller down by rotating levers #25a 51 a and #17a.
- 8 - Switch the printer on while pushing the print button.
- 9 - Printer ejects some labels (depending on their length) and stores the values of the media.
- 10 - Release the print button.
- 11 - The green led lit and the printer is ready to work.

## 6. PRINTING MEDIA DESCRIPTION

### 6.1. PAPER SPECIFICATIONS

White coated glossy printing paper

- weight: 65 ÷ 90 g/mq (ISO536)
- caliper: 0,075 ÷ 0,083 mm (ISO534)

ADHESIVE SPECIFICATIONS

- peel adhesion(90° C): 430 N/m
- service temperature: -20° C ÷ + 70° C

LINER SPECIFICATIONS

- BG 40 brown, supercalendered glassine
- weight: 65g/mq (ISO536)
- caliper: 0.057 mm (ISO534)
- transparency: 45%

SUGGESTED MODELS

- Fasson Fastransfer MP - S470
- Fasson Fastransfer Extra - S470

LABEL DIMENSIONS

See Chapter 2

### 6.2. THERMAL RIBBON SPECIFICATIONS

- film thickness 4.5 ÷ 6 micron
- core diameter: 25.4 mm
- width: 80 mm min/ 180 mm max
- length: about 600 meters
- ink coating outside

SUGGESTED MODELS

- TOIKO C 250 (matt paper)
- TOIKO CR 150 (glossy paper and polypropylene)
- TOIKO R 300 (plastic media)

STORAGE

Keep labels and ribbons in a dry place at temperature not over 40° C and not exposed to direct sun light.

## 7. THERMAL RIBBON AND LABEL ROLL REPLACEMENT

### 7.1. THERMAL RIBBON REPLACEMENT

(SEE PICTURE 7)

Remove the used roll. Remove the core #47 from the shaft and put it on the rewinder #29.

By rotating the levers #25b and 51b, lift the printing head #105 from the printing roller #21, setting the movement of the ribbon free.

Slide new ribbon #43 onto shaft and thread it under the ribbon photosensor #48 and the threaders #108 and 37 and up round to the rewinder #29.

Attach the ribbon leader with label/tape to core #47. Return head levers to closed position #25a and 51a.

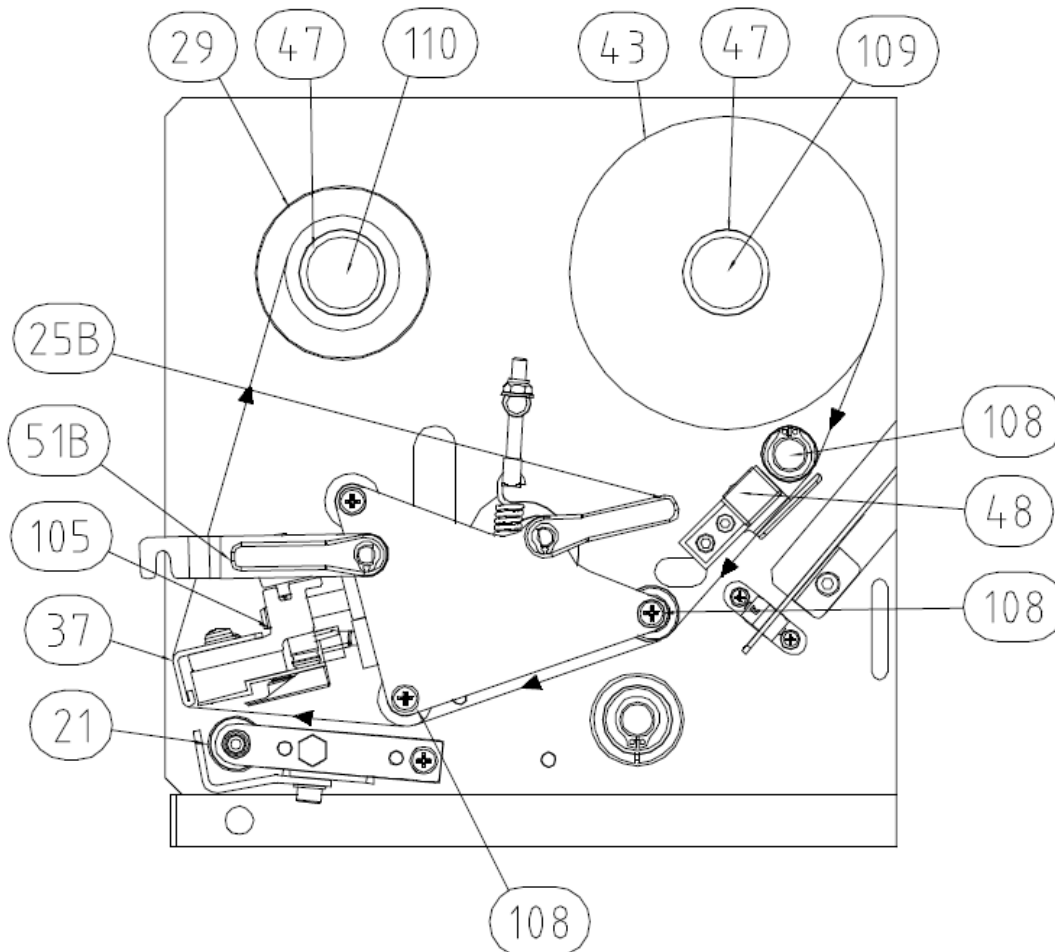

PICTURE 7

### 7.2. LABEL ROLL REPLACEMENT

(SEE PICTURE 5)

In case of changing of label format or printing media type, remember to follow the "Label format set up procedure" shown on paragraph 5.1.

Remove the movable flange by rotating the lever #41.

Remove the empty label roll.

Insert new label roll onto roller #45

Reassemble the movable flange and push it tightly against the side of the label roll; lock lever #41. labels and ribbon free.

Lift the printing head up by rotating lever #25b. and 51b

By rotating the lever #17b, lift the pressure roller #32 from the driving roller #35.

Remove clip #28 from the rewinding shaft #102.

Remove backing paper from the rewinding shaft.

Remove the first 50 centimetres from liner of the new roll labels.

Hold pressure clip #33b up and feed the liner through the path, thread the web between the printing roller and the thermal head #21,105, then around the driving roller and under the pressure roller #35,32, finally slide the liner on the rewinder unit #102 and fasten it with the clip holder #28.

Turn the rewinder to stretch the paper.

Turn head levers and toggle lever back to closed positions #25a, 51a, 17a.

Check paper has been rightly positioned under the movable label photosensor #10.

Release #33a and check pressure clip #33 has been positioned between centre and outer side of the label.

**WARNING: Italora OEM printer mechanisms must operate only in peel-off mode with backing paper rewound by toggle lever rollers. Any other print mode (strip form, tear-off, etc.) is not allowable and cause an incorrect paper feeding and bad printout quality.**

## 8. INTERFACING

### 8.1. SERIAL INTERFACE

Electronic Control Units 80.560.00xx for **AH 2006** printer mechanisms have a RS232 hardware interface (RS485 on request). Provided on board connector is a Cannon 25 pins "DB" female cabled as shown in the following pictures.

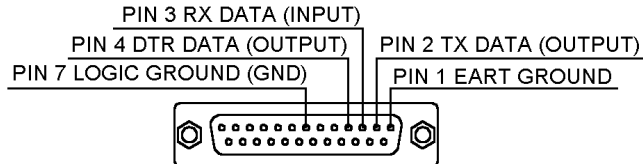

#### COMPUTER CONNECTOR WITH 9 PINS

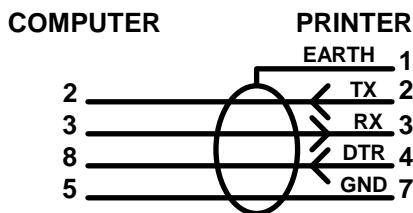

#### COMPUTER CONNECTOR:

- using sw protocol XON/XOFF:  
short together PINS 7-8 and 1-4-6.
- using hw protocol DTR:  
short together PINS 1-4-6.

#### COMPUTER CONNECTOR WITH 25 PIN

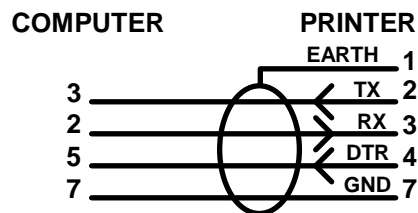

#### COMPUTER CONNECTOR:

- using sw protocol XON/XOFF:  
short together PINS 4-5 and 6-8-20.
- using hw protocol DTR:  
short together PINS 6-8-20.

### 8.2. I/O SIGNALS

Electronic Control Units 80.560.00xx are provided of three optoisolated lines for I/O signals: one input and two outputs. A six pins DIN connector type GPE/DIN 40040 is present cabled as follows.

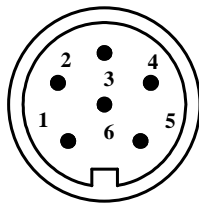

( FRONT EXTERNAL VIEW )

- 1) + START PRINT (INPUT)
- 2) - START PRINT (INPUT)
- 3) + ALLARM (OUTPUT)
- 4) - ALLARM (OUTPUT)
- 5) + PRINT END (OUTPUT)
- 6) - PRINT END (OUTPUT)

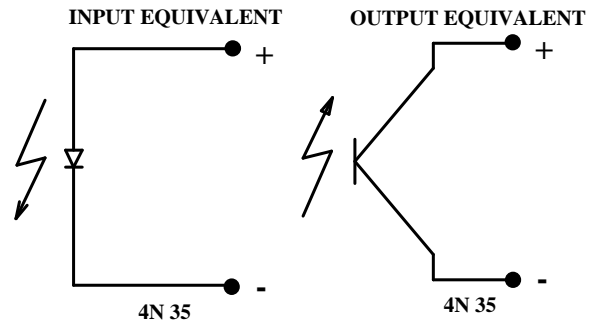

**PRINT END output** signal is a 250 milliseconds active pulse (optotransistor in conduction) when printer has finished to eject a printed label. This signal is commonly used to get one of ours printers interfaced with automatic systems, such as appliers. It can be programmed in two different ways with the "?66&" software command (see "**PROGRAMMING MANUAL**"):

\* "?66&0" standard behaviour: a pulse of 250 msec is driven as soon as the feeding of a label has been completed. In these 250 msec (optotransistor in conduction state) the signal goes from the high level (4.4V) to the low level (0.8 V).

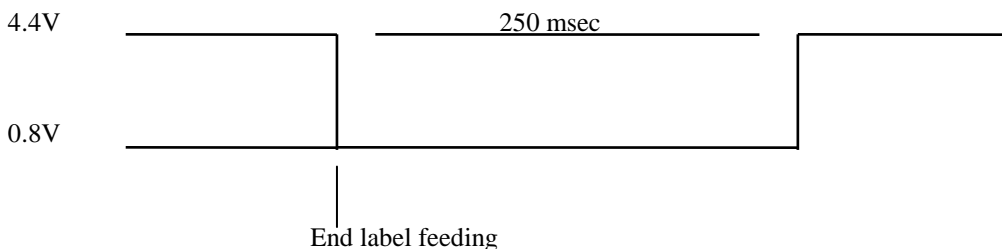

In this case the delay between a label and its next is, obviously, at least 250 msec.

\* “?66&I” : the pulse is driven (optotransistor in conduction state) during the whole label feeding so, in this period, the signal goes low.

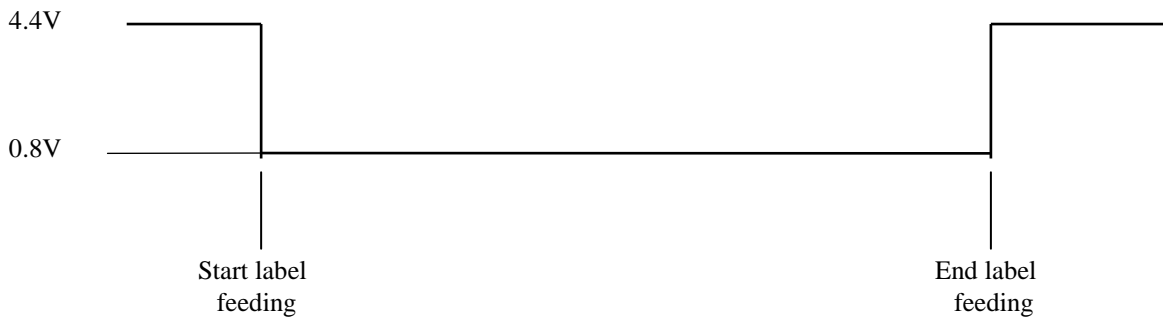

The electronic circuit is like this:

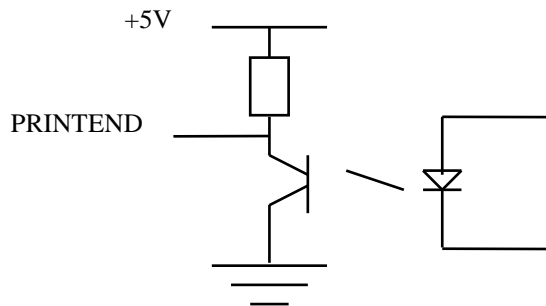

**ALARM output (OUTAUX)** signal is a level output becoming active (optotransistor in conduction) when printer detects an alarm condition: it remains active until alarm condition is present.

In end of paper or end of ribbon condition, together with the traditional led blinking, this auxiliary signal goes low and it stays there until you put the printer well again.

With your software you can program this signal in two different ways (see “**PROGRAMMING MANUAL**”):

\* *disabled signal* (default): the signal level is always high (4.4 V).

\* *enabled signal*: you can choose this possibility with the “?64&” software command; the signal goes low for the next 250 msec after the command decoding.

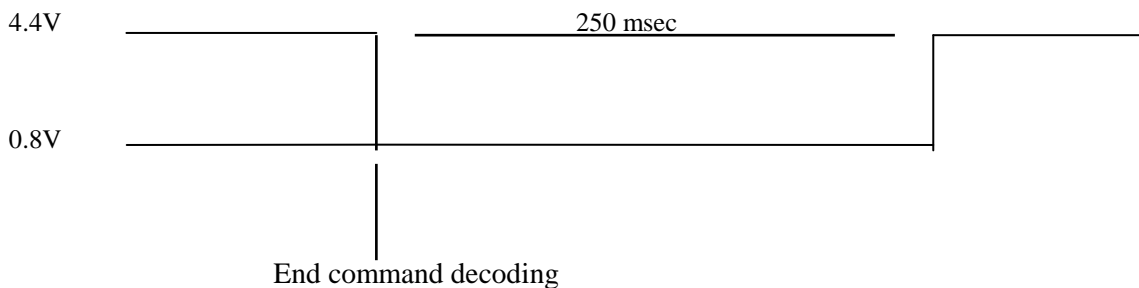

The electronic circuit is like this:

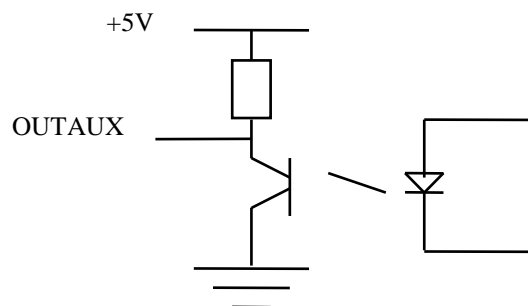

**START PRINT input** signal is activated by Set Up menu. For more information see “**PROGRAMMING MANUAL**”.

Meaning of START PRINT input is “print enable”: printer will not print any label, as after an Host computer command or as after a Print Button pushing, until START PRINT is active for at least 50 milliseconds. For every ejected label a 50 milliseconds minimum active pulse is required. Otherwise, after a pulse on this input, the printer will print only if a previous print or batch command was received, or a Print Button pushing was executed.

## 9. MAINTENANCE

WHEN NOT IN USE:

- SWITCH OFF POWER
- ALWAYS LIFT UP THE PRINTHEAD AND THE TOGGLE LEVER MECHANISM

## 9.1. CLEANING

### Print Head

- Turn the power off.
- Wait until thermal head cools down.
- Lift the print head by using the lever
- Remove labels and thermal ribbon.
- Moisten a cotton bud with isopropyl alcohol.
- Place it between thermal head and roller and move it gently from side to side.
- Repeat until clean.
- Slowly pull out cotton bud
- Wait until dry before use

**WARNING: never use hard tools as this may damage the print head.**

**Rubber feeding roll:** use alcoholic detergents.

**Photosensor:** use a soft brush.

**Metallic and plastic parts:** use a soft cloth with water-based detergent (weak).

**Removing adhesive traces or parts of labels:** use alcoholic detergents. Be careful the liquid does not drip on the electronic compartment.

## 10. TROUBLE SHOOTING

### 10.1. NO LABELS FEEDING

Four situations may occur.

a) RED led is OFF, check (pict.1,#100):

- main voltage
- main switch (pict.1,#103) ON.
- main connector (pict.1,#104) plugged in
- main fuses (pict.1,#6) intact.

b) RED led is ON, STATUS led is BLINKING GREEN, check:

- label roll is not used up.
- paper position under the photosensor (pict.5,#10)

c) RED led is ON, STATUS led is BLINKING alternately GREEN and YELLOW, check:

- thermal ribbon is not used up.
- thermal ribbon position under the photosensor (pict.5,#48).

d) RED led is ON, STATUS led is BLINKING YELLOW:

- head temperature control active, printer stops until temperature has fallen to normal values.

### 10.2. INCORRECT LABEL ALIGNMENT

Make sure that:

- print head is closed (pict.5,#25a)
- toggle lever is closed (pict.5,#17a)
- paper position under the photosensor (pict.5,#10)
- backing paper is correctly rewound (pict.5,#102)
- pressure clip (pict.5,#33) is positioned

between centre and outer side of the label.

- movable flange is tightly pushed against the side of the label roll with the lever (pic.5,#41) in lock position.

See also "Label format set up procedure" paragraph 5.1

### 10.3. PAPER SLIDES TO RIGHT SIDE

Check whether:

- pressure clip (pict.5,#33) is positioned between centre and outer side of the label.

- movable flange is closely positioned against the side of the label roll with the lever (pic.5,#41) in lock position.

### 10.4. PRINTING WITH PATCHES MISSING

Check whether:

- thermal print head needs cleaning (chapter 9)
- thermal ribbon unwinds correctly.

- there are creases on the rewound thermal ribbon. If so, turn the nut (pict.7,#110) clockwise, in order to increase the rewinding torque (a quarter of a turn max) while holding the roller (pict.7,#29) still.

### 10.5. BLANK LABELS

Check whether

- the fuse (8AT) on the back panel has blown
- the print head connector is correctly plugged in

(pict.4,#112) with polarity key up.

- thermal ribbon is correctly positioned, opaque surface on the label side.

### 10.6. POOR PRINTING CONTRAST

- See Electronic Control Unit rear panel.
- turn the print head screw (pict.1,#106) for temperature fine adjustment : clockwise to make print darker.

anticlockwise to make print lighter.

Otherwise use the software command ?77& (see Programming Manual)

**BEWARE:** continual high operating temperature of thermal head may reduce its working life and may also fuse the ribbon.

## 11. HARDWARE NOTES

### 11.1. HOW TO CHECK ELECTRONIC BOARDS

- First unplug the power cable from the electronic cabinet.
- turn the 4 front and the 4 rear screws out (pict.8a#114 - 121).
- remove front and rear panels.
- turn the 4 side screws out (pict.8a,#122 - 125).
- turn the 3 inner screws out (pict.8b,#126 - 128).
- Unplug the following connectors from CPU board (pict.21).and pull carefully off the electronic boards from the chassis

Y2 = ribbon photosensor

Y3 = leds and push button

Y4 = stepping motor

Y5 = label photosensor

Y7 = serial interface

Y10 = power supply

Y14 = fan

Y15 e YGM = thermal head

- disconnect the ground cable turning the chassis nut out

- unplug the fuses connectors and the main switch connector.

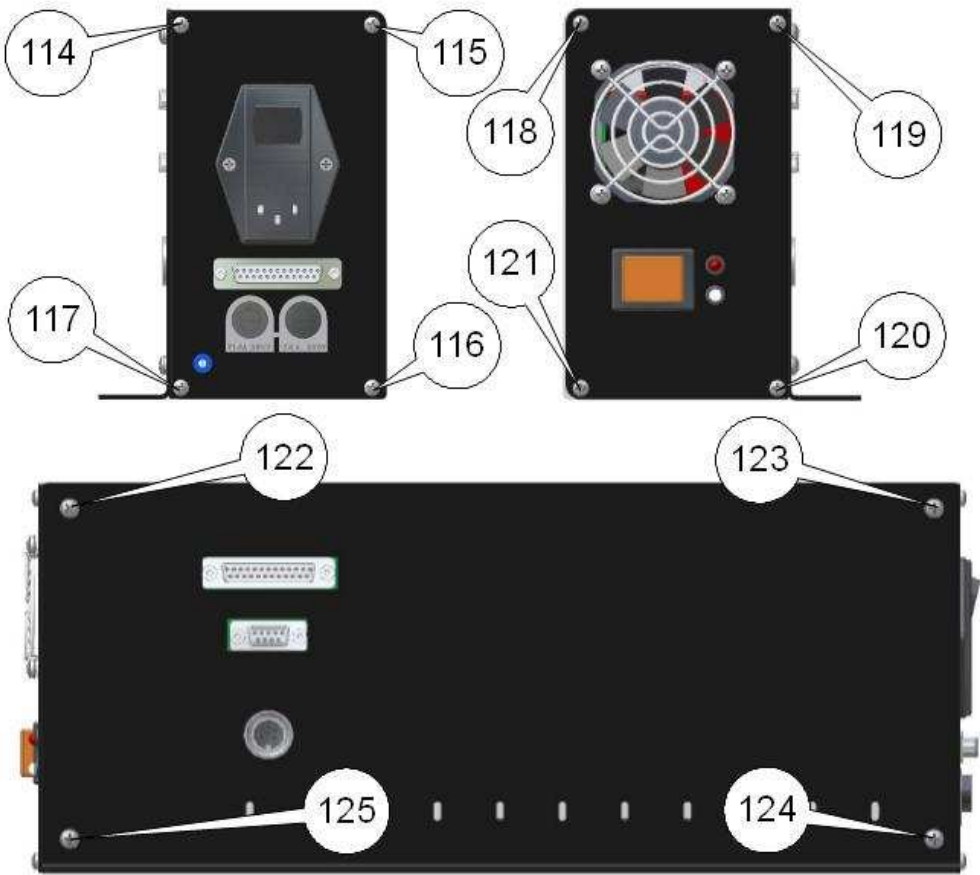

PICTURE 8a

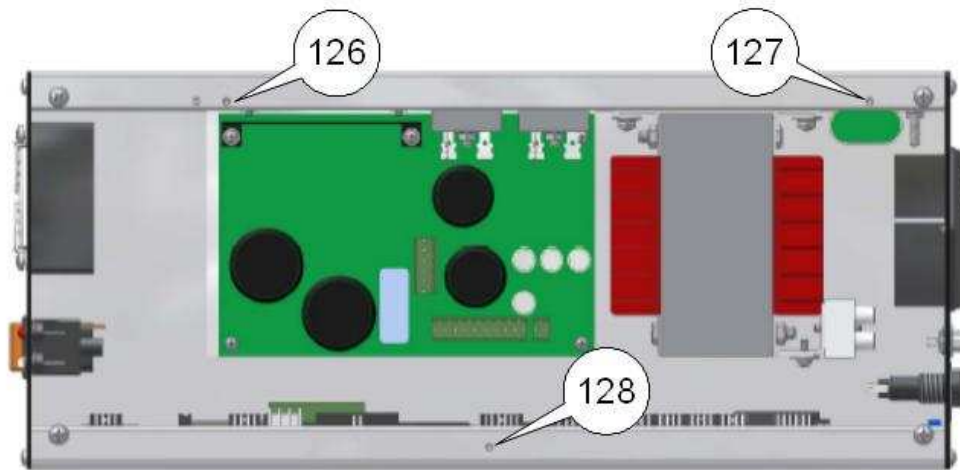

PICTURE 8b

## 11.2. PRINT HEAD PROTECTION FUSE REPLACEMENT

- Thermal print head is protected by an 8 A timed fuse (pict.1,#9).

## 11.3. THERMAL PRINT HEAD REPLACEMENT

(SEE PICTURE 9)

- 1 switch the printer off .
- 2 unplug connectors #112 from the print head.
- 3 lift print head by rotating the levers #25c and 51b..
- 4 turn the screw #130 out.
- 5 remove the adjusting nut #18.
- 6 pull out the print head and dissipater assembly from the pivot pin.
- 7 turn the screw #138 out and remove the print head #26 from the dissipater.
- 8 replace thermal head and run back steps 7 to 2.

**WARNING: pay attention to plug in correctly thermal head connector(s), wrong connection causes**

**irreversible damage to the print head functionality (pict. 4)**

- 9 in case of printing quality problems, loosen the screw #130 and turn slowly the adjusting nut in or out #18, for the best printing quality, finally lock the screw #130.
- 10 in case of creases on the rewind thermal ribbon, loosen the screws #128,129 and adjust the plate #37 in order to obtain a correct parallelism and flatness on the rewind ribbon; finally lock the screws #128,129.

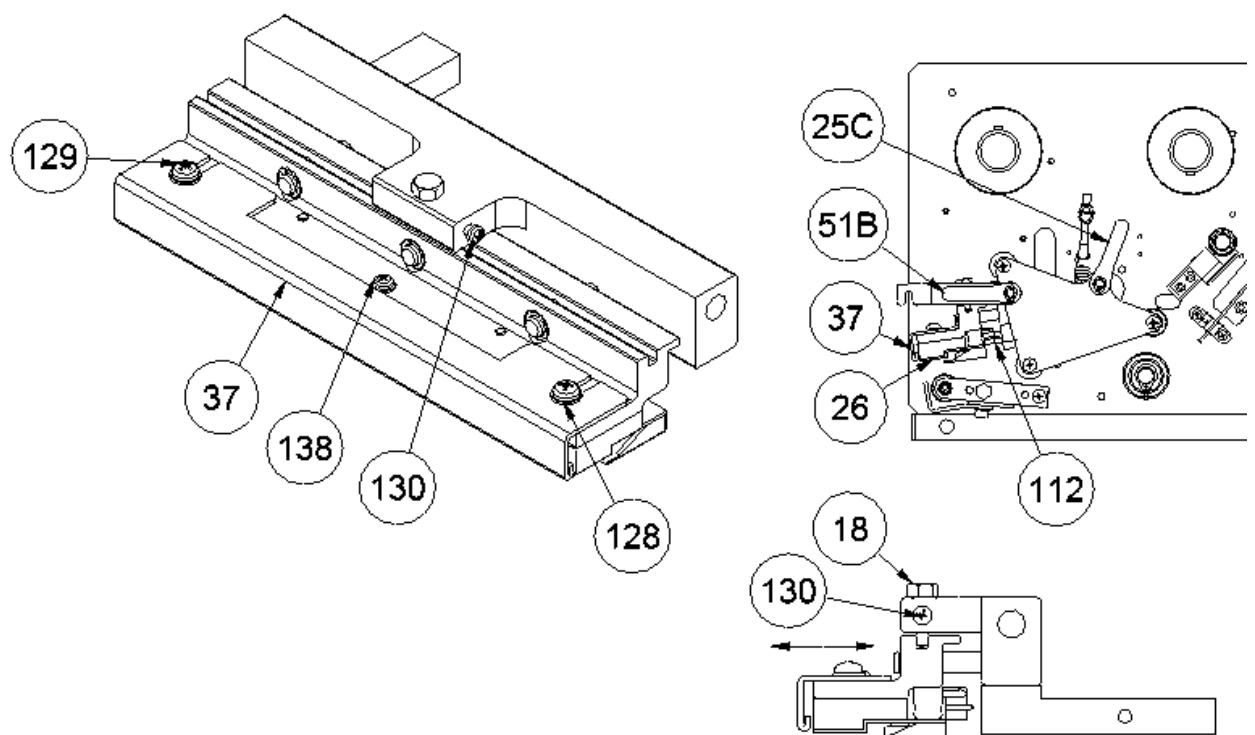

PICTURE 9

#### 11.4. DRIVE BELT REPLACEMENT (SEE PICTURE 10)

Remove the connection board and the safeguard plate from the spine, then loosen the relevant idler #16 and remove the belt. Replace the relevant belt and stretch

it by the idler till you get a deflection of 4 to 6 mm when applying a force of 7 N. Reassemble the safeguard plate and the connection board.

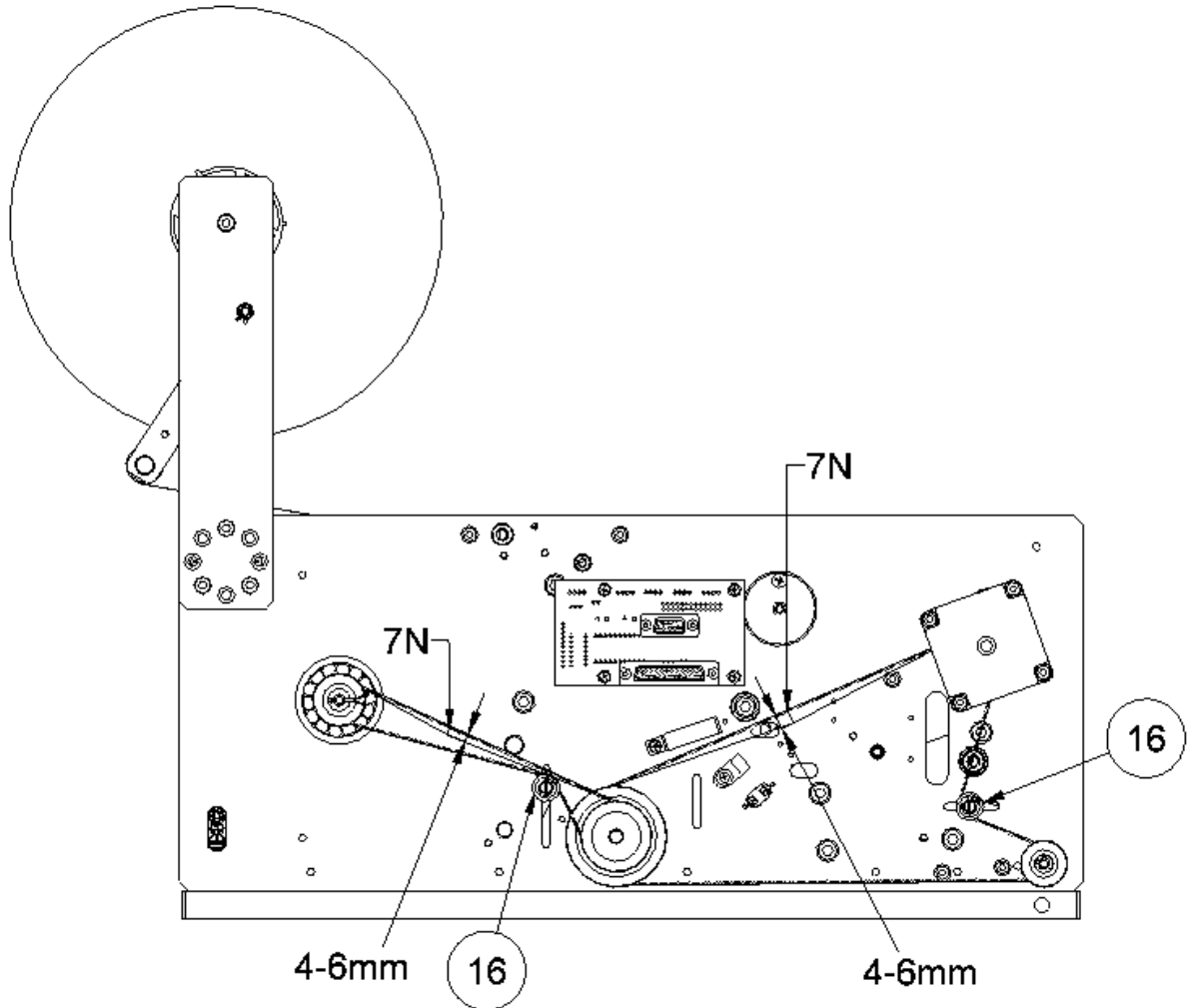

PICTURE 10

## 12. SCHEMES

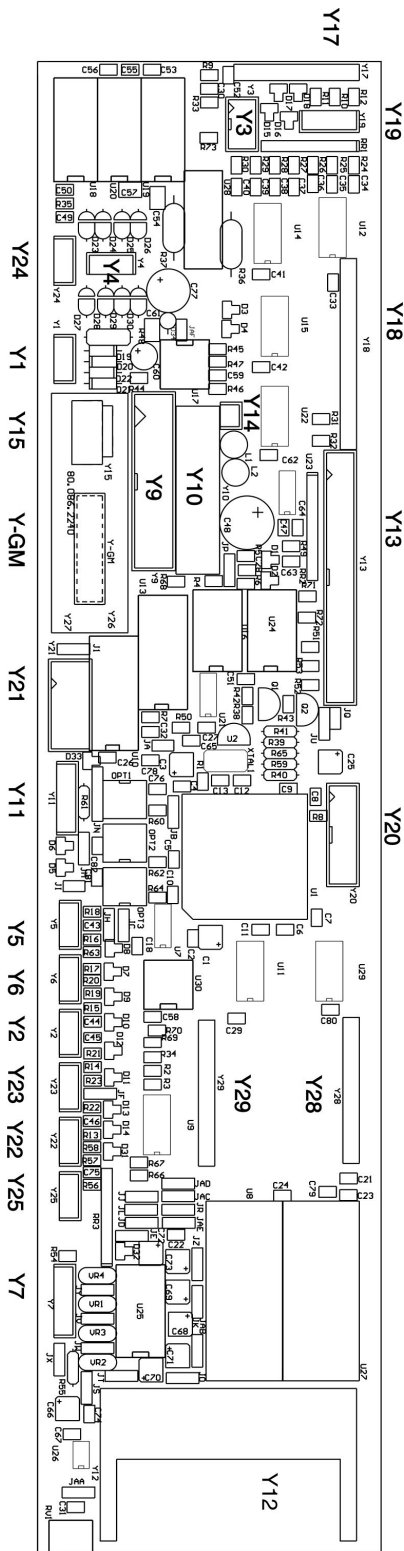

- Y1
- Y2     Ribbon sensor
- Y3     Push button, Leds
- Y4     Motor
- Y5     Label sensor
- Y6     Label taken sensor
- Y7     Serial port
- Y8
- Y9
- Y10    Power supply
- Y11    Optocouplers
- Y12
- Y13
- Y14    Fan
- Y15    Thermal head (power)
- YGM    Thermal head (signals)
- Y16
- Y17
- Y18
- Y19
- Y20
- Y21
- Y22
- Y23

PICTURE 21

LOGIC BOARD - layout



### 13. PART LIST AND RELEVANT PICTURES

(items are referred to following pictures)

ITEM	CODE	DESCRIPTION	AH 2006
1	055002101	push button	*
2	801665280	DIN connector assy	*
3	800925280	ring clip	*
4	801292050	filter cap	*
5	056102080	fuse 2A T	*
6	056102020	fuse 1.6A T	*
7	801292090	fuse holder	*
8	801665050	RS232 connector	*
9	056102030	fuse 8A T	*
10	809065080	label photosensor assy	*
11	801665250	leds assy	*
12	059006010	cable 25 pins, 1000 mm	*
13	800945H3002	power board	*
14	059006020	cable 9 pins, 1000 mm	*
15	80087510272	logic board GM	*
16	800925310	belt idler assy	*
17	800762090	lever	*
18	800722460	nut	*
19	061702050	bushing	*
20	800928524	connection board GM (printer)	*
21	800927730	printing roller	*
22	801800104	rewinding pulley assy	*
23	800742100	spring	*
24	800927740	peeling plate assy	*
25	800927800	lever cam	*
26	800822780	thermal print head (8 dot GM)	*
27	800925290	knob	*
28	801842130	clip holder	*
29	800927760	ribbon rewinding assy	*
30	800945750	ribbon stock assy	*
31	800925330	connection board GM (electronic cabinet)	*
33	810940029	media position holder assembly	*
34	800782180	belt	*
35	800945770	driving roller assy	*
36	800782080	belt	*
37	800542760	ribbon plate	*
38	800502271	side panel	*
39	801622160	ribbon rewinding gear	*
40	800926220	fan assy 60 x 60 mm	*
41	801605260	fixed flange assy	*
42	051507490	print head flat cable	*
44	061702060	bushing	*
45	800927850	label unwind holder	*
46	801605200	movable flange assy	*
47	800927780	heat dissipater assy	*
48	801625030	ribbon photosensor	*
49	800945800	stepper motor assy	*
50	801842501	tie rod	*
51	800762080	lever	*

